

GENUINE MOTOR PARTS & ACCESSORIES



2015

DYNA®

As a direct descendant of the original "factory custom" motorcycles, the Dyna® family delivers the purest kind of inspiration. No boundaries. No expectations. No rules. And nowhere to go but to the limits of your imagination.



DYNA





DYNA®

STREET BOB®

FXDB | PRODUCTION COLOR: AMBER WHISKEY

Narrow satin black Chizeled handlebar*. Small Bullet headlamp. Jet black Screamin' Eagle® Street Performance mufflers. Brushed nickel Silencer controls. Distressed leather and brass bobber solo saddle. Can you say "bad-ass"? This Street Bob® motorcycle has everything you need to make a big, bold statement. And nothing that you don't.



SEE WHAT'S ON THIS BIKE AT [H-D.COM/GALLERY](https://www.harley-davidson.com/gallery)

*Handlebar height is regulated in many areas. Check local laws before installing.





DYNA®

LOW RIDER®

FXDL | PRODUCTION COLOR: DEEP JADE PEARL

Deep Jade paint and the perfect balance of black and chrome transform the look of this elegant Low Rider® model. The gloss black front end, Chisel air cleaner, and jet black Nightstick exhaust complement the bike's factory black and silver detailing, and the adjustable handlebar and removable seat pad accommodate a wide range of rider sizes.





DYNA®

FAT BOB®

FXDF | PRODUCTION COLOR: MYSTERIOUS RED SUNGLO

No question, this Fat Bob® motorcycle was born to brawl. Its Dark Custom™ soul runs deep – from the gloss black fender struts and brake rotors to the Ventilator Elite air cleaner cover and Screamin' Eagle® exhaust. And the hard-hitting machined highlights of the Black Fin engine trim and Burst Collection foot controls make a big visual impact.





DYNA®

WIDE GLIDE®

FXDWG | PRODUCTION COLOR: BLACK QUARTZ WITH FLAMES

A Wide Glide® motorcycle just wouldn't be the same without flames and chrome. It starts with the flamed Black Quartz tank and runs all the way down to the Flame Collection footpegs, shifter peg, and brake pedal. The chrome Bullet headlamp and Street Slammer Bar keep things lean, while the chrome Thunderstar™ wheels keep the heat set on high.





DYNA®

SWITCHBACK™

FLD | PRODUCTION COLOR: VIVID BLACK

Presenting a true touring powerhouse. Outfitted with a narrow beach bar, Rallyrunner® seat and passenger backrest, this machine is ready to rack up the miles. And while all that chrome brightens up the day, you're ready to fight back the night with Daymaker™ Reflector LED headlamps, auxiliary lamps, and fog lamps to light the way.



SEE WHAT'S ON THIS BIKE AT [H-D.COM/GALLERY](https://www.harley-davidson.com/gallery)

LOW RIDER® TRANSFORMATION

The latest in a long line of customs, the Low Rider® model honors its legendary heritage with black-highlighted accents, a '70s inspired seat, and unmistakable sculpted 2-into-1 exhaust.

HIGH STYLE

Of course, true lovers of the Low Rider® model legend will still want to make it something to call their own. It starts with a dark and seductive Black Magic paint that plays off the abundant chrome highlights—from the short sissy bar to the Teardrop floating brake rotors—for a shine that just

can't be missed. The Daymaker™ LED headlamp and LED turn signals and tail lamp make sure you draw needed attention at night, and the lightly smoked Quick Release Compact Windshield will cut through the breeze, but comes off in seconds when you'd rather feel the wind in your face.



SHORT PASSENGER
BACKREST

LED TAIL LAMP
& TURN SIGNALS

CHROME SWINGARM
& AXLE COVERS

SCREAMIN' EAGLE®
NIGHTSTICK MUFFLERS



FIT

Parts list available at h-d.com/gallery

Featuring a unique handlebar riser that provides 2.4" of adjustment and an innovative seat design that allows 1.5" of fore-aft movement, the Low Rider® model will fit almost any rider. Sit down, grab ahold, and take off.

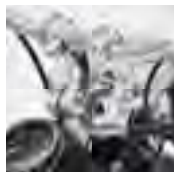

FUNCTION

So what if Sturgis is 1,200 miles away. With a detachable windshield, a backrest, and some soft touring luggage on the passenger pillion, this Low Rider® model is ready to comfortably chew up the miles. And when you get there, strip off the gear and hit the town.



STYLE

Dipped in chrome, this fully loaded Low Rider® model grabs your attention and doesn't let go. From the chrome hand controls and engine trim to the chrome swingarm and layback license plate, this bike is the definition of the long and lean look.



PERFORMANCE

The low profile Screamin' Eagle® Ventilator exposed element air cleaner provides increased airflow to boost the power, and the 2-into-1 Screamin' Eagle® Nightstick muffler provides the deep-throated rumble we are famous for.





 CARE AND MAINTENANCE

While it's tempting to use standard "auto parts store" cleaning and service supplies, hold out for the real thing. Genuine Harley-Davidson® coolant, oils, filters, batteries and service parts are engineered for the unique surfaces and operating conditions your Harley® motorcycle will encounter.



DAYMAKER™ LED HEADLAMP



SCREAMIN' EAGLE® VENTILATOR AIR CLEANER

 CRAFTSMANSHIP

We design and build the bikes, so we don't need to "reverse-engineer" parts to try and make them fit. Everything we make is rigorously tested to ensure it meets our high standards, and the finishes of our accessories match the bike's surfaces for a consistent appearance.



LED TAIL LAMP & TURN SIGNALS



QUICK RELEASE COMPACT WINDSHIELD

142 DYNA®

Windshields

A. QUICK-RELEASE SUPER SPORT WINDSHIELD

Reduces the pounding of wind and shower of bugs, but keeps the wind-in-the-hair feeling. Ideal for a cool morning ride, the sleek profile of the Super Sport Windshield hugs the front headlamp for a sporty look. The windshield mounts to the fork tubes with elegant die-cast lever locking clamps, so the windshield does not require any "leave-behind" docking hardware. You get quick on-and-off convenience and a clean, custom look. No tools are required and the kit includes everything needed to install the windshield.

57300-06 19" Light Smoke. **\$349.95**
Fits '06-later Dyna® models (except FLD, FXDWG, FXDF and FXDSE). Windshield dimensions: Overall height – 25.0"; width – 20.1".

57301-06 19" Light Smoke. **\$349.95**
Fits '06-later FXDWG and '13-later FXSB and FXSBSE models. Windshield dimensions: Overall height – 25.0"; width – 20.1".

57331-07 16" Light Smoke. **\$359.95**
Fits '07-'08 FXDSE and '00-later FXST, FXSTB and FXSTC models equipped with Custom Inverted Front Fork Kit P/N 46321-05, 46321-05A or 48646-06. Windshield dimensions: Overall height – 22.1"; width – 15.3".

57838-08 19" Light Smoke. **\$324.95**
Fits '88-later XL (except XL1200T, XL1200X, '11-later XL883L and XL1200C) and '91-'05 Dyna models (except FXDWG and FXDXT). XL Custom models require Front Directional Relocation Kit P/N 68517-94A. Windshield dimensions: Overall height – 25.0"; width – 20.1".

B. H-D® DETACHABLES™ SUPER SPORT WINDSHIELD

Super is an apt description for this do-it-all windshield with detachable convenience and sport styling. The windshield mounts to the fork tubes with H-D® Detachables™ Docking Hardware (sold separately) for easy on-and-off convenience and a quick return to a sporting profile.

57965-97A 18" Light Smoke. **\$229.95**
Fits '84-later FXST, FXSTC, FXSTB, '93-'05 FXDWG, '80-'86 FXWG. (Does not fit FXSTD.) Use Docking Hardware Kit P/N 58350-96. Windshield dimensions: Overall height – 22.3"; width – 17.8".

Shown with:

DOCKING HARDWARE FOR H-D DETACHABLES WINDSHIELDS

58164-96A For 39mm Forks. **\$79.95**
Required for installation of H-D Detachables Windshields on '88-later XL (except XL1200X, '11-later XL883L and XL1200C) and '91-'05 Dyna models (except FXDWG and FXDXT). XL and Dyna models with Front Turn Signals originally located on the upper triple clamp may require the additional purchase of Turn Signal Wiring Kit P/N 72389-96.

58350-96 For 41mm Forks. **\$79.95**
Required for installation of H-D Detachables Windshields on '84-later FXST, FXSTC, FXSTB, '93-'05 FXDWG, '80-'86 FXWG models. (Does not fit FXSTD.)

C. SPORT WINDSHIELD KIT

Formed of polycarbonate and hard-coated to resist scratching. Light smoke windshield is contoured to fit the headlamp and incorporates adjustable four-point mounting. Functional styling helps deflect wind to reduce upper body fatigue.

58192-87A 18" Light Smoke. **\$164.95**
Fits '88-later XL (except XL Custom, XL1200T, XL1200X and '11-later XL883L) and '95-'05 Dyna models (except FXDWG and FXDXT). Includes black mounting hardware. Windshield dimensions: Overall height – 18.5"; width – 16.3".

91820-85A 18" Light Smoke. **\$164.95**
Fits '84-later FXST, FXSTB, FXSTC, '93-'05 FXDWG and '86-earlier FXWG models. Windshield dimensions: Overall height – 20.0"; width – 15.0".

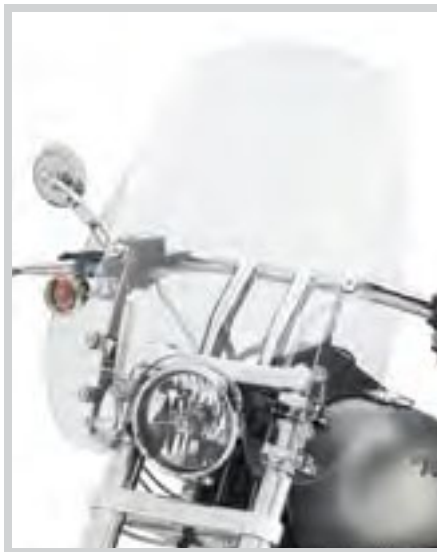

A. QUICK-RELEASE SUPER SPORT WINDSHIELD (57300-06 SHOWN)



A. QUICK-RELEASE SUPER SPORT WINDSHIELD (57838-08 SHOWN)



A. QUICK-RELEASE SUPER SPORT WINDSHIELD (57331-07 SHOWN)



A. QUICK-RELEASE SUPER SPORT WINDSHIELD (57838-08 SHOWN)



B. H-D DETACHABLES SUPER SPORT WINDSHIELD



C. SPORT WINDSHIELD KIT (58192-87A SHOWN)

DYNA® 143

Windshields

D. QUICK-RELEASE COMPACT WINDSHIELD

Combine the classic Harley-Davidson® windshield shape with a revolutionary new attachment system and you have the best of style and function. The windshield mounts to the fork tubes with elegant die-cast lever-release clamps, so the windshield does not require any "leave-behind" docking hardware. You get quick on-and-off convenience and a clean, custom look. No tools are required and the kit includes everything needed to install the windshield. The tough, hard-coated polycarbonate windshield is available in your choice of traditional polished or gloss black horizontal and vertical braces.

Fits '06-later Dyna® models (except FLD, FXDWG, FXDF and FXDSE).

58346-06 18" Clear – Polished Braces. **\$369.95**

Windshield dimensions: Overall height – 26.8"; width – 19.7".

58347-06 18" Light Smoke – Polished Braces. **\$389.95**

Windshield dimensions: Overall height – 26.8"; width – 19.7".

58348-06 14" Light Smoke – Polished Braces. **\$384.95**

Windshield dimensions: Overall height – 22.8"; width – 19.5".

Fits '06-later FXDWG and '13-later FXSB and FXSBSE models.

58387-06 18" Clear – Polished Braces. **\$369.95**

Windshield dimensions: Overall height – 26.8"; width – 19.5".

58413-06 18" Light Smoke – Polished Braces. **\$389.95**

Windshield dimensions: Overall height – 26.8"; width – 19.5".

58444-06 14" Light Smoke – Polished Braces. **\$389.95**

Windshield dimensions: Overall height – 22.8"; width – 19.5".

Fits '08-later FXDF and FXDFSE models.

57338-08 19" Clear – Polished Braces. **\$369.95**

Windshield dimensions: Overall height – 27.0"; width – 19.6".

58617-09 19" Clear – Black Braces. **\$389.95**

Windshield dimensions: Overall height – 27.0"; width – 19.6".

57340-08 15" Light Smoke – Polished Braces. **\$389.95**

Windshield dimensions: Overall height – 23.0"; width – 19.6".

58630-09 15" Light Smoke – Black Braces. **\$409.95**

Windshield dimensions: Overall height – 23.0"; width – 19.6".

Fits '88-later XL (except XL1200T, XL1200X, '11-later XL883L and XL1200C) and '91-'05 Dyna models (except FXDWG and FXDXT).

58063-04 18" Clear – Polished Braces. **\$369.95**

Windshield dimensions: Overall height – 26.8"; width – 19.7".

58706-09 18" Clear – Black Braces. **\$389.95**

Windshield dimensions: Overall height – 26.8"; width – 19.7".

58601-04 18" Light Smoke – Polished Braces. **\$399.95**

Windshield dimensions: Overall height – 26.8"; width – 19.7".

58602-04 14" Light Smoke – Polished Braces. **\$389.95**

Windshield dimensions: Overall height – 22.8"; width – 19.5".

58703-09 14" Light Smoke – Black Braces. **\$419.95**

Windshield dimensions: Overall height – 22.8"; width – 19.5".

Fits '93-'05 FXDWG and '86-later FXST, FXSTC and FXSTB models.

59802-05 19" Clear – Polished Braces. **\$429.95**

Windshield dimensions: Overall height – 23.8"; width – 21.4".

58360-09 19" Clear – Black Braces. **\$459.95**

Windshield dimensions: Overall height – 23.8"; width – 21.4".

58751-05 19" Light Smoke – Polished Braces. **\$449.95**

Windshield dimensions: Overall height – 23.8"; width – 21.4".

57199-05 16" Light Smoke – Polished Braces. **\$439.95**

Windshield dimensions: Overall height – 20.8"; width – 21.4".

58376-09 16" Light Smoke – Black Braces. **\$469.95**

Windshield dimensions: Overall height – 20.8"; width – 21.4".

Also available:

TURN SIGNAL RELOCATION KIT

Styled to blend with the lower triple clamp. This chrome-plated Turn Signal Relocation Kit moves the Original Equipment bullet-style turn signals from the handlebar to the front fork for a clean, streamlined look. Kit includes left and right mounting stalk and all required hardware.

69433-08A **\$89.95**

Fits '08-later Dyna models (except FLD and FXDSE/2).



D. QUICK-RELEASE COMPACT WINDSHIELD – POLISHED BRACES



D. QUICK-RELEASE COMPACT WINDSHIELD – 15", GLOSS BLACK BRACES (SHOWN WITH TURN SIGNAL RELOCATION KIT)

DYNA

Notice: The prices appearing in this catalog are the manufacturer's suggested retail prices. Actual retail prices may vary.

144 DYNA®

Windshields

A. H-D® DETACHABLES™ TALL WINDSHIELD – SWITCHBACK™

Get maximum protection from the wind. The detachable shield can be removed and reinstalled in seconds to tailor your bike to different riding conditions.

57400120 20" Clear. **\$349.95**

Fits '12-later FLD models. Windshield dimensions: Overall height – 27.0"; width – 24.0".

B. H-D DETACHABLES COMPACT WINDSHIELD FOR MODELS WITH AUXILIARY LIGHTING

Whether it's for keeping bugs off your face or warmth in your body, a windshield has a huge impact on rider and passenger comfort. By diverting air pressure past your chest and over your helmet, a windshield can add hours of riding comfort. This high-quality polycarbonate windshield mounts to the fork tubes with detachable Docking Hardware for easy on-and-off convenience and a quick return to a stripped-down profile and is shaped to fit models equipped with Auxiliary Lighting Kits.

57609-08 18" Clear. **\$389.95**

Fits '06-later Dyna® models (except FLD, FXDWG, FXDSE, FXDF and '14-later FXDL) equipped with Auxiliary Lighting Kits. Includes Quick-Release Docking Hardware. Windshield dimensions: Overall height – 26.8"; width – 19.7".

57716-01 18" Clear. **\$289.95**

Fits '88-later XL (except XL1200T, XL1200X, '11-later XL883L and XL1200C) and '91-'05 Dyna models (except FXDWG and FXDXT) equipped with Auxiliary Lighting Kits. Requires the separate purchase of Docking Hardware Kit P/N 58164-96A and Turn Signal Relocation Kit P/N 68603-01. Windshield dimensions: Overall height – 26.8"; width – 19.7".

58865-03 18" Clear. **\$299.95**

Fits '93-'05 FXDWG and '84-later FXST, FXSTC, FXSTB models equipped with Auxiliary Lighting Kits. Requires separate purchase of Docking Hardware Kit P/N 58361-03. Windshield dimensions: Overall height – 21.9"; width – 21.4".

Also available:

TURN SIGNAL RELOCATION KIT

This kit relocates the turn signals to the passing lamp bracket and allows the use of a detachable windshield. Kit includes all necessary hardware required for installation.

68603-01 **\$49.95**

Fits '88-later XL (except XL1200T), '91-'05 Dyna and '84-later FXS, FXST, FXSTC and FXSTB Softail® models equipped with Auxiliary Lighting Kits.

Also available:

WINDSHIELD DOCKING HARDWARE AND TURN SIGNAL RELOCATION KIT

Required for installation of H-D® Detachables™ Windshields on FXDWG and FXST models equipped with Auxiliary Lighting Kits. Includes windshield mounting hardware and turn signal relocation hardware.

58361-03 **\$89.95**

Fits '93-'05 FXDWG and '84-later FXST, FXSTC, FXSTB models equipped with Auxiliary Lighting Kits.

Also available:

TURN SIGNAL RELOCATION KIT

Styled to blend with the lower triple clamp. This chrome-plated Turn Signal Relocation Kit moves the Original Equipment bullet-style turn signals from the handlebar to the front fork for a clean, streamlined look. Kit includes left and right mounting stalk and all required hardware.

58742-05 **\$59.95**

Fits '93-'05 FXDWG, '86-later FXST, FXSTC, FXSTB and '00-'07 FXSTD models.



A. H-D DETACHABLES TALL WINDSHIELD – SWITCHBACK



B. H-D DETACHABLES COMPACT WINDSHIELD FOR MODELS WITH AUXILIARY LIGHTING

Notice: The prices appearing in this catalog are the manufacturer's suggested retail prices. Actual retail prices may vary.



C. VENTILATOR QUICK-RELEASE COMPACT WINDSHIELD

C. VENTILATOR QUICK-RELEASE COMPACT WINDSHIELD

In a nutshell, a windshield should provide a barrier between the rider and errant bugs, discarded cigarette butts, flying debris and bad air. The shield should manage airflow and wind blasts to create a pocket of still air for both rider and passenger comfort. But if you ride in a warm climate or spend time at low speeds stuck in traffic, you need to keep some air circulating around your body to stay comfortable. The Ventilator Windshield features clear injection-molded vents that allow you to adjust the airflow to match the riding conditions. Opening the vents redirects the air across your chest for a cooling effect and closing the vents provides maximum wind and weather protection. But when you want to ride "naked," the detachable shield can be removed completely and reinstalled in seconds to match your riding mood.

57400025 19" Clear. **\$429.95**
 Fits '88-later XL (except XL1200T, XL1200X, '11-later XL883L and XL1200C) and '91-'05 Dyna® models (except FXDWG and FXDXT). Windshield dimensions: Overall height – 28.0"; Overall width – 21.4".

57400026 19" Clear. **\$429.95**
 Fits '06-later Dyna models (except FLD, FXDF, FXDWG and FXDSE). Windshield dimensions: Overall height – 28.0"; Overall width – 21.4".

57400028 20" Clear. **\$479.95**
 Fits '93-'05 FXDWG and '86-later FXST, FXSTC and FXSTB models. Windshield dimensions: Overall height – 24.8"; Overall width – 21.3".

D. QUICK-RELEASE TOURING WINDSHIELD

The Touring Windshield features an aerodynamic design shaped to provide hours of riding comfort. The additional center width directs airflow past the hand grips and deflects rain and road debris around the rider. The windshield mounts to the fork tubes with elegant die-cast lever-release clamps, so the windshield does not require any "leave-behind" docking hardware. You get quick on-and-off convenience and a clean, custom look. No tools are required and the kit includes everything needed to install the windshield. The tough, hard-coated polycarbonate windshield features traditional polished horizontal and vertical braces.

Fits '06-later Dyna models (except FLD, FXDF, FXDWG and FXDSE). Windshield dimensions: Overall height – 26.3"; width – 25.0".

57015-06 19" Clear. **\$439.95**

57016-06 19" Light Smoke. **\$459.95**

Fits '88-later XL (except XL1200T, XL1200X, '11-later XL883L and XL1200C) and '91-'05 Dyna models (except FXDWG and FXDXT). Windshield dimensions: Overall height – 28.3"; width – 22.1".

58158-08 19" Clear. **\$439.95**



D. QUICK-RELEASE TOURING WINDSHIELD – LIGHT SMOKE

Notice: The prices appearing in this catalog are the manufacturer's suggested retail prices. Actual retail prices may vary.

146 DYNA®

Windshields

A. WINDSHIELD ACORN NUT KIT

Kit contains 10 chrome-plated low crown 12-24 acorn nuts.

94111-95 \$9.95

Fits Compact, King-Size, Convertible and Road King® windshields. (Pkg. of 10.)



A. WINDSHIELD ACORN NUT KIT

B. LOCKING QUICK-RELEASE WINDSHIELD CLAMPS

Protect your investment. This Locking Quick-Release Windshield Clamp secures your windshield from grab-and-run theft, giving you peace of mind when you have to leave your bike unattended. The chrome-plated locking clamp replaces one of the Original Equipment windshield clamps and features a push-button lock with a mini barrel-style key for easy removal. Kit includes one locking clamp and two matching keys.

57400006 39mm. \$39.95

Fits '88-later XL and '91-'05 Dyna® models (except FXDWG) equipped with Quick-Release style detachable windshields.

57400007 41mm. \$29.95

Fits '93-'05 FXDWG and '88-later FXS, FXST, FXSTB and FXSTC models equipped with Quick-Release style detachable windshields.

57400008 49mm. \$41.95

Fits '02-'10 VRSCA and VRSCAW, '04-'05 VRSCB, '07 VRSCX and '06-later Dyna models (except FLD) equipped with Quick-Release style detachable windshields.



B. LOCKING QUICK-RELEASE WINDSHIELD CLAMP

C. MID-FRAME AIR DEFLECTOR

Improve rider comfort during the summer riding season. Designed for severe duty and extreme temperature applications, these inconspicuous black deflectors attach to the frame and surround the top of the rear cylinder head. The scoop shape captures the moving air and uses the flow to direct the heat down and away from the rider to improve comfort. Kit includes all required mounting hardware.

29200011 \$84.95

Fits '06-later Dyna models. '06-'11 models require removal of Original Equipment coil cover and separate purchase of Coil Mounting Screws P/N 4717A (Qty 2). Does not fit with accessory Coil Covers P/N 31709-04 or 74616-04. Does not fit with Digital Oil Pressure Gauge P/N 75138-09 or 75340-09.

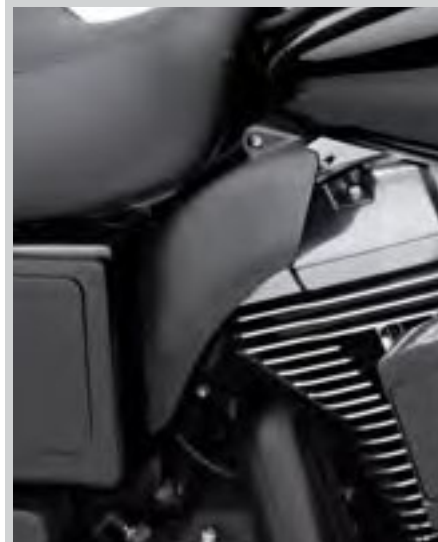

C. MID-FRAME AIR DEFLECTOR (DYNA SWITCHBACK SHOWN)

D. SOFT LOWERS

Extend your riding season. Full coverage Soft Lowers provide wind and mud protection for the rider's legs and boots and minimize cold updrafts as the weather changes. Covers are custom shaped to hug the engine guard to minimize flapping and they simply clip in place for speedy installation as the weather changes. Two-way zippered outer edge accommodates guard-mounted highway pegs in almost any position. Reflective piping provides added visibility and convenient zippered pockets provide additional storage for maps or other small items.

57100212 \$89.95

Fits '06-later FXD, FXDB, FXDC and FXDL models equipped with Engine Guard P/N 49010-06 or 49320-09. Does not fit models with forward controls or footboards.



E. TURN SIGNAL RELOCATION KIT

Styled to blend with the lower triple clamp. This chrome-plated Turn Signal Relocation Kit moves the Original Equipment bullet-style turn signals from the handlebar to the front fork for a clean, streamlined look. Kit includes left and right mounting stalk and all required hardware.

69433-08A \$89.95

Fits '08-later Dyna models (except FLD and FXDSE/2).



D. SOFT LOWERS



E. TURN SIGNAL RELOCATION KIT

Notice: The prices appearing in this catalog are the manufacturer's suggested retail prices. Actual retail prices may vary.

SEAT OF POWER

The right seat is equal parts ergonomics and comfort. Its shape anchors your position and determines the reach to the ground and to the controls and the padding supports your tailbone and hips to relieve stress and pressure. Pick the right one for you – and your passenger.

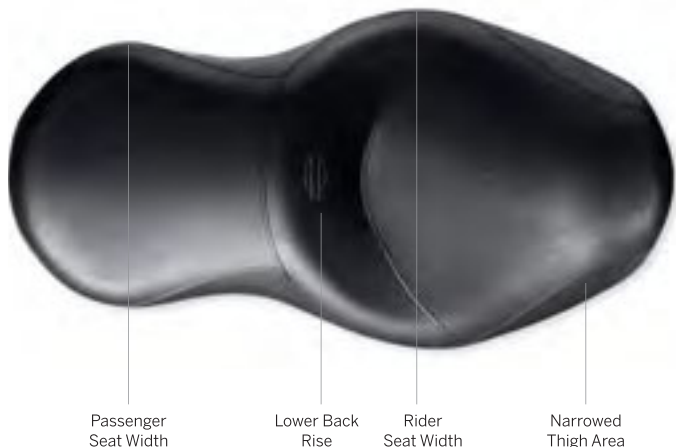

Passenger Seat Width

Lower Back Rise

Rider Seat Width

Narrowed Thigh Area

PAMPER YOUR BEHIND



Experience ultimate comfort. Road Zeppelin® seats and seat pads are equipped with a unique air bladder system that distributed rider weight across the entire seating surface. By reducing pressure points and providing shock absorption, this pad allows you to ride your cool low-profile seat for hundreds of miles. The mesh cover lets air circulate beneath the rider's body, reducing the temperature between the rider and seat. The easy-to-reach integrated hand pump and air release valve permits quick and convenient adjustment.

CHANGING YOUR SEAT



Switching out your seat is simple. And because certain rides call for certain styles, some folks like to have multiple seats to match the occasion. Install a comfortable, supportive touring seat for the longer treks and swap it out for a low-profile seat for a night on the town. Please see your owner's manual for proper removal and installation of seats.

DYNA® SEAT TYPES

Solo or two-up, comfort or style, check out these seats to get an idea of where you want to sit.



LOW-PROFILE SEATS

These saddles combine radical styling with a "deep-in-the-bike" riding position. Long and lean, Badlander®, Brawler® and Sidekick® seats bring you lower to the ground than most other seats.



POSITION SEATS

Designed to place the rider in the best relationship to the controls, Reach® and Tallboy® seats position short and tall riders for a comfortable extension of the arms and legs.



TOURING SEATS

Designed for comfort, Sundowner™ and Signature Series® and other touring seats and passenger pillion's offer a broad seating surface to reduce pressure points. The dished shape holds you in place and provides additional back support.

CUSTOM SEAT PROGRAM

A personalized seat is the perfect thread to tie your bike's attitude together. Select the stitching pattern, leather inlay and thread color that best support your custom movement and you'll have your personalized seat in just three weeks. For more details, turn to page 796 or visit h-d.com/customseat.



148 DYNA®

Seating – Solo

A. BOBBER SOLO SADDLE

How low can you go? This minimalist solo seat takes the stripped-down garage-built look about as far as you can go. The thick distressed black leather cover is bonded directly to the formed metal seat pan and minimizes the foam filler and the extra height it brings. The raw-edge leather features brass rivets and "Milwaukee Since 1903" trim that will develop a rich patina with use and a Bar & Shield logo burned into the surface. Easy to install, the bolt-on seat and model-specific Spring Seat Installation Kit includes everything you need to get the bobber look. No cutting, welding or fabrication is necessary.

52000180 Black Distressed Leather. **\$299.95**
Fits '04-'06 XL, '10-later XL, '06-later Dyna® and '08-later FXS, FLS, FLSTC, FLSTN, FLSTF and FLSTFB models.
Installation requires separate purchase of model-specific Rigid or Spring Saddle Mounting Hardware Kit.

B. SOLO SADDLE

Add nostalgic "bobber" looks to your modern Harley-Davidson® motorcycle. Available in elegant leather, this solo seat features a low-profile design that provides the minimalist "just enough to ride" look. The smooth metal seat pan and the simple frame cover leave a clean, finished appearance. Easy to install, the bolt-on seat and model-specific Spring Seat Installation Kit includes everything you need to get the bobber look. No cutting, welding or fabrication is necessary and the seat can be removed and replaced with a touring seat for a two-up night on the town.

Fits '04-'06 XL, '10-later XL, '06-later Dyna and '08-later FXS, FLS, FLSTC, FLSTN, FLSTF and FLSTFB models. Installation requires separate purchase of model-specific Rigid or Spring Saddle Mounting Hardware Kit.

54373-10	Black Leather.	\$299.95
54072-10	Brown Leather.	\$299.95
52000113	White Diamond.	\$299.95
52000114	Black Diamond.	\$299.95

Shown with:

SPRING SADDLE INSTALLATION KIT

The torsion-style springs are designed for the optimum balance between spring suspension and support. Required for installation of Solo Saddle Kit P/N 54072-10, 54373-10, 52000113, 52000114 and 52000180. Kit includes springs, mounting brackets, frame cover and hardware.

54075-10 **\$229.95**
Fits '06-later Dyna models.

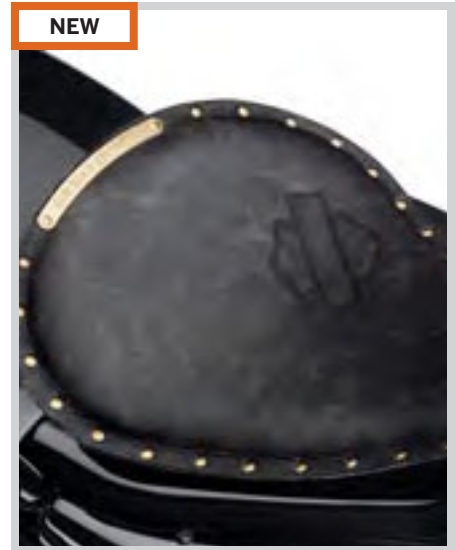

A. BOBBER SOLO SADDLE – BLACK DISTRESSED LEATHER (SHOWN WITH SPRING SADDLE INSTALLATION KIT)



B. SOLO SADDLE – BLACK LEATHER (SHOWN WITH SPRING SADDLE INSTALLATION KIT)

B. SOLO SADDLE – BROWN LEATHER (SHOWN WITH SPRING SADDLE INSTALLATION KIT)

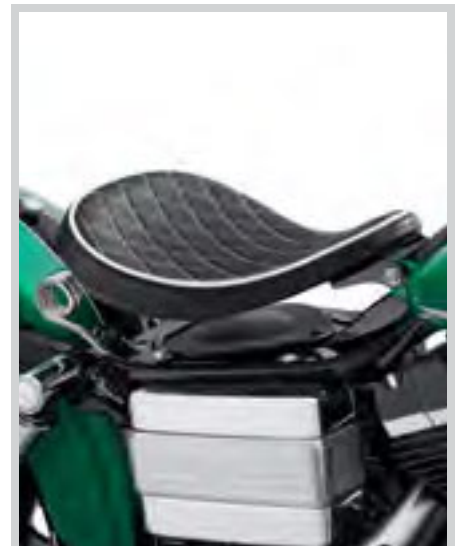
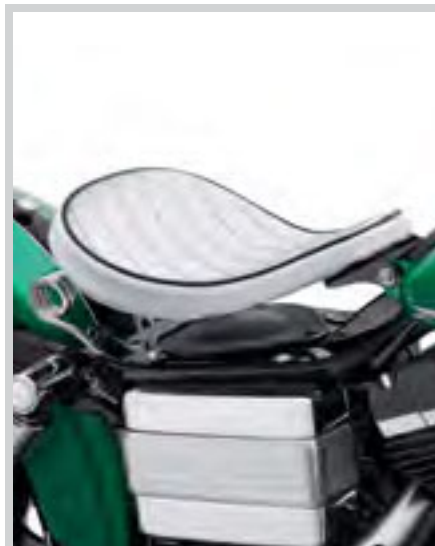

B. SOLO SADDLE – WHITE DIAMOND (SHOWN WITH SPRING SADDLE INSTALLATION KIT)

B. SOLO SADDLE – BLACK DIAMOND (SHOWN WITH SPRING SADDLE INSTALLATION KIT)

Note: Some Harley-Davidson seats are made of leather. Fine leathers or other natural materials WILL gain "character," such as wrinkles or wear, with age. This is normal. A fine, aged patina and character wrinkles are a sign of the extremely high quality materials used to construct your seat or backrest. The appearance of scars or marks on the leather are a result of using natural leather panels and should not be thought of as an imperfection. Please use Harley-Davidson Leather Protectant P/N 93600034 to protect your investment.

Notice: The prices appearing in this catalog are the manufacturer's suggested retail prices. Actual retail prices may vary.

DYNA® 149

Seating – Solo



C. BRAWLER SOLO SEAT

C. BRAWLER® SOLO SEAT

When it's time to go it alone, go solo in style. These premium quality cowhide leather saddles are designed to create a subtle and distinctive look. Top-grain leather seating surfaces and contoured foam padding add long-haul comfort and the durable hand-laid fiberglass seat pan is carpeted to protect the paint finish. Does not fit with passenger pillions.

51375-06

\$349.95

Fits '06-later Dyna® models. Seat width 12.5".

D. SIDEKICK® SEAT

Share your custom ride. The two-up design of these premium cowhide leather seats offers a frame-hugging look, but adds back support for the rider and additional padding for the passenger. Top-grain leather seating surfaces and contoured foam padding add long-haul comfort and the durable hand-laid fiberglass seat pan is carpeted to protect the paint finish.

51353-06

\$399.95

Fits '06-later Dyna models. FXD and FXDB models require separate purchase of Passenger Footpegs and Passenger Footpeg Mounting Kit P/N 50210-06. Seat width 12.5"; passenger pillion width 6.0".



D. SIDEKICK SEAT

Notice: The prices appearing in this catalog are the manufacturer's suggested retail prices. Actual retail prices may vary.

To add custom inlays and stitching to your Brawler® or Sidekick® seat, see pages 796-797, or visit: www.h-d.com/customseat.



150 DYNA®

Seating – Solo & Pillion

A. SUNDOWNER™ SOLO SEAT

Ride solo on your Dyna® motorcycle in Sundowner™ comfort and style. This unique seat combines the deep bucket design and added back support of the two-up seat with the stripped-down look of a solo saddle. Matching passenger pillion is available for added versatility.

51933-06 **\$249.95**
Fits '06-later Dyna® models. Seat width 14.5".

51933-01 **\$249.95**
Fits '96-'03 Dyna models. Seat width 14.5".

Shown with:

SUNDOWNER PASSENGER PILLION

Bring someone along for the ride without giving up your solo status. This carefully styled pillion matches Dyna Sundowner Solo Seat and provides your passenger with that great Sundowner comfort.

51473-06A **\$159.95**
Fits '06-later Dyna models equipped with Sundowner™ Solo Seat P/N 51933-06 or '06-'08 FXDB and '06-'09 FXDWG models equipped with Original Equipment solo seat. FXD and FXDB models require separate purchase of Passenger Footpegs and Passenger Footpeg Mounting Kit P/N 50210-06. Pillion width 12.0".

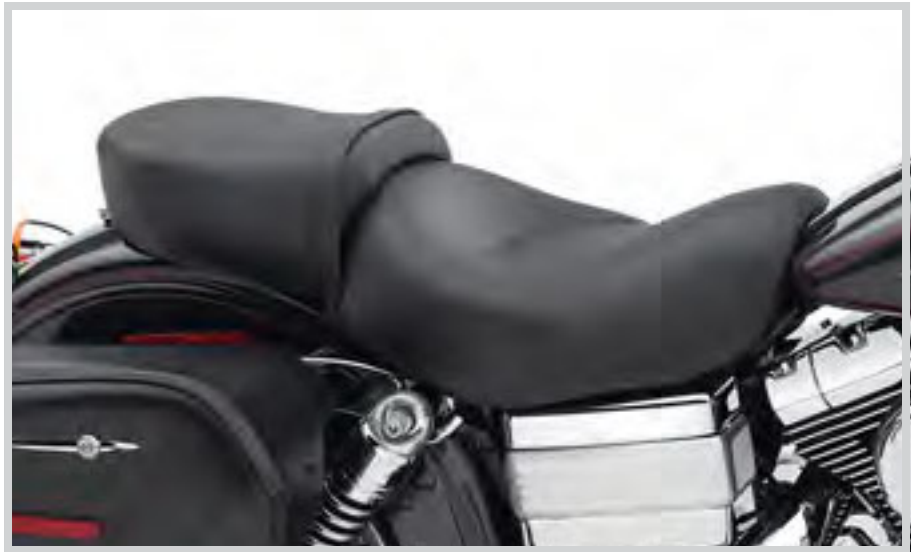

**A. SUNDOWNER SOLO SEAT
(SHOWN WITH SUNDOWNER PASSENGER PILLION)**

B. H-D® DETACHABLES™ PASSENGER PILLION

Styled to complement stock or accessory solo seats, this Passenger Pillion delivers maximum passenger comfort on the road. The pillion is easily removable from the Solo Rack P/N 52796-09 with a simple finger-pull release. The available Sissy Bar Upright P/N 52726-09 attaches directly to the pillion to provide a completely removable touring system.

52689-09 **\$219.95**
Fits '06-later Dyna models (except FXDF, FXDFSE and '10-later FXDWG) with solo seats. Installation requires separate purchase of Rigid Solo Rack P/N 52796-09. FXD and FXDB models require separate purchase of Passenger Footpegs and Passenger Footpeg Mounting Kit P/N 50210-06. Pillion width 11.0".

C. PASSENGER Sissy BAR UPRIGHT

Styled to blend with the muscular look of the Dyna family, this gloss black upright attaches directly to the passenger pillion for a clean look. Combine with Backrest Pad P/N 51782-07 for a complete touring system.

52726-09 Gloss Black. **\$59.95**
Fits '06-later Dyna models (except FLD, FXDF, FXDFSE/2 and '10-later FXDWG) with solo seats. Installation requires separate purchase of Rigid Solo Rack P/N 52796-09 and Passenger Pillion P/N 52689-09.

Shown with:

SMOOTH LOOK PASSENGER BACKREST PAD

This backrest sports a smooth, clean finish that looks great with any smooth surface seat.

51782-07 **\$79.95**
Fits '07-'11 VRSC (except VRSCF), '06-'07 VRSCR and '06 VRSCSE2 models equipped with Sissy Bar Upright P/N 51162-06 or 51313-07, '06-later Dyna models equipped with Sissy Bar Upright P/N 52726-09.



**B. H-D DETACHABLES PASSENGER PILLION –
REMOVED**

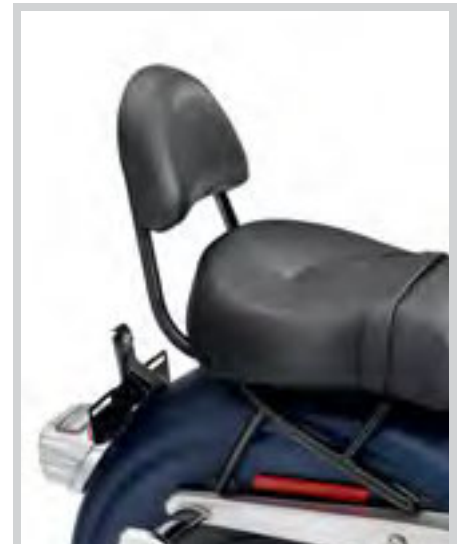

**C. PASSENGER Sissy BAR UPRIGHT
(SHOWN WITH SMOOTH LOOK BACKREST PAD)**

D. PASSENGER PILLION – SMOOTH STYLING

Bring a passenger along for the ride. This Passenger Pillion includes a passenger grab strap.

51404-10 Smooth. **\$144.95**
Fits '09-later FXDB and '10-later FXDWG models with Original Equipment solo seat. Installation on FXDB models requires separate purchase of Passenger Footpegs and Passenger Footpeg Mounting Kit P/N 50210-06.

51535-06A Smooth. **\$149.95**
Fits '06-'09 Dyna models (except '09 FXDB). FXD and FXDB models require separate purchase of Passenger Footpegs and Passenger Footpeg Mounting Kit P/N 50210-06. Pillion width 9.5".

51474-06A Super Glide Texture. **\$149.95**
Fits '06-'09 Dyna models (except '09 FXDB). FXD and FXDB models require separate purchase of Passenger Footpegs and Passenger Footpeg Mounting Kit P/N 50210-06. Pillion width 9.5".



D. PASSENGER PILLION – SMOOTH STYLING



**D. PASSENGER PILLION –
DYNA SUPER GLIDE TEXTURE**

Notice: The prices appearing in this catalog are the manufacturer's suggested retail prices. Actual retail prices may vary.



E. LEATHER BADLANDER SEAT

E. LEATHER BADLANDER® SEAT

The traditional Badlander® Seat, with a low and lean style is enhanced with supple top-grain leather and an embroidered "H-D" logo. Kit includes leather care product, seat, grab strap and mounting hardware.

52359-06 \$379.95

Fits '06-later Dyna® models. FXD and FXDB models require separate purchase of Seat Bumper Kit P/N 51653-06, Passenger Footpegs and Passenger Footpeg Mounting Kit P/N 50210-06. Seat width 11.0"; passenger pillion width 5.0".

F. BADLANDER SEAT

The popular Harley-Davidson® Badlander Seat is aggressively styled with a clean, smooth shape that flows from the fuel tank into the rear fender. Subtle top-stitching and the dual embroidered "Harley-Davidson" script logo add the finishing touches.

52284-06 \$274.95

Fits '06-later Dyna models. FXD and FXDB models require separate purchase of Seat Bumper Kit P/N 51653-06, Passenger Footpegs and Passenger Footpeg Mounting Kit P/N 50210-06. Seat width 11.0"; passenger pillion width 5.0".

52284-04 \$274.95

Fits '04-'05 Dyna models. Seat width 11.0"; passenger pillion width 5.0".

52284-96A \$274.95

Fits '96-'03 Dyna models. Seat width 11.0"; passenger pillion width 5.0".

G. LOW-PROFILE LEATHER SEAT

Prowl the town in style. Featured as Original Equipment on the '07 CVO™ Dyna model, this low-profile seat features a breathable perforated leather insert. The firm padding makes you feel a part of the bike and the raised back stop keeps you in place when you hit the gas.

52378-07 \$349.95

Fits '06-later Dyna models. FXD and FXDB models require separate purchase of Passenger Footpegs and Passenger Footpeg Mounting Kit P/N 50210-06. Seat width 12.0"; passenger pillion width 7.0".



F. BADLANDER SEAT



G. LOW-PROFILE LEATHER SEAT

Note: Some Harley-Davidson seats are made of leather. Fine leathers or other natural materials WILL gain "character," such as wrinkles or wear, with age. This is normal. A fine, aged patina and character wrinkles are a sign of the extremely high quality materials used to construct your seat or backrest. The appearance of scars or marks on the leather are a result of using natural leather panels and should not be thought of as an imperfection. Please use Harley-Davidson Leather Protectant P/N 93600034 to protect your investment.

Notice: The prices appearing in this catalog are the manufacturer's suggested retail prices. Actual retail prices may vary.

152 DYNA®

Seating – Two-Up

A. SUPER REDUCED REACH® SOLO SEAT

Get a little bit closer. Super Reduced Reach® forward position seats are designed to move riders with a shorter inseam even closer to the controls and to bring the legs about 1.0" closer together so that your feet rest firmly on the pavement. The scooped bucket-shaped saddle is enhanced with added back support padding to move the rider up to 1.0" lower and 3.0" forward. The combination positions the rider closer to the hand and foot controls to offer both comfort and confidence. For a two-up ride, combine the solo seat with the Touring Passenger Pillion P/N 51404-10 (sold separately).

54384-11 **\$239.95**

Fits '06-later Dyna® models. Seat width 10.5".



A. SUPER REDUCED REACH SOLO SEAT

B. REDUCED REACH SEAT

Designed specifically for riders requiring a close to the bar riding position, this seat positions the rider approximately 1.0" forward, closer to the hand and foot controls. The narrow front profile brings your legs closer together to help you plant your feet firmly on the ground. The seat features a textured vinyl insert and a "Harley-Davidson" logo that shows you are riding in style.

52288-06 **\$299.95**

Fits '06-later Dyna models. FXD and FXDB models require separate purchase of Seat Bumper Kit P/N 51653-06, Passenger Footpegs and Passenger Footpeg Mounting Kit P/N 50210-06. Seat width 12.0"; passenger pillion width 9.0".



B. REDUCED REACH SEAT

C. RALLYRUNNER® SEAT

Share your custom ride. The two-up design of these premium cowhide leather seats offers a frame-hugging look, but adds back support for the rider and additional padding for the passenger. Top-grain leather seating surfaces and contoured foam padding add long-haul comfort and the durable hand-laid fiberglass seat pan is carpeted to protect the paint finish.

51369-06 **\$399.95**

Fits '06-later Dyna models. FXD and FXDB models require separate purchase of Passenger Footpegs and Passenger Footpeg Mounting Kit P/N 50210-06. Seat width 12.5"; passenger pillion width 8.0".



C. RALLYRUNNER SEAT

Note: Some Harley-Davidson® seats are made of leather. Fine leathers or other natural materials WILL gain "character," such as wrinkles or wear, with age. This is normal. A fine, aged patina and character wrinkles are a sign of the extremely high quality materials used to construct your seat or backrest. The appearance of scars or marks on the leather are a result of using natural leather panels and should not be thought of as an imperfection. Please use Harley-Davidson Leather Protectant P/N 93600034 to protect your investment.

Notice: The prices appearing in this catalog are the manufacturer's suggested retail prices. Actual retail prices may vary.

DYNA® 153

Seating – Two-Up



**D. SUNDOWNER SEAT
(SHOWN WITH SMOOTH BUCKET PASSENGER BACKREST PAD)**



**E. SIGNATURE SERIES SEAT WITH RIDER BACKREST
(SHOWN WITH SMOOTH LOW PASSENGER BACKREST PAD)**



F. TALLBOY SEAT

D. SUNDOWNER™ SEAT

The Sundowner™ Seat provides the maximum in long-riding comfort. The deep-bucket design puts your body in the proper touring position and the generous padding makes it comfortable for both the rider and passenger as the miles are adding up. The dish shape provides added rider back support and the wide passenger pillion is shaped to minimize pressure points.

51540-06 **\$339.95**

Fits '06-later Dyna® models. FXD and FXDB models require separate purchase of Seat Bumper Kit P/N 51653-06, Passenger Footpegs and Passenger Footpeg Mounting Kit P/N 50210-06. Seat width 16.0"; passenger pillion width 12.0".

51540-04 **\$339.95**

Fits '04-'05 Dyna models. Seat width 16.0"; passenger pillion width 12.0".

51540-01A **\$339.95**

Fits '96-'03 Dyna models. FXDWG models require separate purchase of Bracket P/N 52152-97. Seat width 16.0"; passenger pillion width 12.0".

E. SIGNATURE SERIES® SEAT WITH RIDER BACKREST

A perfect combination of foam density and shape has created our most comfortable seat for long-haul touring. Both rider and passenger will be extra comfy riding to Sturgis and back with the wide-seating area. When you reach your destination, city driving will be easier with the narrow nose that helps keep your legs closer together. Seat features an easily removable adjustable rider backrest that folds down for easier passenger mounting. Rider backrest has a 5-position height adjustment with 1.5" range and a wide range of forward/back angle adjustment with a quick twist of the control knob.

52000015 **\$549.95**

Fits '06-later Dyna models. FXD and FXDB models require separate purchase of Seat Bumper Kit P/N 51653-06, Passenger Footpegs and Passenger Footpeg Mounting Kit P/N 50210-06. Seat width 16.0"; passenger pillion width 12.0".

F. TALLBOY® SEAT

Stretch your legs in style. The Tallboy® one-piece seat moves the rider back 1.75" and up 2.0" as compared to the Original Equipment seat. The new position allows additional leg and arm movement for the long-limbed rider and a comfortable seating space for the open road. The Tallboy Seat also features a wide pillion for added passenger comfort.

51471-06 **\$299.95**

Fits '06-later Dyna models. FXD and FXDB models require separate purchase of Seat Bumper Kit P/N 51653-06, Passenger Footpegs and Passenger Footpeg Mounting Kit P/N 50210-06. Seat width 16.0"; passenger pillion width 12.0".

Note: Some Harley-Davidson® seats are made of leather. Fine leathers or other natural materials WILL gain "character," such as wrinkles or wear, with age. This is normal. A fine, aged patina and character wrinkles are a sign of the extremely high quality materials used to construct your seat or backrest. The appearance of scars or marks on the leather are a result of using natural leather panels and should not be thought of as an imperfection. Please use Harley-Davidson Leather Protectant P/N 93600034 to protect your investment.

Notice: The prices appearing in this catalog are the manufacturer's suggested retail prices. Actual retail prices may vary.

154 DYNA®

Seating – Two-Up

A. ROAD ZEPPELIN® AIR ADJUSTABLE SEAT

The mating of comfort and style. Low-profile Road Zeppelin® Seats are equipped with a unique adjustable air bladder system that distributes your weight across the seating surface. The air bladder system removes pressure points and provides shock absorption for the rider's and passenger's tailbone. You get hours of riding comfort without sacrificing the low-slung custom look. The combination of smooth vinyl and waterproof textured fabric seating surfaces allows air to circulate beneath the body, reducing the air temperature between the rider and seat. The easy-to-reach integrated hand pumps and air release valves permit quick and convenient adjustment for both the rider and passenger.

52000147 **\$549.95**

Fits '06-later Dyna® models. Models not equipped with passenger pegs require separate purchase of Passenger Footpegs and Passenger Footpeg Mounting Kit P/N 50210-06. Seat width 13.0", passenger pillion width 10.5".



A. ROAD ZEPPELIN AIR ADJUSTABLE SEAT

B. ROAD ZEPPELIN SEAT PAD

Experience ultimate comfort. Road Zeppelin Seat Pads are equipped with a unique air bladder system that allows your weight to be distributed evenly across the entire seating surface, ensuring hours of comfort for both rider and passenger. The air bladder system is designed to remove pressure points and provide shock absorption to reduce vibration. The mesh cover allows air to circulate beneath the rider's body, reducing the air temperature between the rider and seat. The easy-to-reach integrated hand pump and air release valve permits quick and convenient adjustment. Shaped to conform to most Harley-Davidson® seats, the pads feature an adjustable mounting strap and a non-skid surface to keep them in place.

52000084 Rider. **\$129.95**

Fits rider position on all models equipped with Original Equipment or accessory seats. Also fits passenger position on Touring models with large pillion area. Pad width – 14.0".

52400060 Passenger Pillion. **\$129.95**

Fits Original Equipment and accessory passenger pillions. Pad length – 11.0"; width – 8.0".



B. ROAD ZEPPELIN SEAT PAD

C. CIRCULATOR SEAT PADS

Keep comfortable on your next long ride. These breathable Circulator Seat Pads feature 3D construction that promotes air movement and reduces heat build-up where the rider's body touches the seat and backrest. Designed to keep the rider cool by reducing the perspiration build-up between you and the seating surface, the Circulator Pad can be installed and removed in seconds for easy cleaning. The low-profile design minimizes seat-height change compared to inflatable pads, while enhancing comfort with its shock-absorbing construction. Manufactured of UV-stable materials, these seat pads resist fading when exposed to the sun. Elastic under-seat strap and non-slip base provide secure installation and the available Circulator Passenger Pillion Pad attaches to the rider pad with hook-and-loop tabs.

51074-10 Medium Seat Pad. **\$79.95**

Fits VRSC™, XG, XL and Dyna models with Original Equipment and accessory seats. Pad width – 14.5"

51078-10 Passenger Pillion Pad. **\$69.95**

Fits Original Equipment and accessory passenger pillions. Pad width – 13.0"



C. CIRCULATOR SEAT PADS

Notice: The prices appearing in this catalog are the manufacturer's suggested retail prices. Actual retail prices may vary.



D. RAIN COVER – TWO-UP SEAT

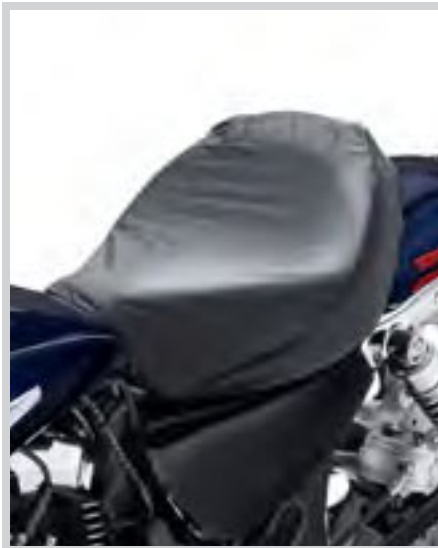

D. RAIN COVER – SOLO SEAT

D. RAIN COVERS*

Featuring a handy storage sack, this black nylon, water-resistant, Cordura® cover packs easily and shelters your seat from the storm.

51637-97 Two-Up Seat. **\$31.95**
Fits H-D® two-up seats (except XR, FLSTC and FLSTS seats with rider backrests).

51638-97 Solo Seat. **\$29.95**
Fits H-D solo seats (except XR and FLSTS).

52952-97 Seat with Rider Backrest (not shown). **\$39.95**
Fits most seats with rider backrest. Does not fit Trike models.

E. BILLET SEAT MOUNTING BRACKET – CHROME

The highly stylized design of this bracket adds a stunning new look to the back of most seats.

51804-02 **\$19.95**
Replaces Bolt-On Seat Brackets P/N 51798-00, 51740-10, 52467-00, 51652-97A and 51652-83B used on most Original Equipment and accessory seats and pillions.

F. QUICK-RELEASE SEAT HARDWARE KIT

This Hardware Kit allows the rider to remove one-piece Harley-Davidson® seats quickly and easily.

51676-97A **\$19.95**
Fits '97-later XG, XL, Dyna®, Softail® (except FLS models equipped with Original Equipment seat) and Touring models. Does not fit seats equipped with spring-loaded rear seat bracket.

G. REAR FENDER BIB

Go solo in style. Form-fitted to hug the contour of the rear fender, this decorative fender cover hides the seat mounting holes that are exposed when riding with a solo seat. Wrapped in smooth vinyl to match Original Equipment or accessory solo seats, the Fender Bib features an embossed Bar & Shield logo for added style. The molded base is finished with a soft felt under-liner designed to protect the fender's painted surface.

52036-08 **\$59.95**
Fits '06-later Dyna models equipped with Original Equipment solo seat, Brawler® Solo Seat or Sundowner™ Solo Seat.

H. TANK BRA

This Tank Bra is made with nonabrasive, fleece-backed vinyl material and features an embroidered Bar & Shield logo. It protects your fuel tank from scratches from keys, belt buckles and other objects. Designed for easy installation and a custom fit without disassembly of the tank or seat.

62028-04 **\$42.95**
Fits '04-later Dyna models.

57799-00 **\$43.95**
Fits '93-'03 FXDWG and '00-later Softail models (except FXCW, FXCWC, FXS, FXSB, FXSTD, FXSTSE, FXSTSSE/2/3, '09-later FLS, FLSTC, FLSTFSE2, FLSTSB, FLSTSE/2/3).



E. BILLET SEAT MOUNTING BRACKET – CHROME



F. QUICK-RELEASE SEAT HARDWARE KIT



G. REAR FENDER BIB



H. TANK BRA



***WARNING:** Do not use while riding; could result in death or serious injury.

Notice: The prices appearing in this catalog are the manufacturer's suggested retail prices. Actual retail prices may vary.

156 DYNA®

Backrests & Racks

Choosing a Backrest

A sissy bar upright and passenger backrest are the starting point to build a complete touring machine. The backrest provides long-range comfort and support and adds a feeling of control and confidence for the passenger. For permanent installation, choose rigid sideplates and a style of upright that suits your riding style. For added flexibility, choose a H-D® Detachables™ sideplate kit and appropriate Docking Hardware to make adding or removing a detachable accessory a simple "slide and click" proposition.



H-D® Rigid Sideplates

Add practical comfort and support for your passenger. Rigid Sideplates supports are the anchor for sissy bar uprights, backrest pads and luggage racks, and hug the rear fender strut for a clean, streamlined look. Manufactured and tested to rigorous Harley-Davidson standards, these sideplates are designed to specific model application for exact fit.

1. Fits '06-later Dyna® models (except FLD, FXDWG, FXDF and FXDFSE/2).

52856-06 Chrome. **\$94.95**

2. Fits '08-'13 FXDF and FXDFSE/2, '06-'08 FXDWG models.

53020-06A Chrome. **\$109.95**

3. Fits '96-'05 FXD and FXDL models (standard on '96-'00 FXDS-CONV.). Also fits '99 and '02-'05 FXDX and '01-'05 FXDXT models.

52783-96B Chrome. **\$104.95**

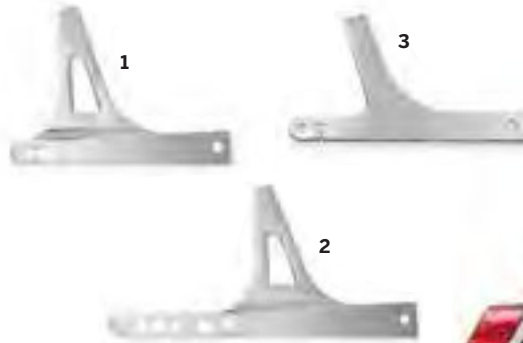

H-D® Detachables™ Sideplates

4. Fits '06-later Dyna models (except FLD and '13-later FXDB HDI and India configuration). Requires separate purchase of appropriate Docking Hardware kit. '13-later FXDB models equipped with a side-mount license plate require License Plate Relocation Kit P/N 67900130. Not for use with LED Rear Turn Signal Kit P/N 67800055 or 67800056.

52866-06 Chrome. **\$144.95**

52124-09 Gloss Black. **\$144.95**

5. Fits '12-later FLD models. Requires separate purchase of Docking Hardware Kit P/N 52300065.

52300070 Chrome. **\$144.95**

6. Fits '93-'05 FXDWG models. '93-'01 models using these sideplates in combination with Luggage Rack P/N 53711-96A, 53852-00 or 53866-00 require separate purchase of Adapter Kit P/N 53828-00. ('02-later models with Luggage Rack P/N 53899-02 do not require Adapter Kit.) (Not for use with Saddlebags.)

53870-01A Chrome. **\$144.95**

Fits '96-'05 Dyna models (except FXDWG and FXDXT). '96-'01 models using these sideplates in combination with Luggage Racks P/N 53711-96A, 53852-00 or 53866-00 require separate purchase of Luggage Rack Adapter Kit P/N 53828-00.

53543-95A Chrome. **\$144.95**



H-D Adjustable Sideplates

Enhance your passenger's ride with an adjustable passenger backrest. When combined with your choice of Sissy Bar Upright and Backrest Pad, these Premium Adjustable Sideplates allow the passenger to change the recline angle of the passenger backrest for maximum comfort. Simply pull on the release levers and adjust the upright to one of three different recline settings. The exclusive cam lock detachable design lets you add or remove the passenger backrest assembly in seconds.

Fits '06-later Dyna models (except FLD and '13-later FXDB HDI and India configuration). Requires separate purchase of appropriate Docking Hardware kit. '13-later FXDB models equipped with a side-mount license plate require License Plate Relocation Kit P/N 67900130. Not for use with LED Rear Turn Signal Kit P/N 67800055 or 67800056.

52300110 Chrome. **\$239.95**

52300090 Gloss Black. **\$239.95**



Notice: The prices appearing in this catalog are the manufacturer's suggested retail prices. Actual retail prices may vary.

Select a Height



Tall

Tall Sissy Bar Upright

Let your passenger ride tall in the saddle with a Tall Sissy Bar Upright. This upright provides maximum upper back support when equipped with your choice of Backrest Pad.



Standard

Standard Sissy Bar Upright

Give your passenger additional back support with a Standard Sissy Bar Upright, designed to accept a wide variety of Backrest Pads.



Low

Low Sissy Bar Upright

Shaped to complement a thicker passenger pillion, this Low Sissy Bar Upright stands between the Standard and Short Sissy Bar Upright. The ideal match for touring style seats, this upright also offers an additional height option to riders with custom style seats.



Short

Short Sissy Bar Upright

This Short Sissy Bar Upright is lower than traditional low uprights and the hidden Backrest Pad Mounting System allows for a sleek look when the pad is removed.

Select a Style



Square Bar Medallion Style with 3-Bolt Pad Mount



Round Bar Mini Medallion Style with 3-Bolt Pad Mount



Round Bar Mini Medallion Style with 2-Bolt Pad Mount

Sissy Bar Uprights are available in a variety of shapes and styles. Square bar uprights feature a traditional plate design that provides a flat surface that is ideal for displaying self-adhesive medallions. Round bar uprights feature a mini medallion bar and an embossed Bar & Shield insert. Uprights are designed to accept specific 3-bolt or 2-bolt mounted backrest pads.

Select Your Model

Square Bar Upright

Height	Style	Finish	'91-'01 Dyna® models, '82-'00 FXR models		'02-'05 Dyna models		'06-later Dyna models (except FXDF, FXDFSE/2 and '10-later FXDWG)		'08-'09 FXDF and FXDFSE models	
			Part No.	Price	Part No.	Price	Part No.	Price	Part No.	Price
Short	Insert	Chrome	—	—	51513-02	\$74.95	52737-94A	\$74.95	—	—
Short	Insert	Gloss Black	—	—	—	—	52706-07	\$74.95	—	—
Low	Medallion	Chrome	52655-84	\$89.95	52909-02	\$89.95	52754-04	\$99.95	—	—
Low	Medallion	Gloss Black	—	—	—	—	51851-09	\$99.95	—	—
Standard	Medallion	Chrome	—	—	—	—	52735-85	\$89.95	52877-08	\$89.95
Tall	Medallion	Chrome	52777-85A	\$99.95	—	—	—	—	—	—

Round Bar Upright

Height	Style	Finish	Fits '10-later FXDF, FXDFSE2 and FXDWG models		Fits '06-later Dyna models (except FXDF, FXDFSE/2 and '10-later FXDWG)					
			Part No.	Price	Part No.	Price	Part No.	Price	Part No.	Price
Low	Mini Medallion	Chrome	52300049	\$89.95	52300022	\$99.95	—	—	—	—
Low	Mini Medallion	Gloss Black	52300050	\$89.95	52300024	\$99.95	—	—	—	—
Standard	Mini Medallion	Chrome	52877-10	\$89.95	52300018	\$99.95	—	—	—	—
Standard	Mini Medallion	Gloss Black	51168-10	\$89.95	52300020	\$99.95	—	—	—	—

158 DYNA®

Backrests & Racks



Typical H-D® Detachables™ Docking Hardware Kit



Select the Docking Hardware

Dyna® Docking Hardware for H-D® Detachables™ Racks and Sideplates

Docking hardware fitment is dependent on vehicle model and saddlebag configuration.

H-D Detachables Accessory

No Saddlebags: Adjustable Sideplates 52300110 (Chrome), 52300090 (Gloss Black), Detachable Sideplates 52124-09 (Gloss Black), 53543-95A (Chrome), 53834-00A (Wrinkle Black), 52866-06 (Chrome), 53870-01A (Chrome), Detachable Solo Rack 53511-06, One-Piece Detachable Uprights 51161-10 (Gloss Black), 52300042 (Chrome), One-Piece Detachable Uprights 52300044 (Chrome), 52300046 (Gloss Black)

With P&A Saddlebags: Adjustable Sideplates 52300110 (Chrome), 52300090 (Gloss Black), Detachable Sideplates 52124-09 (Gloss Black), 53543-95A (Chrome), 53834-00A (Wrinkle Black), 52866-06 (Chrome), Detachable Solo Rack 53511-06, One-Piece Detachable Uprights 51161-10 (Gloss Black), 52300042 (Chrome), One-Piece Detachable Uprights 52300044 (Chrome), 52300046 (Gloss Black)

With P&A Saddlebags: 79300-06D, 88200-09A, 88348-10, 90181-08A, 90307-98, 90369-02, 90369-06D, 90564-02, 90564-06D, 91617-03, 91615-09A, 90126-YYXXX

With Original Equipment Saddlebags: Detachable Sideplates 52300070 (Chrome)

Available to fit:

		Required Docking Hardware		Directional Relocation Kit	
	1999 FXDX, 1996-2001 FXD & FXDL	53527-95B	\$49.95	—	—
	2002-2005 FXD, FXDC, FXDL & FXDX	53533-02B	\$49.95	—	—
	2001 FXDWG2, 2002 FXDWG3 & 2002-2005 FXDWG	53882-02B	\$59.95	—	—
	2006-2008 FXDWG & 2008-2009 FXDF and FXDFSE/2	53964-06B	\$29.95	—	—
	2006-later FXD, FXDC, FXDL and FXDSE/2, 2006-2008 FXDB	53961-06	\$49.95	53968-06C	\$49.95
	2009-later FXDB (except 2013-later HDI and India configuration)	53797-09	\$69.95	53968-06C	\$49.95
	2010-later FXDWG	54097-10	\$49.95	53968-06C	\$49.95
	2010-later FXDF	53964-06B	\$29.95	—	—
	1999 FXDX, 1996-2001 FXD & FXDL	53527-95B	\$49.95	—	—
	2002-2005 FXD, FXDC, FXDL & FXDX	53533-02B	\$49.95	—	—
	2006-2008 FXDWG & 2008-2009 FXDF and FXDFSE/2	53964-06B	\$29.95	—	—
	2006-later FXD, FXDC, FXDL and FXDSE/2, 2006-2008 FXDB	53961-06	\$49.95	—	—
	2009-later FXDB	53797-09	\$69.95	68227-09	\$109.95
	2010-later FXDWG	54097-10	\$49.95	53968-06C	\$49.95
	2010-later FXDF	53964-06B	\$44.95	—	—
	2012-later FLD	52300065	\$99.95	—	—

Notice: The prices appearing in this catalog are the manufacturer's suggested retail prices. Actual retail prices may vary.

DYNA® 159

Backrests & Racks



A. ONE-PIECE H-D DETACHABLES SISSY BAR UPRIGHT – CHROME



A. ONE-PIECE H-D® DETACHABLES™ SISSY BAR UPRIGHT

The sweeping shape of this slim, round bar Sissy Bar Upright completes the classic “bobber” look. The one-piece design eliminates separate sideplates for a clean appearance and the stylized upper kick angle mimics the old-school sissy bars of the '50s and '60s. Available in chrome and gloss black finishes, these bars can be equipped with Passenger Backrest Pad P/N 52631-07.

Fits '06-later Dyna® models (except FLD, FXDF, FXDFSE/2, '10-later FXDWG and '13-later FXDB HDI and India configuration). Requires separate purchase of appropriate Docking Hardware kit. '13-later FXDB models equipped with a side-mount license plate require License Plate Relocation Kit P/N 67900130. Not for use with LED Rear Turn Signal Kit P/N 67800055 or 67800056.

52300044	Chrome.	\$199.95
52300046	Gloss Black.	\$199.95

Fits '10-later FXDWG and FXDF models. Installation requires separate purchase of appropriate Docking Hardware Kit. Dyna Wide Glide® models require separate purchase of Docking Hardware Kit P/N 54097-10 and Turn Signal Relocation Kit P/N 53968-06C.

52300042	Chrome.	\$199.95
51161-10	Gloss Black.	\$199.95

B. LOCKING H-D DETACHABLES LATCH KIT

This unique lock replaces the camlock on your Harley-Davidson® Detachables™ accessories, providing additional security and peace of mind when parking your vehicle. The kit includes two extended-reach barrel-style keys for easy access to the lock. Key registration and replacement service is available. Sold in pairs.

Fits all models equipped with detachable Sideplates, Racks and Tour-Pak® Luggage Carriers (except '09-later Touring models equipped with detachable Solo Tour-Pak Rack).

90300087	Chrome.	\$79.95
90300086	Black.	\$69.95

C. H-D DETACHABLES LATCH KIT – CHROME

Decorative chrome latches are the perfect way to enhance the appearance of your detachable accessories. Meticulously polished and chrome-plated, these easy-to-install Rotary Latches are a direct replacement for the Original Equipment satin black parts and are a simple way to add a finishing touch to your ride. Latches feature an easy-to-pull finger release to simplify access in hard-to-reach areas.

12600036		\$49.95
-----------------	--	----------------

Fits all models equipped with detachable Sideplates, One-Piece Sissy Bar Uprights, Racks and Tour-Pak Luggage Mounting Racks.



A. ONE-PIECE H-D DETACHABLES SISSY BAR UPRIGHT – GLOSS BLACK



B. LOCKING H-D DETACHABLES LATCH KIT – CHROME



B. LOCKING H-D DETACHABLES LATCH KIT – BLACK



C. H-D DETACHABLES LATCH KIT – CHROME

Notice: The prices appearing in this catalog are the manufacturer's suggested retail prices. Actual retail prices may vary.

160 DYNA®

Backrests & Racks

PASSENGER BACKREST PADS

Choose from a wide variety of backrest pad sizes and shapes to match your comfort and style demands. Designed to complement Original Equipment and accessory seats, these pads are engineered to fit specific sissy bar upright types.

A. SLIP-OVER PASSENGER BACKREST PAD

This Slip-Over Backrest Pad provides a touch of passenger comfort, while maintaining the long, lean style of the Dyna® Wide Glide® model. Held in place with hook-and-loop tabs, this rich black pad features grey stitching that complements the Original Equipment seat and pillion.

51732-10 **\$69.95**
Fits '10-later FXDWG models with Original Equipment sissy bar upright.



A. SLIP-OVER PASSENGER BACKREST PAD

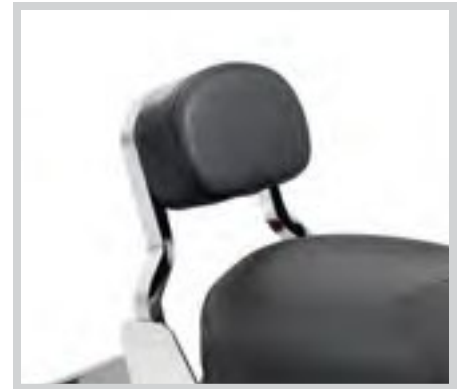

B. SHORT BACKREST PAD

B. SHORT BACKREST PAD

Innovative Backrest Pad Mounting System features a brushed stainless steel insert framed with chrome plate and hardware.

52517-94 **\$59.95**
Fits Short Insert Style Sissy Bar Upright P/N 51513-02, 52737-94A or 52706-07.

C. BACKREST PADS

Sized to fit medallion and mini medallion-style sissy bar uprights. Pad mounts with single center screw and bolt-on mounting strap. Includes chrome-plated mounting hardware.

Fits Low Medallion Style Sissy Bar Upright P/N 52754-04 or 51851-09, Low Square Bar Mini-Medallion Style Sissy Bar Upright P/N 53282-06, Standard Square Bar Mini Medallion Style Sissy Bar Upright P/N 53281-06 or 53407-06, Standard Medallion Style Sissy Bar Upright P/N 52735-85, 53007-98, 52655-84, 52909-02 or 51517-02, Standard Bar & Shield Style Sissy Bar Upright 52739-83 or 51514-02, Standard Heritage Style Sissy Bar Upright P/N 52731-00 and Low Round Bar Sissy Bar Upright P/N 52300022 or 52300024.

1. 52652-04 Smooth. **\$69.95**
2. 52626-04 Smooth Top-Stitched. **\$69.95**



C. BACKREST PADS

D. BACKREST PADS

Sized to fit round bar sissy bar uprights, these pads mount to mini medallion style uprights with two mounting holes.

Fits Standard Round Bar Mini-Medallion Style Upright P/N 52877-10 or 51168-10. Also fits Low Round Bar Mini Medallion Style Sissy Bar Upright P/N 52540-09A, 51477-06, 54256-10, 52300049 and 52300050.

1. 51641-06 Smooth Top-Stitched. **\$69.95**
2. 51640-06 Smooth Bucket. **\$99.95**
3. 51622-07 Fat Boy® Lacing Bucket. **\$119.95**
4. 52300301 CVO™ FXSBSE Style – Black. **\$129.95**
5. 52300293 CVO FXSBSE Style – Brown. **\$129.95**
6. 52300336 '14 CVO FXSBSE Style. **\$129.95**

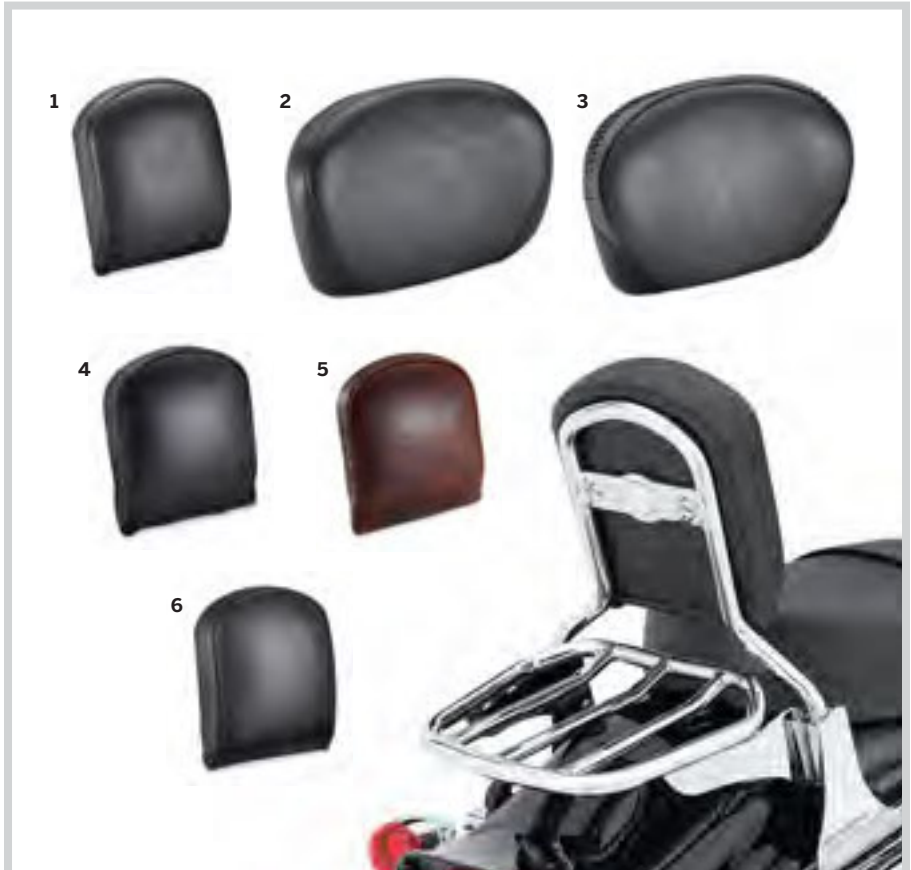

D. BACKREST PADS

Notice: The prices appearing in this catalog are the manufacturer's suggested retail prices. Actual retail prices may vary.



E. BACKREST PADS

E. BACKREST PADS

Sized to fit medallion and mini medallion-style sissy bar uprights. Pad mounts with single center screw and bolt-on mounting strap. Kit includes chrome-plated mounting hardware.

Fits Low Medallion Style Sissy Bar Upright P/N 52655-84, 52909-02, 52754-04, 51851-09, Standard Medallion Style Sissy Bar Upright P/N 52735-85 or 52877-08, Standard Square Bar Mini Medallion Style Sissy Bar Upright P/N 53281-06 or 53407-06, Standard Heritage Style Sissy Bar Upright P/N 52731-00 and Standard Round Bar Sissy Bar Upright P/N 52300018 or 52300020.

1. 52612-95	Smooth Top-Stitched.	\$69.95
2. 52412-79A	Embossed Bar & Shield Logo.	\$69.95
3. 52532-90	Fat Boy®.	\$79.95
4. 52348-97	Heritage Classic Bucket.	\$109.95
5. 52347-97	Fat Boy Bucket.	\$99.95
6. 51132-98	Smooth Bucket.	\$99.95

F. BACKREST PADS

Sized to fit tall medallion and insert-style sissy bar uprights. Pads mount with upper bolt-on mounting strap and two lower mounting clips. Kit includes chrome-plated mounting brackets and hardware.

Fits Tall Medallion Style Sissy Bar Upright P/N 52777-85A, 51519-02 or 52749-85A. Also fits Tall Insert Style Sissy Bar Upright P/N 51518-02 or 53552-81A.

52965-98	Smooth Top-Stitched.	\$79.95
-----------------	----------------------	----------------

G. PASSENGER BACKREST PAD

Styled to complement available touring and custom seats.

52631-07		\$69.95
-----------------	--	----------------

Fits One-Piece H-D® Detachables™ Sissy Bar Upright P/N 52729-08, 51853-07, 51849-07, 51146-10, 51161-10, 52300040, 52300042, 52300044 or 52300046.

H. CIRCULATOR BACKREST PAD

Keep comfortable on your next long ride. These breathable Circulator Backrest Pads feature 3D construction that promotes air movement and reduces heat build-up where the rider's body touches the backrest. Designed to keep the rider cool by reducing the perspiration build-up between you and the backrest surface, the Circulator Pad can be installed and removed in seconds for easy cleaning. Manufactured of UV-stable materials, these pads resist fading when exposed to the sun.

52300103	Wide Backrest Pad.	\$59.95
-----------------	--------------------	----------------

Fits wide profile rider and passenger backrest pads up to 12.0" wide and 9.0" tall.



F. BACKREST PADS



G. PASSENGER BACKREST PAD



H. CIRCULATOR BACKREST PAD

Notice: The prices appearing in this catalog are the manufacturer's suggested retail prices. Actual retail prices may vary.



162 DYNA®

Backrests & Racks

A. CUSTOM TAPERED SPORT LUGGAGE RACK*

Smooth sweeping curves and the brilliant chrome or gloss black finish define the look of this Sport Luggage Rack. Designed to complement both round and square bar Sissy Bar Uprights, this sleek rack adds a practical and stylish touch to the motorcycle.

Fits '04-later XL models equipped with H-D® Detachables™ Sideplates, '06-later Dyna® models (except FXDF, FXDFSE/2 and '10-later FXDWG) equipped with Rigid or Detachable Sideplates, '84-'05 Softail® models (except FXSTD and FLSTN) and '06-later FLST, FLSTC, FLSTNSE and FLSTSC models and '06 FLSTF models equipped with Detachable or Rigid Mount Sideplates.

50300030	Chrome.	\$139.95
50300031	Gloss Black.	\$139.95

Fits '10-later FXDF, FXDFSE2 and FXDWG models equipped with Rigid or H-D Detachables Sideplates and Sissy Bar Uprights.

54049-10	Gloss Black.	\$134.95
54055-10	Chrome.	\$134.95



A. CUSTOM TAPERED SPORT LUGGAGE RACK – CHROME



A. CUSTOM TAPERED SPORT LUGGAGE RACK – GLOSS BLACK

B. AIR FOIL PREMIUM LUGGAGE RACK*

The low-profile aerodynamic styling defines the look of this Luggage Rack. Available in mirror-chrome or rich gloss black finish, the die-cast rear "Air Foil" grabs your attention and the Bar & Shield insert adds a signature touch. The elegant round tube rack features inlaid rubber runners for added grip and dedicated bungee mounting points to simplify luggage tie-down. Kit includes all necessary mounting hardware. For added visibility, the rack is designed to incorporate the internal wiring of the Air Foil Rack LED Light Kit P/N 68000076 (red) or 68000077 (smoked) for a clean look.

Fits '04-later XL models equipped with H-D Detachables Sideplates, '06-later Dyna models (except FXDF, FXDFSE/2 and '10-later FXDWG) equipped with Rigid or Detachable Sideplates, '84-'05 Softail models (except FXSTD and FLSTN) and '06-later FLST, FLSTC, FLSTNSE and FLSTSC models and '06 FLSTF models equipped with Detachable or Rigid Mount Sideplates.

54290-11	Chrome.	\$209.95
54291-11	Gloss Black.	\$209.95



B. AIR FOIL PREMIUM LUGGAGE RACK – CHROME



B. AIR FOIL PREMIUM LUGGAGE RACK – GLOSS BLACK

C. LED LIGHT KIT

Custom fit to the Air Foil Luggage Rack, this fast-acting LED Light Kit operates as a supplemental rear running light and brake light. The high, center-mount position places the light in the line-of-sight of following vehicles and the bright, fast-acting LED lamps get you noticed. Wiring is concealed inside the rack tubes for a clean, custom installation. Available with red or smoked lens.

Fits Air Foil Luggage Rack P/N 54290-11, 54291-11 and Air Wing Sissy Bar Upright P/N 52300146 and 52300147. Installation requires separate purchase of model-specific Wiring Harness Kit.

68000076	Red Lens.	\$44.95
68000077	Smoked Lens.	\$44.95

Also available:

LED LIGHT KIT WIRING HARNESS

Required for installation of LED Light Kit on Air Foil Luggage Rack P/N 54290-11 or 54291-11.

73415-11		\$11.95
-----------------	--	----------------

Fits '06-later Dyna models (except FXDF, FXDFSE/2, '14-later FXDL and '10-later FXDWG), '84-'05 Softail models (except FXSTD and FLSTN), '06-later FLST, FLSTC and FLSTSC models and '06 FLSTF models with Air Foil Luggage LED Light Kit P/N 68000076 or 68000077.



C. LED LIGHT KIT – RED LENS



***WARNING:** Do not use this rack as a seat. Do not exceed the fender rack weight capacity. Using as seat or exceeding this capacity could cause handling problems which could result in loss of control and death or serious injury.

Notice: The prices appearing in this catalog are the manufacturer's suggested retail prices. Actual retail prices may vary.

DYNA® 163

Backrests & Racks



D. TAPERED LUGGAGE RACK – CHROME



D. TAPERED LUGGAGE RACK – GLOSS BLACK

D. TAPERED LUGGAGE RACK*

Styled to enhance the lines of the motorcycle, this sleek, compact Tapered Rack is an elegant solution for carrying your lunch to work or your luggage across the country.

Fits '04-later XL models equipped with H-D® Detachables™ Sideplates, '06-later Dyna® models (except FXDF, FXDFSE/2 and '10-later FXDWG) equipped with Rigid or Detachable Sideplates, '84-'05 Softail® models (except FXSTD and FLSTN) and '06-later FLST, FLSTC, FLSTNSE and FLSTSC models and '06 FLSTF models equipped with Detachable or Rigid Mount Sideplates.

53718-04	Chrome.	\$119.95
53510-07	Gloss Black.	\$119.95

E. SPORT LUGGAGE RACK – FOUR BAR*

This sleek rack complements the lines of your motorcycle. Can be used with H-D® Detachables™ or Rigid Mount Sissy Bar Sideplates.

53899-02 Chrome. **\$119.95**

Fits '04-later XL models equipped with Rigid Sideplates P/N 53925-04 and '02-'05 Dyna models equipped with Rigid Sideplates or Detachable Sideplates.

53711-96A Chrome. **\$119.95**

Fits '90-'03 XL models with H-D Detachables Sideplate Kit P/N 53545-95, '82-'03 XL models with Rigid Mount Sideplate Kit P/N 52806-94B or 52782-82B; '82-'94 FXR models with Rigid Sideplate Kit P/N 52781-82B (except FXRS-CONV. and FXRT). Fits '96-'01 Dyna models (except FXDWG). All '96-'01 Dyna models equipped with Rigid Mount Sideplates require the separate purchase of Luggage Rack Adapter Kit P/N 53828-00. Also fits '99-'00 FXR models.



E. SPORT LUGGAGE RACK – FOUR BAR



F. SPORT LUGGAGE RACK – FIVE BAR

F. SPORT LUGGAGE RACK – FIVE BAR*

This rack brings touring flexibility to your motorcycle. Can be used with H-D Detachables or Rigid Mount Sissy Bar Sideplates.

53862-00 Chrome. **\$139.95**

Fits '04-later XL models equipped with Detachable Sideplates, '06-later Dyna models (except FXDF, FXDFSE/2 and '10-later FXDWG) equipped with Rigid or Detachable Sideplates, '84-'05 Softail models (except FXSTD and FLSTN), '06-later FLST, FLSTC and FLSTSC models and '06 FLSTF models equipped with Rigid or Detachable Sideplates. Does not fit with Round Bar Uprights P/N 52300018, 52300020, 52300022 and 52300024.

G. CHOPPED FENDER LUGGAGE RACK*

This Luggage Rack is the ideal option for your ride across town or across the state. Designed for the chopped rear fender, this simple rack adds practical luggage space without compromising style. Rear supports attach to the fender struts and the rack is secured to the passenger pillion mounting point on the rear fender. Available in your choice of chrome or gloss black finish, this rack is compatible with the Original Equipment short upright or H-D Detachables uprights and docking hardware.

Fits '10-later FXDWG models.

54252-10	Gloss Black.	\$144.95
50300038	Chrome.	\$144.95



G. CHOPPED FENDER LUGGAGE RACK – CHROME



G. CHOPPED FENDER LUGGAGE RACK – GLOSS BLACK



***WARNING:** Do not use this rack as a seat. Do not exceed the fender rack weight capacity. Using as seat or exceeding this capacity could cause handling problems which could result in loss of control and death or serious injury.

Notice: The prices appearing in this catalog are the manufacturer's suggested retail prices. Actual retail prices may vary.

164 DYNA®

Backrests & Racks

A. BOBTAIL FENDER RACK*

Style and function come together in this beautifully sculpted luggage rack. The sweeping rails and the narrow cross tubing combine to form a rack that follows the contour and enhances the shape of the bobtail fender. And because the rack floats above the fender, you have a convenient spot to secure a duffel bag or touring luggage without risking damage to the painted surface.

Fits '08-'13 FXDF and '06-'08 FXDWG models. Does not fit FXDFSE/2. Does not fit with Tri-Bar LED Tail Light Kit P/N 68546-09.

56802-06A	Chrome.	\$99.95
50300036	Gloss Black.	\$99.95



A. BOBTAIL FENDER RACK – CHROME



A. BOBTAIL FENDER RACK – GLOSS BLACK

B. H-D® DETACHABLES™ SOLO RACK*

Add touring capabilities to your solo seat Dyna® model in less than 60 seconds. This detachable Solo Rack fits over the fender when the passenger pillion is removed. The rack features a hand-polished and chrome-plated finish to add a stylish flair. Requires Docking Hardware.

53511-06 Chrome. **\$199.95**
 Fits '06-later Dyna models (except FLD, FXDF, FXDFSE/2 '10-later FXDWG or '13-later FXDB HDI and India configuration) equipped with solo seat. Requires separate purchase of appropriate Detachable Docking Hardware. '13-later FXDB models equipped with a side-mount license plate require License Plate Relocation Kit P/N 67900130.



B. H-D DETACHABLES SOLO RACK



C. RIGID SOLO RACK

C. RIGID SOLO RACK*

Versatile rigid-mount Solo Luggage Rack features a rich gloss black finish that complements almost any paint color. Equip the contoured rack with a duffel bag for a cross-country solo ride or attach the available H-D® Detachables™ Passenger Pillion P/N 52689-09 for a comfortable two-up tour.

52796-09 Gloss Black. **\$159.95**
 Fits '06-later Dyna models with solo seats (except FLD, FXDF, FXDL, FXDFSE/2 and '10-later FXDWG).

D. REAR DOCKING HARDWARE COVER KIT

Disguise the rear docking hardware with these easy-to-install covers. The caps slide over the exposed docking points and are held in place by a strong magnetic pull. The caps are easy to remove when you wish to reinstall detachable accessories. Covers are available with brilliant chrome or durable gloss black finish to match your bike's attitude. Sold in pairs.

Fits many accessory docking hardware kits. Refer to the fitment matrix in this P&A Catalog page 573 or the Parts & Accessories section of www.harley-davidson.com for details.

48218-10	Short Chrome (pair).	\$34.95
48220-10	Large Chrome (pair).	\$34.95
48035-09	Small Chrome (pair).	\$34.95
48221-10	Short Black (pair).	\$34.95
48223-10	Large Black (pair).	\$34.95
48225-10	Small Black (pair).	\$34.95



D. REAR DOCKING HARDWARE COVER KIT – CHROME



D. REAR DOCKING HARDWARE COVER KIT – GLOSS BLACK



***WARNING:** Do not use this rack as a seat. Do not exceed the fender rack weight capacity. Using as seat or exceeding this capacity could cause handling problems which could result in loss of control and death or serious injury.

Notice: The prices appearing in this catalog are the manufacturer's suggested retail prices. Actual retail prices may vary.

DYNA® 165

Saddlebags & Luggage

E. H-D® DETACHABLES™ LEATHER SADDLEBAGS FOR DYNA® MODELS

These large capacity detachable saddlebags are completely removable with the simple pull of the internal handle, leaving your bike clean and ready to cruise the boulevard. The handsome leather bags feature hidden quick-release clips behind the traditional strap and buckle. When removed, the large capacity bags leave behind two simple, inconspicuous docking points. The bags are compatible with both rigid and H-D® Detachables™ accessories when installed with the appropriate docking hardware kits. Luggage capacity: 2400 cubic inches total.

90181-08A **\$949.95**
 Fits '06-later Dyna® models (except FLD). '09-later FXDB models require separate purchase of Turn Signal Relocation Kit P/N 68227-09. '10-later FXDWG models require separate purchase of Turn Signal Relocation Kit P/N 68544-10. All other models (except FXDF and '06-'08 FXDWG) require separate purchase of Turn Signal Relocation Kit P/N 68732-02A (Domestic), P/N 68733-02A (International) or Layback License Plate Kit P/N 60215-06. Does not fit with Rear Axle Covers or Premium Profile Low Suspension Kit P/N 54619-08.

Also available:

TURN SIGNAL RELOCATION KIT

Required for installation of rigid mounted saddlebags and detachable accessories on '09-later FXDB models.

68227-09 Fits '09-later FXDB models. **\$109.95**

TURN SIGNAL RELOCATION KIT

Kit moves turn signals from rear fender struts to a license bracket-mounted turn signal bar.

Required to install Saddlebags P/N 91615-09A, 88200-09A, 90181-08A, 90460-06B, 79300-06A, 90564-06B, 90369-06C and 88343-10. Fits '02-later Dyna models (except FXDWG, FXDF and '09-later FXDB) and '04-later XL models (except XL883N, XL1200N, XL1200X and '11-later XL1200C). Does not fit with Layback License Plate Mounting Kits.

68732-02A Domestic. **\$89.95**

68733-02A International. **\$89.95**

TURN SIGNAL RELOCATION KIT

Kit moves turn signals from rear fender struts to a license bracket-mounted turn signal bar.

Required to install Saddlebags P/N 79078-02, 79300-04B and 91622-03.

68718-02 Fits '02-'05 FXDWG models. **\$39.95**

DYNA LICENSE PLATE/TURN SIGNAL RELOCATION KIT

Required for installation of Saddlebags.

68544-10 **\$249.95**
 Fits '10-later FXDWG models equipped with saddlebags.

LICENSE PLATE RELOCATION KIT

Required for installation of available saddlebags and/or detachable sissy bars on '13-later FXDB models equipped with side-mount license plate. Kit replaces Original Equipment side-mount license plate.

67900130 **\$134.95**

Fits '13-later FXDB models equipped with side-mount license plate.



E. H-D DETACHABLES LEATHER SADDLEBAGS FOR DYNA MODELS



STEP 1

Equipped with large capacity saddlebags, your bike is ready to take on the longest journey.



STEP 2

Pull and turn the hidden cam lock to release the bags from the docking hardware.



STEP 3

Slide the bag rearward to disengage the mounting bracket and lift the bags away.



STEP 4

You are left with a stripped-down cruiser, ready to prowl the streets.

NOTE: Some Harley-Davidson® saddlebags are made of leather. Fine leathers or other natural materials WILL gain "character," such as wrinkles or wear, with age. This is normal. A fine, aged patina and character wrinkles are a sign of the extremely high quality materials used to construct your saddlebags. The appearance of scars or marks on the leather are a result of using natural leather panels and should not be thought of as an imperfection. Please use Harley-Davidson Leather Protectant P/N 93600034 to protect your investment.

Notice: The prices appearing in this catalog are the manufacturer's suggested retail prices. Actual retail prices may vary.

DYNA

166 DYNA®

Saddlebags & Luggage

A. RIGID LOCKING LEATHER SADDLEBAGS

These saddlebags combine a premium leather finish with extra-durable construction. The hard-shell design is covered in leather for a traditional look, while the locking hinged lids offer modern convenience and security. Styled to complement the sleek, narrow Dyna® profile, these bags offer plenty of storage for a trip across town or across the country. Kit includes reflectors. Luggage capacity: 2400 cubic inches total.

91615-09A **\$729.95**

Fits '02-later Dyna models (except FLD, '02-'05 FXDWG and '09-later FXDBP with optional chrome or black strut covers). '02-'05 models require separate purchase of Mounting Hardware Kit P/N 92025-09. '10-later FXDWG models require separate purchase of Turn Signal Relocation Kit P/N 68544-10. '09-later FXDB models require separate purchase of Turn Signal Relocation Kit P/N 68227-09. '13-later FXDB models equipped with side-mount license plate requires License Plate Relocation Kit P/N 67900130. All other years and models (except FXDF and FXDWG) require separate purchase of Turn Signal Relocation Kit P/N 68732-02A (Domestic), 68733-02A (International) or Layback License Plate Kit P/N 60215-06. Not for use with Rear Axle Covers on FXDF and FXDWG models.



A. RIGID LOCKING LEATHER SADDLEBAGS

B. BROWN DISTRESSED LEATHER SADDLEBAGS

A vintage look for a modern ride. These large capacity saddlebags are dressed in brown distressed leather for a timeless appearance. The raw edging and untreated leather surfaces will age and weather for a warm, comfortable feel, but the rigid-back construction will help the bag hold its shape. Dark metal snaps and an embossed Bar & Shield logo continue the bomber jacket look. Luggage capacity: 2380 cubic inches total.

88348-10 **\$629.95**

Fits '02-later Dyna models (except FLD, '02-'05 FXDWG and '09-later FXDBP with optional chrome or black strut covers). '02-'05 models require separate purchase of Mounting Hardware Kit P/N 92025-09. '09-later FXDB models require separate purchase of Turn Signal Relocation Kit P/N 68227-09. '10-later FXDWG models require separate purchase of Turn Signal Relocation Kit P/N 68544-10. '13-later FXDB models equipped with side-mount license plate requires License Plate Relocation Kit P/N 67900130. All other years and models (except FXDF and FXDWG) require separate purchase of Turn Signal Relocation Kit P/N 68732-02A (Domestic), 68733-02A (International) or Layback License Plate Kit P/N 60215-06. Not for use with Rear Axle Covers on FXDF and FXDWG models.



B. BROWN DISTRESSED LEATHER SADDLEBAGS

C. BLACK DISTRESSED LEATHER SADDLEBAGS

Step over to the dark side. Distressed black leather with hints of coffee brown and aged buckles provide a weathered, "anti-chrome" look to your blacked-out ride. The riveted Dark Custom™ logo patch on the rear of each bag completes the edgy, tradition-breaking appearance. Luggage capacity: 2380 cubic inches total.

88200-09A **\$629.95**

Fits '02-later Dyna models (except FLD, '02-'05 FXDWG and '09-later FXDBP with optional chrome or black strut covers). '02-'05 models require separate purchase of Mounting Hardware Kit P/N 92025-09. '09-later FXDB models require separate purchase of Turn Signal Relocation Kit P/N 68227-09. '10-later FXDWG models require separate purchase of Turn Signal Relocation Kit P/N 68544-10. '13-later FXDB models equipped with side-mount license plate requires License Plate Relocation Kit P/N 67900130. All other years and models (except FXDF and FXDWG) require separate purchase of Turn Signal Relocation Kit P/N 68732-02A (Domestic), 68733-02A (International) or Layback License Plate Kit P/N 60215-06. Not for use with Rear Axle Covers on FXDF and FXDWG models.



C. BLACK DISTRESSED LEATHER SADDLEBAGS

NOTE: Some Harley-Davidson® saddlebags are made of leather. Fine leathers or other natural materials WILL gain "character," such as wrinkles or wear, with age. This is normal. A fine, aged patina and character wrinkles are a sign of the extremely high quality materials used to construct your saddlebags. The appearance of scars or marks on the leather are a result of using natural leather panels and should not be thought of as an imperfection. Please use Harley-Davidson Leather Protectant P/N 93600034 to protect your investment.

Notice: The prices appearing in this catalog are the manufacturer's suggested retail prices. Actual retail prices may vary.



D. LEATHER SADDLEBAGS FOR DYNA MODELS

D. LEATHER SADDLEBAGS FOR DYNA® MODELS

These genuine leather saddlebags deliver style and large capacity all in one. Constructed around a rigid plastic tub for long term durability, the leather bag features a stylish design with lines that enhance the smooth Dyna® model profile. The leather saddlebags provide custom looks and tons of storage space for the road. Hidden quick-release closures add packing convenience. Luggage capacity: 2380 cubic inches total.

90369-06D \$629.95

Fits '02-later Dyna models (except FLD, '02-'05 FXDWG and '09-later FXDBP with optional chrome or black strut covers). '02-'05 models require separate purchase of Mounting Hardware Kit P/N 92025-09. '09-later FXDB models require separate purchase of Turn Signal Relocation Kit P/N 68227-09. '10-later FXDWG models require separate purchase of Turn Signal Relocation Kit P/N 68544-10. '13-later FXDB models equipped with side-mount license plate requires License Plate Relocation Kit P/N 67900130. All other years and models (except FXDF and FXDWG) require separate purchase of Turn Signal Relocation Kit P/N 68732-02A (Domestic), 68733-02A (International) or Layback License Plate Kit P/N 60215-06. Not for use with Rear Axle Covers on FXDF and FXDWG models.

E. LEATHER SADDLEBAGS FOR DYNA MODELS

Styled with sweeping lines to complement the Dyna fender, these bags feature plenty of storage space for a ride to the store or to Sturgis. The rigid plastic tub, wrapped in genuine leather, offers long-term durability. The traditional leather straps hide quick-disconnect closures for packing convenience. Luggage capacity: 2380 cubic inches total.

79300-06D \$629.95

Fits '02-later Dyna models (except FLD, '02-'05 FXDWG and '09-later FXDBP with optional chrome or black strut covers). '02-'05 models require separate purchase of Mounting Hardware Kit P/N 92025-09. '09-later FXDB models require separate purchase of Turn Signal Relocation Kit P/N 68227-09. '10-later FXDWG models require separate purchase of Turn Signal Relocation Kit P/N 68544-10. '13-later FXDB models equipped with side-mount license plate requires License Plate Relocation Kit P/N 67900130. All other years and models (except FXDF and FXDWG) require separate purchase of Turn Signal Relocation Kit P/N 68732-02A (Domestic), 68733-02A (International) or Layback License Plate Kit P/N 60215-06. Not for use with Rear Axle Covers on FXDF and FXDWG models.

F. SYNTHETIC LEATHER SADDLEBAGS

These synthetic leather saddlebags deliver both style and large capacity at a low cost. The rigid plastic tub is wrapped in synthetic leather for long-term durability. The bag features a large protective lid with hook-and-loop and snap closure and an inner pocket for small item storage. Luggage capacity: 2380 cubic inches total.

90564-06D \$479.95

Fits '02-later Dyna models (except FLD, '02-'05 FXDWG and '09-later FXDBP with optional chrome or black strut covers). '02-'05 models require separate purchase of Mounting Hardware Kit P/N 92025-09. '09-later FXDB models require separate purchase of Turn Signal Relocation Kit P/N 68227-09. '10-later FXDWG models require separate purchase of Turn Signal Relocation Kit P/N 68544-10. '13-later FXDB models equipped with side-mount license plate requires License Plate Relocation Kit P/N 67900130. All other years and models (except FXDF and FXDWG) require separate purchase of Turn Signal Relocation Kit P/N 68732-02A (Domestic), 68733-02A (International) or Layback License Plate Kit P/N 60215-06. Not for use with Rear Axle Covers on FXDF and FXDWG models.



E. LEATHER SADDLEBAGS FOR DYNA MODELS



F. SYNTHETIC LEATHER SADDLEBAGS

NOTE: Some Harley-Davidson® saddlebags are made of leather. Fine leathers or other natural materials WILL gain "character," such as wrinkles or wear, with age. This is normal. A fine, aged patina and character wrinkles are a sign of the extremely high quality materials used to construct your saddlebags. The appearance of scars or marks on the leather are a result of using natural leather panels and should not be thought of as an imperfection. Please use Harley-Davidson Leather Protectant P/N 93600034 to protect your investment.

Notice: The prices appearing in this catalog are the manufacturer's suggested retail prices. Actual retail prices may vary.

168 DYNA®

Saddlebags & Luggage

A. HARD SADDLEBAGS*

The Dyna® models are designed to devour miles and these bags add to the appetite. These Hard Saddlebags are lockable and provide secure storage for the road. Using injection-molded construction, these bags offer a fresh, alternative look as compared with their leather cousins. Kit includes Turn Signal Relocation Hardware. Luggage capacity: 2,500 cubic inches total.

Fits '96-later Dyna models (except FXDS-CONV., '00-'03 FXDX, FXDXT, '09-later FXDB, '10-later FXDWG and '12-later FLD). Fits with H-D® Detachables™ or Rigid-Mounted Sissy Bars and Luggage Racks. (Will not fit FXDWG or FXDF models equipped with detachable sideplates.)

90126-00A	Primed.	\$1,249.95
90126-00DH	Vivid Black.	\$1,549.95



A. HARD SADDLEBAGS – (VIVID BLACK SHOWN)

B. SINGLE-SIDED SWINGARM BAG

Less is more. With enough room for the essentials, these stylish Swingarm Bags eliminate the need to stuff your pockets or bungee a bag across the passenger pillion. Shaped to hug the contour of your bike's frame, these compact bags add an old school look. Bags are constructed of heavyweight leather and feature a pouch-style flap lid that is secured with two quick-disconnect clips that are hidden behind traditional straps and buckles. The semirigid-backed bag is secured to the left side of the bike with easy-to-install brackets and adjustable straps. Bag is available in your choice of rich black leather or brown distressed leather finish. Luggage capacity: 265 cubic inches total.

Fits '06-later Dyna models (except FLD) equipped with Solo Seats. Requires removal of passenger pegs.

90200570	Black Leather.	\$179.95
90200571	Brown Distressed Leather.	\$179.95



B. SINGLE-SIDED SWINGARM BAG – BLACK LEATHER



B. SINGLE-SIDED SWINGARM BAG – BROWN DISTRESSED LEATHER

C. LEATHER THROW-OVER SADDLEBAGS

These traditional Leather Throw-Over Bags feature large side gussets for increased capacity and full-length straps with hidden quick-disconnect clips for easy access.

91008-82C	\$369.95
------------------	-----------------

Fits '82-later XL (except XL1200T), '08-later Dyna (except FLD) and '84-'99 Softail® models equipped with H-D® Chrome Saddlebag Supports.



C. LEATHER THROW-OVER SADDLEBAG

D. SYNTHETIC LEATHER THROW-OVER SADDLEBAGS

Synthetic leather with embossed "Eagle Wing" logo. 11.0" W x 10.0" T x 3.75" D.

90570-86TA	\$119.95
-------------------	-----------------

Fits '82-'03 XL, '91-'05 Dyna and '84-'99 Softail models equipped with saddlebag supports.



D. SYNTHETIC LEATHER THROW-OVER SADDLEBAGS

*NOTE: This product is a "Paint to Order" accessory. Please allow for an average of 5 weeks delivery for this item.

Notice: The prices appearing in this catalog are the manufacturer's suggested retail prices. Actual retail prices may vary.



E. CHROME SADDLEBAG SUPPORTS



**F. SADDLEBAG TRAVEL-PAKS
(91959-97 SHOWN)**



**G. DOWN-TUBE BAG –
BLACK LEATHER**



**G. DOWN-TUBE BAG –
BROWN DISTRESSED LEATHER**



H. UNIVERSAL SADDLEBAG LOCK KIT



**I. AUXILIARY POWER PORT –
SADDLEBAG MOUNT**



J. USB CHARGING ADAPTOR

E. CHROME SADDLEBAG SUPPORTS

Fits with or without Sissy Bar Uprights, attach easily and protect bags from contacting brake and swingarm.

90589-91D \$149.95

Fits '91-'05 Dyna® models (except '93-'95 FXDWG). Also fits '96-'05 FXDWG models. '02-'08 Dyna models require separate purchase of (2) Bullet Turn Signals P/N 68425-01 (Domestic) or 68420-01 (International). '00-'01 FXDX models require the separate purchase of Hardware Kit P/N 90272-00. Does not fit with H-D® Detachables™ sissy bars or racks.

91017-10 \$155.95

Fits '08-later Dyna models (except FLD). Does not fit with H-D Detachables sissy bars or racks.

F. SADDLEBAG TRAVEL-PAKS

Water-resistant liners make packing easy. Feature inner pockets for extra storage and an embroidered Bar & Shield logo.

91959-97 \$54.95

Liner dimensions: 12.0" W x 10.0" T x 5.0" D.

91486-01 \$49.95

Fits XL and Dyna models equipped with Color-Matched Hard Saddlebags.

G. DOWN-TUBE BAG

The perfect place to store a couple of tools, a tire gauge or your disc lock. The rigid-backed bag features a stylish heavy leather flap and traditional strap-and-buckle closures to provide both function and flair. Easy-to-install, the low frame placement is inconspicuous, but still provides quick access when needed. Kit includes all required mounting hardware.

Fits '04-later XL, XR and '06-later Dyna models (except FLD). Does not fit XL models with engine guard. Does not fit XL models with Boom!™ Audio Cruiser Amp and Speaker Kit P/N 76262-08 or 76320-08. Does not fit Dyna models with evaporative emissions canister (California and AP markets). Does not fit with Dyna Oil Cooler Kit P/N 26151-07. Does not fit XL and Dyna models equipped with Front Spoilers, FXDSE/2 and FXDFSE/2 models require removal of Original Equipment front spoiler.

93300044 Black Leather. \$129.95

93300045 Brown Distressed Leather. \$129.95

H. UNIVERSAL SADDLEBAG LOCK KIT

Keep the contents of your existing soft-sided saddlebags safe from the grab-and-go thief. This unique kit features two extra-small barrel locks that can replace existing saddlebag snaps to perform double duty as locks or as snaps when you don't need to lock your bags. Can be keyed to match your barrel-style ignition key. Sold in pairs.

Fits most soft-sided leather and vinyl saddlebags. Does not fit FLHRC and FLHRS.

90300003 Keyed To Match. \$59.95

90300017 Random Key Code. \$49.95

I. AUXILIARY POWER PORT – SADDLEBAG MOUNT

Charge your cell phone or portable music player from this handy saddlebag-mounted 12-volt power port. Conventional "cigarette lighter" style power outlet accepts most 12V automotive power adaptor plugs and features a flip-top cover to protect the port while not in use.

69200091 \$40.95

Fits models equipped with 12-volt battery. Does not fit VRSC™ models, Throw-Over or Swingarm Bags. Not for use with accessory Fitted Liners or Premier Liners. Requires separate purchase of Battery Charging Harness P/N 94624-97B, if not already equipped.

J. USB CHARGING ADAPTOR

Charge your cell phone, MP3 players and other hand-held devices while on the road. Compact Adaptor plugs into standard or accessory 12-volt power ports and provides a standard USB-style outlet that accepts many phone and music player power cords.

69200357 \$19.95

For use with 12V Auxiliary Power Port.

170 DYNA®

Fuel Tank Trim

A. BROWN DISTRESSED LEATHER TANK PANEL

Styled to complement Brown Distressed Leather seats and saddlebags, this tank panel is the perfect choice to complete your vintage western saddle look. Easy-to-install panel features an embossed Bar & Shield logo.

70900103 **\$59.95**

Fits '00-later Softail® models (except FXCW, FXCWC, FXS, FXSB, FXSBSE, FXSTD, FXSTSSE/2/3, FLS, FLSTFSE2, FLSTNSE, FLSTSB, FLSTSE/2/3 and '09-later FLSTC). Also fits '93-'08 FXDWG, '06 FXD35 and '07-later FXDF and FXDC models. '93-'03 FXDWG models require the separate purchase of Clip P/N 10102 and O-Ring P/N 11174.



A. BROWN DISTRESSED LEATHER TANK PANEL

B. PREMIUM TANK PANEL WITH POUCH

This leather tank panel features an over-sized pouch for convenient "at your fingertips" storage. The heavy-duty leather pouch will maintain its shape for miles to come while the bold chrome Bar & Shield medallion sits proudly on the flap for all to admire.

91135-09 **\$99.95**

Fits '00-later Softail models (except FXCW, FXCWC, FXS, FXSB, FXSBSE, FXSTD, FXSTSSE/2/3, FLS, FLSTFSE2, FLSTNSE, FLSTSB, FLSTSE/2/3 and '09-later FLSTC). Also fits '93-'08 FXDWG, '06 FXD35 and '07-later FXDF and FXDC models. '93-'03 FXDWG models require the separate purchase of Clip P/N 10102 and O-Ring P/N 11174.



B. PREMIUM TANK PANEL WITH POUCH

C. LEATHER TANK PANEL WITH TEARDROP CONCHO AND POUCH

Stylish leather tank panel puts a convenient storage pouch right at your fingertips. Embossed basket-weave pattern and bright chrome teardrop concho matches the Softail Springer™ Classic trim and complements other smooth leather and vinyl seats and bags.

91469-06 **\$99.95**

Fits '00-later Softail models (except FXCW, FXCWC, FXS, FXSB, FXSBSE, FXSTD, FXSTSSE/2/3, FLS, FLSTFSE2, FLSTNSE, FLSTSB, FLSTSE/2/3 and '09-later FLSTC). Also fits '93-'08 FXDWG, '06 FXD35 and '07-later FXDF and FXDC models. '93-'03 FXDWG models require the separate purchase of Clip P/N 10102 and O-Ring P/N 11174.



C. LEATHER TANK PANEL WITH TEARDROP CONCHO AND POUCH

D. LEATHER TANK PANEL WITH POUCH

Leather tank panels feature an integrated storage pouch, perfect for those small items you like to keep handy. Constructed of tough steerhide over a rigid, molded base.

Fits '93-'03 FXDWG and '00-later Softail models (except FXCW, FXCWC, FXS, FXSB, FXSBSE, FXSTD, FXSTSSE/2/3, FLS, FLSTFSE2, FLSTNSE, FLSTSB, FLSTSE/2/3 and '09-later FLSTC).

91409-00 Braided Trim & Concho. **\$99.95**

91407-00 Chrome Studs & Concho. **\$99.95**

91408-00 Braided Flap & Concho. **\$99.95**



D. LEATHER TANK PANEL WITH POUCH – BRAIDED TRIM AND CONCHO



D. LEATHER TANK PANEL WITH POUCH – CHROME STUDS AND CONCHO

E. LEATHER TANK PANEL WITH EMBOSSED SKULL LOGO

Add a little menace to your bike with this skull-embossed leather tank panel.

91001-01 **\$49.95**

Fits '93-'03 FXDWG and '00-later Softail models (except FXCW, FXCWC, FXS, FXSB, FXSBSE, FXSTD, FXSTSSE/2/3, FLS, FLSTFSE2, FLSTNSE, FLSTSB, FLSTSE/2/3 and '09-later FLSTC).



D. LEATHER TANK PANEL WITH POUCH – BRAIDED FLAP AND CONCHO



E. LEATHER TANK PANEL WITH EMBOSSED SKULL LOGO

Notice: The prices appearing in this catalog are the manufacturer's suggested retail prices. Actual retail prices may vary.



F. DASH PANEL EXTENSION – CHROME
(71282-04 SHOWN)



F. DASH PANEL EXTENSION – CHROME
(71284-01 SHOWN)

F. DASH PANEL EXTENSION – CHROME

Stretch the lines of your chrome dash panel the full length of the fuel tank. This chrome-plated trim kit continues the lines and finishes of your standard tank panel to the front of the seat. The curving lines and Bar & Shield logo add a custom touch without the expense of a custom tank.

71282-04 **\$42.95**
Fits '04-'08 FXDWG, '06 FXD35, '07-'11 FXDC and '08-'13 FXDF models.

71284-01 Fits '95-'03 FXDWG models. **\$41.95**

G. CONSOLE KIT – CHROME

Replace the wrinkle black console with a sweep of chrome. Manufactured to Original Equipment specifications, this mirror-chrome dash panel fits like a glove around the stock fuel cap and fuel gauge. Kit includes chrome-plated stainless steel mounting hardware.

67188-04 **\$149.95**
Fits '04-'10 FXD, FXDX and '04-'06 FXDC models.

H. CONSOLE KIT FOR DYNA® LOW RIDER® MODELS – CHROME

Replace the standard black console with a sweep of chrome. Manufactured to Original Equipment specifications, this mirror-chrome dash panel fits like a glove around the stock speedometer and tachometer gauges. Kit includes chrome-plated stainless steel mounting hardware.

67187-04 Fits '04-'09 FXDL models. **\$174.95**

I. INSTRUMENT HOUSING AND FUEL TANK TRIM PANEL – CHROME

Give the custom look of chrome to the fuel tank on Dyna® Low Rider® models. (Instrument housing and trim panel sold separately.)

1. Instrument Housing
67189-95 Fits '95-'03 FXDL models. **\$99.95**

2. Chrome Fuel Tank Trim Panel
61655-91 Fits '91-'03 FXDL models. **\$149.95**



G. CONSOLE KIT – CHROME



I. INSTRUMENT HOUSING AND FUEL TANK TRIM PANEL – CHROME



H. CONSOLE KIT FOR DYNA LOW RIDER MODELS – CHROME



Notice: The prices appearing in this catalog are the manufacturer's suggested retail prices. Actual retail prices may vary.

172 DYNA®

Chassis Trim

A. COIL COVER – CHROME

This sleek, Chrome Coil Cover features an innovative design that conceals all the mounting hardware. It offers a great, easy way to customize a very visible part of your Dyna® motorcycles.

31709-04 **\$39.95**
Fits '04-later fuel-injected Dyna models.

B. BAR & SHIELD LOGO COIL COVER

Featuring a radical open-face design with a Bar & Shield silhouette, this Chrome Coil Cover matches the Chrome Voltage Regulator Cover for an integrated custom look. Includes all mounting hardware.

74616-04 **\$39.95**
Fits '01-later EFI equipped Softail® models (except FXCW, FXCWC, FXS, FXSB, FXSBSE and FXST-Aus) and '04-later EFI equipped Dyna models.

C. VOLTAGE REGULATOR COVER

Designed for up-front style, the open face and floating Bar & Shield logo on this chrome cover provide good looks without compromising air flow across the voltage regulator. Kit includes chrome-plated mounting hardware.

74667-06 **\$44.95**
Fits '06-'11 Dyna models.

74665-04 **\$44.95**
Fits '04-'05 FXDL and FXDWG models.

D. VOLTAGE REGULATOR COVER

With looks that create their own electricity, this chrome-plated cover features an embossed Bar & Shield logo and an open-center grill that allows air to flow through for regulator cooling. Designed for easy installation. Chrome mounting hardware included.

74577-97 **\$44.95**
Fits '91-'03 Dyna models.

E. BATTERY & ELECTRICAL PANEL COVER KIT – CHROME

Dress your bike with a new chrome skin. This two-piece kit replaces the painted battery and electrical panel covers and adds a bright contrast to the motorcycle's profile. Add your choice of accessory Battery Cover Band Trim (sold separately) for a finishing touch.

61300186 **\$159.95**
Fits '12-later Dyna models.

F. ELECTRICAL PANEL TRIM – CHROME

This sweeping chrome spear adds a mirror-polished accent to your bike's profile. The easy-to-install band is a high-contrast addition to the Original Equipment painted electrical panel cover or the perfect finishing touch on a Chrome Cover.

66462-07 **\$44.95**
Fits '04-later Dyna models (except FXDL, '06 FXD35 and '04-'08 FXDWG models with Original Equipment electrical panel cover).

G. ELECTRICAL PANEL COVER WITH TRIM – CHROME

Chrome-plated Electrical Panel Cover with concealed mounting hardware provides a nice clean look. Kit includes panel cover, distinctive chrome-plated die-cast trim with black accented lines and Bar & Shield logo and all necessary mounting hardware.

66426-04 **\$84.95**
Fits '04-'11 Dyna models.



A. COIL COVER – CHROME



B. BAR & SHIELD LOGO COIL COVER



C. VOLTAGE REGULATOR COVER



D. VOLTAGE REGULATOR COVER



E. BATTERY & ELECTRICAL PANEL COVER KIT – CHROME



F. ELECTRICAL PANEL TRIM – CHROME



G. ELECTRICAL PANEL COVER WITH TRIM – CHROME

Notice: The prices appearing in this catalog are the manufacturer's suggested retail prices. Actual retail prices may vary.



H. BATTERY COVER – CHROME



I. BATTERY COVER BAND – CHROME



J. BATTERY COVER BAND – “HARLEY-DAVIDSON” SCRIPT



K. BATTERY COVER BAND – SKULL



L. BATTERY COVER



M. BATTERY SIDE COVER – CHROME



N. CHROME BATTERY COVERS



O. CHROME BATTERY TOP COVER

H. BATTERY COVER – CHROME

Dress your battery with a new chrome skin. This one-piece Chrome Battery Cover replaces the painted box and adds a bright contrast to the Original Equipment satin aluminum trim band.

66375-06 **\$79.95**
Fits '06-later Dyna® models. '14-later Dyna models require purchase of a battery cover trim band.

I. BATTERY COVER BAND – CHROME

This sweeping chrome band replaces the Original Equipment satin-finish band for a mirror-polished look. The easy-to-install ribbed chrome band is a high-contrast addition to a painted battery cover or the perfect finishing touch to the Chrome Battery Cover P/N 66375-06.

66439-07 **\$33.95**
Fits '06-later Dyna models (except FLD, FXDL, '13-later FXDB and '14-later FXDF). Also fits models equipped with Battery and Electrical Panel Cover Kit P/N 61300186.

J. BATTERY COVER BAND – “HARLEY-DAVIDSON” SCRIPT

Replace the Original Equipment satin aluminum trim band with a splash of chrome. This easy-to-install custom contoured trim band features a black-filled embossed “Harley-Davidson” script design and offers a stunning contrast to the factory painted battery cover or a great finishing touch for the Chrome Battery Cover P/N 66375-06 or 61300186.

66443-06 **\$39.95**
Fits '06-later Dyna models (except FLD, FXDL, '13-later FXDB and '14-later FXDF). Also fits models equipped with Battery and Electrical Panel Cover Kit P/N 61300186.

K. BATTERY COVER BAND – SKULL

Add a sinister touch to your Dyna motorcycle. This easy-to-install chrome band features a 3-dimensional skull design set off with black accents. Designed to replace the Original Equipment satin aluminum band, this chrome skull trim offers a stunning contrast to the factory painted battery cover or a great finishing touch for the Chrome Battery Cover P/N 66375-06.

66442-06 **\$39.95**
Fits '06-later Dyna models (except FLD, FXDL, '13-later FXDB and '14-later FXDF). Also fits models equipped with Battery and Electrical Panel Cover Kit P/N 61300186.

L. BATTERY COVER

This one-piece, chrome-plated Battery Cover has the top and side cover all-in-one. Bottom of cover is accented with a gloss black decal with Bar & Shield logo.

66192-99 Fits '91-'05 Dyna models. **\$54.95**

M. BATTERY SIDE COVER – CHROME

This chrome-plated cover is designed for use with the new Harley-Davidson® AGM sealed maintenance-free batteries and can be used in combination with Battery Top Cover P/N 66367-97 or 66368-97.

66718-01 **\$49.95**
Fits '97-'03 XL models and '97-'05 Dyna models.

N. CHROME BATTERY COVERS*

Chrome-plated battery enclosures include slotted openings for convenient visual check of battery fluid levels. Easy installation.

1. 66375-97 Chrome. **\$59.95**
Fits '97-'05 FXD/X/XT models. Stock on FXDL, FXDWG and FXDS-CONV. models.

2. 66340-78 Chrome Vented. **\$49.95**
Fits '82-'03 XL models, electric start FX, FXWG models and '91-'96 Dyna models.

3. 66358-83 U.S.A. Eagle. **\$59.95**
Fits '82-'03 XL models, electric start FX, FXWG models and '91-'96 Dyna models.

*NOTE: Battery dimensions of Harley-Davidson AGM Batteries P/N 65989-97A, 65989-90B and 65991-82B may not allow use of accessory battery side covers on XL and Dyna models.

O. CHROME BATTERY TOP COVER

Turn black to chrome with this easy-to-install cover.

66368-97 Fits '97-'05 Dyna models. **\$54.95**

A STRONG FOUNDATION

Being sure-footed at a stop or when parking your bike enhances your feeling of control and confidence. Adjusting the ride height by lowering the suspension may be the first step in fitting the bike to your inseam length. Combining a low-profile suspension and a narrow seat is the easiest way for a shorter rider to fit comfortably on a larger bike.



SUSPENSION

While most current Dyna® models are already equipped with low-profile suspension, Harley offers model-specific suspension options to improve your ride comfort.

ESTABLISH YOUR POSITION



HANDLEBARS

Where the bar positions your hands, wrists and arms directly affects how you feel on the motorcycle. The shape of the bar determines your reach to the hand controls and, therefore, your overall comfort.



SEATS

The right seat is equal parts ergonomics and comfort. Its shape anchors your position and determines the reach to the ground and to the controls and the padding supports your tailbone and hips to relieve stress and pressure. Pick the right one for you – and your passenger.



FOOT CONTROLS

Where your feet contact the controls can often determine how many miles you can put on in a day. Mid-controls position your feet below the knee for a sporting riding posture, while forward controls stretch your legs for a relaxed, laid-back posture. For more details, visit h-d.com/fitshop.

THE FIT SHOP LIST	2015	SUSPENSION	SEATS	HANDLEBARS	FOOT SUPPORTS
 <p>Here are a few options to consider when outfitting your bike to fit you. Find your model and flip to the pages for more information. For more details, visit h-d.com/fitshop.</p>	FLD	Low Suspension is Stock	Reduced Reach® Seats Brawler®/Sidekick® Seats Road Zeppelin® Seat Tallboy® Seat	Extreme Reduced Reach Bar Fat 12" or 16" Ape Bar Beach Bar Narrow Beach Bar Street Slammer Bar	Adjustable Passenger Pegs
	FXDL	Low Suspension is Stock	Reduced Reach Seats Brawler /Sidekick Seats Road Zeppelin Seat Tallboy Seat	Extreme Reduced Reach Bar	Forward Control Kit Reduced Reach Forward Controls Adjustable Highway Pegs
	FXDB	Low Suspension is Stock	Reduced Reach Seats Brawler /Sidekick Seats Road Zeppelin Seat Tallboy Seat	Extreme Reduced Reach Bar Fat Drag Bar Beach Bar Hollywood Bar Chizeled Bar Fat 12" or 16" Ape Bar Street Slammer Bar	Forward Control Kit Reduced Reach Forward Controls Further Forward Mid-Controls Rider Footboards Adjustable Highway Pegs
	FXDF	Profile® Low Front Suspension	Reduced Reach Seats Brawler /Sidekick Seats Road Zeppelin Seat Tallboy Seat	Extreme Reduced Reach Bar Fat Drag Bar Beach Bar Fat 12" or 16" Ape Bar Street Slammer Bar	Reduced Reach Forward Controls Adjustable Passenger Pegs
	FXDWG	Low Suspension is Stock	Reduced Reach Seats Brawler /Sidekick Seats Road Zeppelin Seat Tallboy Seat	Extreme Reduced Reach Bar Drag Bar Beach Bar Hollywood Bar Fat 12" or 16" Ape Bar Street Slammer Bar	Reduced Reach Forward Controls Adjustable Passenger Pegs

DYNA® 175

Suspension



A. PROFILE® LOW FRONT SUSPENSION – FXDF*

Designed by Harley-Davidson to lower the front fork approximately 1.0" while preserving ride quality. Springs are wound to allow a compliant, yet controlled ride. A perfect addition during the installation of chrome or gloss black lower fork sliders, the kit includes two fork springs, two damper tubes and two spring collars.

54676-09 **\$104.95**
Fits '08-later FXDF models. Stock on FXDFSE/2 models.

B. PROFILE LOW FRONT SUSPENSION – FXDWG*

Designed by Harley-Davidson to lower the front fork approximately 1.0" while preserving ride quality. A perfect addition during the installation of chrome or gloss black lower fork sliders, the kit includes springs that are progressively wound for a compliant, yet controlled ride. Must only be installed on vehicles equipped with low-profile rear suspension.

54621-05 **\$104.95**
Fits '00-later FXST, FXSTB and FXSTC models equipped with Profile® Low Rear Suspension P/N 54648-00A, 54665-03, 54651-05A, 54652-05 or Rear Lowering Kit P/N 54001-04A. Also fits '00-'05 FXDWG models equipped with Low Rear Shock Kit P/N 54594-03 or Premium Billet Profile Low Rear Suspension P/N 54592-03.

C. PROFILE LOW REAR SHOCK KIT*

Plant your feet firmly on the ground. This reduced length version of the Original Equipment rear suspension lowers the seat height by approximately 1.0". Shocks feature chrome-plated springs and body caps and suspension preload is adjustable for rider and passenger load.

54625-06 **\$239.95**
Fits '06-'09 FXD, FXDC and FXDWG models. (Lowers '06-'09 FXDL, '08-'09 FXDF and FXDB models 1/4".) Does not lower '10-later Dyna® models.

54594-03 **\$239.95**
Fits '93-'05 FXD, FXDL, FXDC and FXDWG models. Does not lower '01-'05 FXDL models.

D. PREMIUM PROFILE LOW REAR SUSPENSION KIT*

Introduced on the '08 FXDF model, these custom rear shocks lower your bike while they raise the level of style. These low-profile shocks lower the seat height by approximately 1.0". The rear shock and spring is completely covered with mirror-polished and chrome-plated sleeves for a sleek, beefy look.

54619-08 **\$429.95**
Fits '07-later FXD, FXDC and FXDWG models. Stock on '08-later FXDF. Fits but does not lower '07-later FXDL, FXDB and '10-later FXD, FXDC and FXDWG models. '07 Dyna models require separate purchase of Chrome Belt Guard Kit P/N 60633-08. Does not fit with H-D® Detachables™ Saddlebags P/N 90181-08.



A. PROFILE LOW FRONT SUSPENSION – FXDF MODELS

B. PROFILE LOW FRONT SUSPENSION – FXDWG MODELS



C. PROFILE LOW REAR SHOCK KIT

D. PREMIUM PROFILE LOW REAR SUSPENSION KIT



***WARNING:** Installation of any accessory suspension components may affect cornering clearance and jiffy stand operation. This could distract the rider, causing loss of control and death or serious injury.



***WARNING:** The Profile Low Front Spring Kit cannot be used independently and must be used with the appropriate Profile Rear Shock Lowering Kit. Installation of any accessory suspension components may affect cornering clearance and jiffy stand operation. This could distract the rider, causing loss of control and death or serious injury.

Notice: The prices appearing in this catalog are the manufacturer's suggested retail prices. Actual retail prices may vary.

176 DYNA®

Foot Controls

A. STANDARD FORWARD CONTROLS*

Stretch out for maximum comfort and style. This complete kit includes all components necessary to convert a mid-control equipped Dyna® model to forward controls. Moves controls 11.0" forward from mid-control foot position. Kit is available in chrome or gloss black to match your customizing style.

Fits '06-later Dyna models with mid-controls. FLD models require separate purchase of footpegs.

49080-06A	Chrome.	\$369.95
49021-09	Gloss Black.	\$369.95

Fits '93-'05 Dyna models. Stock on '03-'05 FXDWG models. Not for use with Engine Guard on FXD and FXDL models.

49080-03A	Chrome.	\$369.95
------------------	---------	-----------------

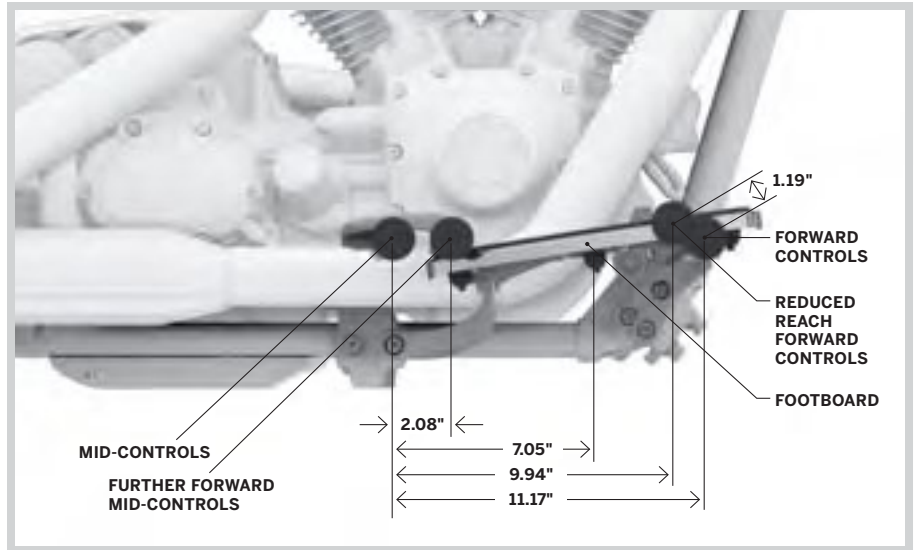

FOOT CONTROL POSITION COMPARISON



**A. STANDARD FORWARD CONTROLS
(SHOWN WITH OPTIONAL BILLET STYLE BRAKE LEVER)**



**A. STANDARD FORWARD CONTROLS –
CHROME**



**A. STANDARD FORWARD CONTROLS –
GLOSS BLACK**



***WARNING:** Installation of accessory Forward Control Kits may affect cornering clearance. This could distract the rider, causing loss of control, resulting in death or serious injury.

Notice: The prices appearing in this catalog are the manufacturer's suggested retail prices. Actual retail prices may vary.



B. REDUCED REACH FORWARD CONTROL CONVERSION KIT (SHOWN WITH OPTIONAL BILLET STYLE BRAKE LEVER)

B. REDUCED REACH FORWARD CONTROL CONVERSION KIT*

Love the look and riding position you get with forward controls but not comfortable with the long stretch forward? This Forward Control Conversion Kit repositions the Original Equipment footpegs and foot controls up and back by over 1.0", positioning the controls closer to the rider for added comfort and confidence. The reduced reach places the rider's boot at the proper pivot point for improved leverage, while maintaining the "foot-forward" riding profile. This easy-to-install Conversion Kit includes heavy-duty steel mounts and shortened brake rod and reuses Original Equipment control supports and brake and shift levers or can be personalized with your choice of custom lever styles.

50700005 **\$169.95**
Fits '06-later Dyna® models (except FLD) equipped with forward controls.



B. REDUCED REACH FORWARD CONTROL CONVERSION KIT

C. REDUCED REACH FORWARD CONTROL KIT*

Want to stretch the riding position of your mid-control equipped model, but not comfortable with the long reach to factory-position forward controls? This complete kit is the perfect alternative. It positions the feet up and forward 10.0" from the mid-control position, but 1.0" closer to the rider than the standard position factory forward controls, placing the rider's boot at a comfortable pivot point for improved support and leverage. Available in chrome or gloss black finish, the kit includes left and right footpeg supports, brake and shift lever assemblies, brake and shift linkages and all required hardware.

Fits '06-later Dyna models equipped with mid-controls. FLD models require separate purchase of footpegs.

50700007	Gloss Black.	\$399.95
50700008	Chrome.	\$399.95



C. REDUCED REACH FORWARD CONTROL KIT – CHROME



C. REDUCED REACH FORWARD CONTROL KIT – GLOSS BLACK



***WARNING:** Installation of accessory Forward Control Kits may affect cornering clearance. This could distract the rider, causing loss of control, resulting in death or serious injury.

Notice: The prices appearing in this catalog are the manufacturer's suggested retail prices. Actual retail prices may vary.

178 DYNA®

Foot Controls

A. FURTHER FORWARD MID-CONTROL KIT

Feel a little cramped when your feet are placed on the standard-location mid-controls? This kit repositions the controls 2.0" forward of the stock location, eliminating the "knees-high" riding attitude while maintaining a sporty upright riding posture. The forward location provides an open path for your feet to aid maneuvering the bike while parking and improves access to the jiffy stand for a shorter rider. Kit includes chrome left and right footrest brackets, highly polished brake lever and chrome shift lever. Use stock footpegs, brake and shift linkages or, choose from other Dyna® collection offerings to complete your look.

50500386 **\$319.95**
Fits '06-later Dyna models with mid-controls. Original Equipment on '14-later FXDL models.



A. FURTHER FORWARD MID-CONTROL KIT – RIGHT SIDE



A. FURTHER FORWARD MID-CONTROL KIT

B. RIDER FOOTBOARD KIT

Convert your Dyna model to touring-oriented footboard-based controls. Ideal for riders with an inseam too long for mid-controls or for riders who prefer the extra foot room on long rides, this complete kit moves the foot brake and shift lever forward from the standard position. The installation places the rider into a comfortable upright posture with a flat foot and bent knee profile. This position provides additional support by allowing the legs to take some of the rider's weight, while providing the freedom to reposition the feet during the ride. The kit includes left and right footboards with inserts, footboard supports, brake lever, brake and shift linkage, brake pedal pad and all required hardware. Installation reuses Original Equipment shift lever. Customize the look by adding your choice of accessory traditional D-shaped rider footboard inserts and large brake pedal pads.

50500247 **\$399.95**
Fits '06-later FXD, FXDB, FXDC and '06-'13 FXDL models. Also fits '06-'08 FXDWG models. Stock on '12-later FLD models. Not for use with frame-mounted highway pegs.



B. RIDER FOOTBOARD KIT – LEFT SIDE



B. RIDER FOOTBOARD KIT – RIGHT SIDE



B. RIDER FOOTBOARD KIT

Notice: The prices appearing in this catalog are the manufacturer's suggested retail prices. Actual retail prices may vary.



C. ADJUSTABLE HIGHWAY PEG MOUNTING KIT



C. ADJUSTABLE HIGHWAY PEG MOUNTING KIT*

Versatility with style and comfort. Choose from several H-D® custom footpegs to complete the cruiser look. Easy to install.

49002-98 **\$149.95**

Fits Dyna® models with Original Equipment mid-controls or Further Forward Mid-Control Kit P/N 50500386. Will not fit models equipped with engine guards.

D. HIGHWAY PEG MOUNTING KIT*

Kick back and cruise. Kit includes chrome mounting plates, chrome footpeg supports and all necessary mounting hardware. Uses H-D® male-mount footpegs.

49019-95 **\$149.95**

Fits Dyna models with Original Equipment mid-controls or Further Forward Mid-Control Kit P/N 50500386. Will not fit models equipped with engine guards.

E. RIDER FOOTPEG HEEL RESTS

Give your feet a rest while you're stretching out on your forward controls. These adjustable billet-style Rider Footpeg Heel Rests reduce fatigue and make you look as good as you feel. Just add a pair of matching shifter pegs to complete the custom look (sold separately).

50227-01 **\$124.95**

Fits '93-'02 FXDWG and '89-later FX Softail® models. Also fits Dyna models equipped with Forward Control Kit P/N 49080-06A, 49021-09 or 49080-93A.



D. HIGHWAY PEG MOUNTING KIT



E. RIDER FOOTPEG HEEL RESTS

F. JIFFY STAND EXTENSION KIT

Jiffy Stand Extension kits have been ergonomically designed to simplify the deployment and retraction of the jiffy stand. The extension is shaped to simplify locating the tab with your boot and aid in swinging the jiffy stand into position. The move feels natural and adds confidence when parking your motorcycle in a tight spot. Kit mounts to Original Equipment jiffy stand and includes all required mounting hardware.

5000032 **\$39.95**

Fits '93-later Dyna models (except FXDX/T, FXDS-CONV., '01-'04 FXDL, FXDWG2/3, FXR2/3/4, FXDSE/2 and FXDFSE/2).

G. RIDER FOOTBOARD HEEL GUARD

Avoid damaged boots and hours of cleaning melted rubber scuff marks from your exhaust shield. This Heel Guard mounts to the right-side rider footboard and protects your boot from contact with the hot exhaust shield. The subtle curved shape keeps the boot heel away without restricting fore-and-aft movement of the rider's foot. Kit includes chrome guard with cutaway Bar & Shield logo and all mounting hardware.

50500225 **\$64.95**

Fits '12-later FLD, '86-later FL Softail, '86-later Touring and '09-later Trike models equipped with Traditional and Swept Wing footboards. Does not fit models equipped with Half-Moon, Tapered or Burst footboards, Extended Reach Rider Footboards P/N 50409-04 or 54145-10, Rider Running Boards P/N 50500158 or Screamin' Eagle® Fat Exhaust Shield Kits.



F. JIFFY STAND EXTENSION KIT



G. RIDER FOOTBOARD HEEL GUARD



***WARNING:** Do not use highway pegs under normal stop and go operating conditions. Doing so could result in death or serious injury.

Notice: The prices appearing in this catalog are the manufacturer's suggested retail prices. Actual retail prices may vary.

180 DYNA®

Foot Controls

A. BILLET STYLE REAR BRAKE LEVER

Styled to complement our billet style mirror stems and hand and foot controls, these slotted Rear Brake Levers are forged from 2014-T6 aluminum, then machined and polished for a beautiful, custom look. Available in your choice of mirror chrome, satin black powder coat or edge cut black anodized and machined aluminum finishes. Brake Pedal Pads sold separately.

Fits '03-later Dyna® models equipped with forward controls.

42666-03	Chrome.	\$139.95
41600003	Edge Cut.	\$139.95
46873-09	Satin Black.	\$139.95

B. BILLET STYLE SHIFT LEVER

Styled to complement our billet style mirror stems, these Billet Style Shift Levers are forged from 6061-T6 aluminum, then machined and finished in chrome, satin black or edge cut styles for a beautiful, custom look. Includes chrome hardware.

Fits '91-later Dyna (except '14-later FXDL or models equipped with Further Forward Mid-Control Kit P/N 50500386) and '90-later FX Softail® models.

34539-00	Chrome.	\$89.95
34043-10	Edge Cut.	\$89.95
34016-08	Satin Black.	\$89.95



A. BILLET STYLE REAR BRAKE LEVER – CHROME



B. BILLET STYLE SHIFT LEVER – CHROME



A. BILLET STYLE REAR BRAKE LEVER – EDGE CUT



B. BILLET STYLE SHIFT LEVER – EDGE CUT



A. BILLET STYLE REAR BRAKE LEVER – SATIN BLACK



B. BILLET STYLE SHIFT LEVER – SATIN BLACK

Notice: The prices appearing in this catalog are the manufacturer's suggested retail prices. Actual retail prices may vary.



C. SHIFTER LINKAGE COVER – “HARLEY-DAVIDSON” SCRIPT

C. SHIFTER LINKAGE COVER – “HARLEY-DAVIDSON” SCRIPT

A simple and inexpensive way to detail your Dyna® model. This easy-to-install chrome-plated cover conceals the stock shifter linkage for a brilliant finish. Kit includes all necessary mounting hardware.

33878-04 **\$49.95**
 Fits '97-'05 FXDWG and '93-'05 Dyna models equipped with Forward Control Kit P/N 49080-03.

D. CUSTOM GEAR SHIFT LINKAGES

Kick your custom into gear with this collection of high-quality custom shift linkages. Available in a variety of designs to match your bike's style, these linkages feature aircraft-quality rod ends for easy adjustment and smooth operation. The easy-to-install linkage kit includes a transmission lever cover and decorative acorn nuts and bolts for a complete custom look.

Fits '06-later Dyna® models equipped with forward controls.

- | | | |
|--------------------|---------------------------------|-----------------|
| 1. 33900103 | Silencer Brushed Nickel. | \$129.95 |
| 2. 33917-09 | Diamond Black. | \$129.95 |
| 3. 33745-09 | Black Anodized Slotted. | \$129.95 |
| 4. 34848-09 | Skull. | \$129.95 |
| 5. 33838-09 | Flame. | \$149.95 |
| 6. 33761-09 | Slotted with Bar & Shield Logo. | \$129.95 |



D. CUSTOM GEAR SHIFT LINKAGES

E. POLISHED SHIFT LINKAGE

Replace your zinc-plated Original Equipment shift linkage with this polished stainless steel linkage.

33872-06 **\$84.95**
 Fits '06-later Dyna models equipped with mid-controls.

F. REAR MASTER CYLINDER COVER – CHROME

An easy way to add chrome to your bike with this chrome-plated version of the stock master cylinder cover.

46425-05A **\$39.95**
 Fits '06-later Dyna non-ABS models, Softail® and '05-'07 Touring Models.



E. POLISHED SHIFT LINKAGE



F. REAR MASTER CYLINDER COVER – CHROME

Notice: The prices appearing in this catalog are the manufacturer's suggested retail prices. Actual retail prices may vary.

182 DYNA®

Foot Controls

A. PASSENGER FOOTPEG SUPPORT KIT – WRINKLE BLACK

Add footpegs to your solo seat-equipped Dyna® motorcycle. Kit includes wrinkle black finished left and right footpeg supports and mounting hardware. Footpegs and footpeg hardware sold separately.

50210-06 Fits '06-later Dyna models. **\$74.95**

B. PASSENGER FOOTPEG SUPPORT KIT – CHROME

These chrome-plated supports add a touch of style to your Dyna motorcycle. Kit includes left and right supports. Footpegs and footpeg hardware sold separately.

49249-06 Fits '06-later Dyna models. **\$129.95**

C. PASSENGER FOOTBOARD SUPPORT KIT

Add the comfort and convenience of passenger footboards to your Dyna motorcycle. This Support Kit is designed to allow installation of Traditional D-Shaped, Swept Wing, Tapered or Old-Style Passenger Footboards (sold separately) on Dyna models. Kit includes left and right supports, footboard mount hinge pins and installation hardware.

Fits '06-later Dyna models.

49279-06 Chrome. **\$239.95**

49349-07 Black. **\$199.95**

D. ADJUSTABLE PASSENGER FOOTPEG MOUNT KIT

Maximize your passenger's riding comfort. Proper foot position reduces the cramped or stretched-out feeling and relieves pressure on the knees and the tail bone. These Adjustable Mounts raise and lower the passenger footpeg to accommodate taller and shorter passengers. Easy to adjust with common tools, the mount adjusts through a 360° range (depending on model), allowing both fore and aft and up and down height adjustment. Kit includes left and right adjustable support assembly and all required mounting hardware. Footpegs sold separately.

50763-09 **\$149.95**

Fits models with H-D male-mount style passenger footpeg supports (except Softail® models). Does not fit with Heel Raiser Footpeg Kit P/N 50178-09. Does not fit the rider position.



A. PASSENGER FOOTPEG SUPPORT KIT – WRINKLE BLACK



B. PASSENGER FOOTPEG SUPPORT KIT – CHROME



C. PASSENGER FOOTBOARD SUPPORT KIT – BLACK



C. PASSENGER FOOTBOARD SUPPORT KIT – CHROME



D. ADJUSTABLE PASSENGER FOOTPEG MOUNT KIT



***WARNING:** Do not use highway pegs under normal stop and go operating conditions. Doing so could result in death or serious injury.

Notice: The prices appearing in this catalog are the manufacturer's suggested retail prices. Actual retail prices may vary.



E. MINI FOOTBOARD KIT – (LARGE CHROME SHOWN)

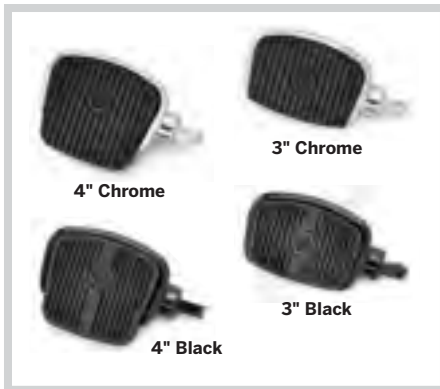

E. MINI FOOTBOARD KIT

E. MINI FOOTBOARD KIT

This Footboard Kit can be installed in place of traditional footpegs and provides a little additional leg support and more options to move your legs around on a long ride. Mini Footboards mount to the standard H-D® style footpeg supports and can be used in many rider, passenger and highway peg applications. Sole-gripping rubber complements Original Equipment or accessory footboards and footpegs and adds vibration isolation and a rich appearance.

Fits rider position:

VRSC™ models with forward controls (except VRSCDX and VRSCF), '06-earlier XL, '07-'10 XL883, XL883R, XL883C, XL1200C, XL1200R and '07-'11 XL1200L, Dyna® models (except FLD) and Softail® models with forward controls (except FXCW, FXCWC, FXS, FXSB or FXSBSE).

Fits passenger position:

All models with H-D male-mount passenger peg mounts (except '06-earlier VRSC, '03-earlier XL, '05-earlier Dyna and Softail models equipped with Shotgun exhaust). Softail models require separate purchase of Support Kit P/N 50454-09.

Fits highway peg position:

All models with frame-mount or engine guard-mount highway pegs (except Whiskers Adjustable Highway Bar P/N 50855-09 and 50865-09).

50500139	Small 3.0" – Chrome.	\$129.95
50500144	Small 3.0" – Gloss Black.	\$129.95
50500109	Large 4.0" – Chrome.	\$129.95
50500124	Large 4.0" – Gloss Black.	\$129.95

F. PASSENGER FOOTBOARD PANS – CHROME

Replace the factory black painted passenger footboard with the custom look of smooth chrome. The kit includes left- and right-hand traditional D-shaped footboard pans, chrome-plated and ready to install with your Original Equipment hardware. Footboard inserts and footboard supports sold separately.

50752-04 \$169.95
Fits '86-later Touring and Trike, '00-later Softail and '06-later Dyna models equipped with passenger footboard supports.

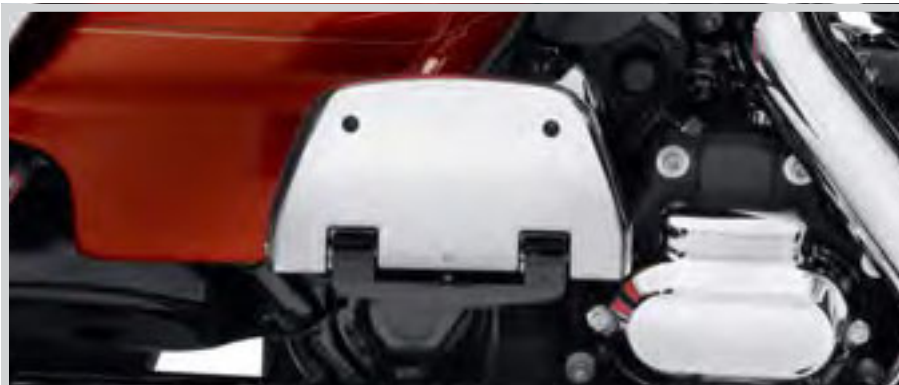

F. PASSENGER FOOTBOARD PANS – CHROME

G. SWEEP WING PASSENGER FOOTBOARD PANS

These unique Sweep Wing Passenger Footboard pans complement the Sweep Wing Rider Footboard shape and allow you to replace the Original Equipment passenger footpegs on certain models with footboards. When folded, the footboard displays a mirror-chrome surface in your choice of smooth or "ball-milled" grooved design. Footboard inserts and footboard supports sold separately.

Fits '86-later Touring, '00-later Softail and '06-later Dyna models equipped with passenger footboard supports. Does not fit Trike models.

50357-04	Chrome – Grooved.	\$169.95
50716-04	Chrome – Smooth.	\$159.95



G. SWEEP WING PASSENGER FOOTBOARD PANS – CHROME GROOVED



G. SWEEP WING PASSENGER FOOTBOARD PANS – CHROME SMOOTH

H. HALF-MOON PASSENGER FOOTBOARD PANS AND INSERTS

Styled to match the Half-Moon Rider Footboards, these classic passenger footboards add both style and comfort to your nostalgic ride. Available in mirror-finish chrome or gloss black finish, the kit includes left and right footboard pan and vibration-isolation footboard inserts. Model-specific footboard mounts are sold separately.

Fits '86-later Touring, '00-later Softail and '06-later Dyna models equipped with passenger footboard supports. Does not fit Trike models.

50807-08	Chrome.	\$189.95
50810-08	Gloss Black.	\$179.95



H. HALF-MOON PASSENGER FOOTBOARD PANS – CHROME



H. HALF-MOON PASSENGER FOOTBOARD PANS – GLOSS BLACK

Notice: The prices appearing in this catalog are the manufacturer's suggested retail prices. Actual retail prices may vary.

184 DYNA®

Engine Guards

A. ENGINE GUARD KIT*

Protect your bike without sacrificing ground clearance or style. The one-piece Engine Guard is designed to complement the lines of the motorcycle and the available chrome or gloss black finish adds the perfect finishing touch.

For use with the mid or forward controls. Fits '06-later Dyna® models, '14-later FXDL and all '15-later Dyna models in India require separate purchase of Horn Relocation Bracket P/N 69000058. Fits with Oil Cooler Kit P/N 26151-07. FXDSE/2 and FXDFSE/2 requires removal of front chin spoiler and separate purchase of Regulator Caddy P/N 70464-08A. '06-'11 models equipped with evap canister also require separate purchase of Canister Bracket P/N 47207-06. '12-later models equipped with evap canister require separate purchase of Canister Relocation Kit P/N 60800005.

49010-06 Chrome. **\$214.95**

49320-09 Gloss Black. **\$214.95**

For use with mid-controls. Fits '91-'05 Dyna models (except '93-'05 FXDWG and '94-'05 FXDS-CONV. models). Not for use with Dyna Forward Control Kit P/N 49080-93 or Footboard Kit P/N 50580-01 and 50601-01. Will fit with Leather Tool Roll Kit P/N 91714-97A.

49007-90A Chrome. **\$214.95**

For use with forward controls. Fits '93-'05 FXDWG and FXDS-CONV. models. Also fits FXDX models. (Compatible with Forward Control Kit P/N 49080-93 only on FXDWG models.) Will not fit with Oil Cooler P/N 62871-00A, 26081-05 Dyna Fan Kit P/N 91551-00A or 91552-00A, Dyna Motor Mount Cover P/N 48426-98, Chrome Front Spoiler P/N 57081-01 or with Color-Matched Front Spoilers.

49010-93 Chrome. **\$214.95**

Also available:

EVAPORATIVE CANISTER RELOCATION KIT

60800005 **\$29.95**

Required when mounting Engine Guard P/N 49320-09 or 49010-06 on '12-later Dyna models designated for California and Asia-Pacific markets.

B. SOFT LOWERS

Extend your riding season. Full coverage Soft Lowers provide wind and mud protection for the rider's legs and boots and minimize cold updrafts as the weather changes. Covers are custom shaped to hug the engine guard to minimize flapping and they simply clip in place for speedy installation as the weather changes. Two-way zippered outer edge accommodates guard-mounted highway pegs in almost any position. Reflective piping provides added visibility and convenient zippered pockets provide additional storage for maps or other small items.

57100212 **\$89.95**

Fits '06-later FXD, FXDB, FXDC and FXDL models equipped with Engine Guard P/N 49010-06 or 49320-09. Does not fit models with forward controls or footboards.



A. ENGINE GUARD KIT – CHROME (49010-06 SHOWN)



A. ENGINE GUARD KIT – GLOSS BLACK



B. SOFT LOWERS



B. SOFT LOWERS



***WARNING:** These guards may provide limited leg and cosmetic vehicle protection under unique circumstances (fall over while stopped, very low speed slide). They are not made nor intended to provide protection from bodily injury in a collision with another vehicle or any other object.

Notice: The prices appearing in this catalog are the manufacturer's suggested retail prices. Actual retail prices may vary.

DYNA® 185

Engine Guards

NEW



C. MUSTACHE ENGINE GUARD – CHROME

C. MUSTACHE ENGINE GUARD*

Combine classic shape and modern function for a unique twist on engine protection. The flow of this engine guard complements the bike's traditional style while the gracefully curved upper section incorporates highway pegs into the shape. The integrated rubber pads offer a comfortable and slip-resistant cushion for your feet while traveling the open road. One-piece engine guard kit includes all required mounting hardware.

Fits '06-later Dyna® models. '14-later FXDL and all '15-later Dyna models in India require separate purchase of Horn Relocation Bracket P/N 69000058. Fits with Oil Cooler Kit P/N 26151-07. FXDSE/2 and FXDFSE/2 requires removal of front chin spoiler and separate purchase of Regulator Caddy P/N 70464-08A. '06-'11 models equipped with evap canister also require separate purchase of Canister Bracket P/N 47207-06. '12-later models equipped with evap canister require separate purchase of Canister Relocation Kit P/N 60800005.

49000077	Chrome.	\$269.95
49000078	Gloss Black.	\$269.95

Also available: (not shown)

HORN BRACKET ADAPTER

Required when mounting Engine Guard P/N 49010-06, 49320-09, 49000077 or 49000078 on '14-later FXDL models and all '15-later Dyna models for India.

69000058		\$9.95
-----------------	--	---------------

Fits '14-later FXDL models and all '15-later Dyna models for India equipped with Engine Guard P/N 49010-06, 49320-09, 49000077 or 49000078.

NEW



C. MUSTACHE ENGINE GUARD – GLOSS BLACK

D. SWITCHBACK™ REAR SADDLEBAG GUARDS – CHROME*

Add protection and style to your ride. These chrome guards add a traditional Bagger look to the Dyna® Switchback™ model and protect the leading edge of the saddlebags. The innovative design allows the guards to be removed with the detachable saddlebags for a stripped-down look and the integrated stand keeps the bags upright and off the ground when off the bike. Kit includes left and right guards and all necessary mounting hardware.

90201044		\$299.95
-----------------	--	-----------------

Fits '12-later FLD models.

NEW



D. SWITCHBACK SADDLEBAG GUARDS – CHROME



***WARNING:** These guards may provide limited leg and cosmetic vehicle protection under unique circumstances (fall over while stopped, very low speed slide). They are not made nor intended to provide protection from bodily injury in a collision with another vehicle or any other object.

Notice: The prices appearing in this catalog are the manufacturer's suggested retail prices. Actual retail prices may vary.

DYNA

186 DYNA®

Chassis Trim – Front End

A. LOWER FORK SLIDERS – CHROME

Competitively priced, these chrome-plated Lower Fork Sliders give your bike up-front style. A perfect addition during the installation of Profile® Low Front suspension components. To ensure proper fitment and function, these sliders are manufactured from Original Equipment components. Form follows function, with polished, triple chrome-plating and a stamped "Harley-Davidson" logo for product identification. Kit includes right and left side sliders.

45500267 **\$449.95**
Fits '14-later FXDL models with dual disc brakes.

45500064 **\$449.95**
Fits '06-later Dyna® models (except FLD, FXDF, FXDWG, FXDFSE/2, FXDSE/2 and '14-later FXDL).

45500065 **\$469.95**
Fits '08-later FXDF models.

45500066 **\$449.95**
Fits '06-later FXDWG models.

45500067 **\$449.95**
Fits '12-later FLD models.

46492-00 **\$429.95**
Fits '00-'07 XL models (except XL883R, XL1200S and XL1200R) and '00-'03 FXD and '01-'03 FXDL models.

45275-98 **\$429.95**
Fits '88-'99 Sportster® models and FXD Super Glide®, '87-later FXLR and '88-'99 FXR and FXRS. (Does not fit Sportster Sport models.)

46477-00 **\$449.95**
Fits '00-'05 FXDWG, '00-'06 FXST and FXSTB models.

45305-98 **\$449.95**
Fits '91-'99 FXDWG, FXST, FXSTB and FXSTC models.

B. LOWER FORK SLIDERS – GLOSS BLACK

These gloss black coated sliders are the ultimate extension of your bike's "dark side" and make a perfect custom addition to your blacked-out ride. Manufactured to Original Equipment specifications, the durable black coating is a great match to other H-D® black components. Add matching gloss black Billet Fork Slider Dust Covers P/N 45800014 for a complete look. Kit includes right and left sliders.

45500273 **\$449.95**
Fits '14-later FXDL models with dual disc brakes.

45500073 **\$449.95**
Fits '06-later FXDWG models.

45500074 **\$449.95**
Fits '06-later Dyna models (except FLD, FXDF, FXDWG, FXDFSE/2, FXDSE/2 and '14-later FXDL).

C. FRONT END KIT – CHROME

The front forks on a Harley-Davidson® motorcycle set the tone for the bike and can lead the way to a full-bore custom statement. So start customizing by adding chrome where it counts. A perfect addition during the installation of Profile Low Front suspension components, the kit includes fork sliders, chrome dust caps, axle nut covers and upper fork nut covers. Chrome Front End Package price does not include labor or supplies.

45800076 **\$549.95**
Fits '14-later FXDL models with dual disc brakes.

D. FRONT END KIT – GLOSS BLACK

Lead the way to the dark side. This complete blacked-out Front End Kit includes all the major components required to convert the Original Equipment satin-finished front end to a dark custom style. A perfect addition during the installation of Profile Low Front suspension components, the kit includes gloss black fork sliders, gloss black fork dust covers and gloss black front axle nut cover kit.

45800075 **\$549.95**
Fits '14-later FXDL models with dual disc brakes.

45800010 **\$549.95**
Fits '08-later FXDWG models. Includes gloss black upper fork nut covers.

45800011 **\$549.95**
Fits '08-later Dyna models (except FLD, FXDF, FXDFSE/2, FXDSE/2, FXDWG and '14-later FXDL).



A. LOWER FORK SLIDERS – CHROME ('06 DYNA SHOWN)



A. LOWER FORK SLIDERS – CHROME



B. LOWER FORK SLIDERS – GLOSS BLACK (SHOWN WITH BILLET FORK SLIDER DUST COVERS)



B. LOWER FORK SLIDERS – GLOSS BLACK



C. FRONT END KIT – CHROME (45800076 SHOWN)

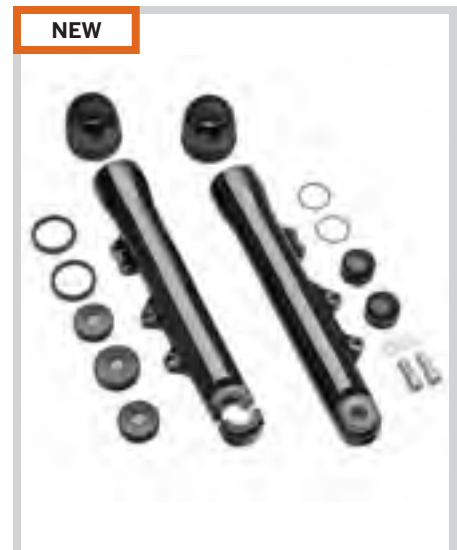

D. FRONT END KIT – GLOSS BLACK (45800075 SHOWN)

Notice: The prices appearing in this catalog are the manufacturer's suggested retail prices. Actual retail prices may vary.



E. BILLET FORK SLIDER DUST COVERS – CHROME



E. BILLET FORK SLIDER DUST COVERS – GLOSS BLACK



F. DECORATIVE FORK JOINT COVERS – CHROME



G. LOWER FRONT FORK DUST COVERS – CHROME



H. FRONT AXLE NUT COVERS – CHROME



H. FRONT AXLE NUT COVERS – GLOSS BLACK

E. BILLET FORK SLIDER DUST COVERS

Oversized billet covers are designed to replace the Original Equipment dust caps, creating a big, beefy look to the front forks. Available in your choice of mirror chrome or gloss black finish, these covers are the perfect addition to matching accessory fork sliders and upper fork nut covers.

Fits '06-later Dyna® models (except FLD and FXDSE/2). Does not fit with Screamin' Eagle® Chrome Fork Brace P/N 46634-06 or 46595-06A and Turn Signal Relocation Kit P/N 69433-08A.

46889-06	Chrome.	\$69.95
45800014	Gloss Black.	\$69.95

F. DECORATIVE FORK JOINT COVERS – CHROME

Add a bigger, beefy look to the fork slider dust covers without disassembling the front fork. This polished and chrome-plated kit is easy to install without tools.

45415-82
Fits '84-'99 FXSTC, '84-later FXST, FXSTB, '93-'05 FXDWG and '80-'86 FXWG models.

\$64.95

G. LOWER FRONT FORK DUST COVERS – CHROME

Replace your stock black rubber fork slider seal with this beautiful, chrome billet 6061-T6 aluminum dust cover.

45243-00
Fits '84-'99 FXSTC, '84-later FXST, FXSTB and '91-'05 FXDWG and '80-'86 FXWG models.

\$64.95

H. FRONT AXLE NUT COVERS

Cover the front axle in style. Available in chrome or gloss black finish, custom Axle Nut Covers look great with Original Equipment satin-finish fork sliders or add the finishing touch to a complete chrome or blacked-out front end. These Axle Cover Kits are easy to install and include all necessary mounting hardware. Sold in pairs.

Fits '02-'11 VRSC™ (except VRSCF, VRSCR and '12-later VRSCDX), '15-later XG, '08-later XL, '08-later Dyna®, '07-later Softail® (except Springer™, FXCW, FXCWC, FLSTNSE, FXSBSE, FXST-Aus and FXSTD) and '08-later Touring and Trike models.

44117-07A	Chrome – Die-cast.	\$27.95
43000026	Gloss Black – Die-cast.	\$27.95
44116-07A	Chrome – Billet.	\$42.95
43428-09	Gloss Black – Billet.	\$42.95

Fits '00-'07 Touring models and '04-'07 Dyna models (except '04-'05 FXDWG and '07 FXDSE).

43061-04	Chrome – Billet.	\$42.95
43062-04	Chrome – Die-cast.	\$27.95

Fits '88-'07 XL, '91-'03 Dyna FXD, FXDX, FXDXT, FXDL, FXDS-CONV.; '93-'05 FXDWG, '84-'06 Softail (except Springer and FXSTD), '80-'99 Touring models. Also fits '88-'07 FXR and '87-later FLXR/FXRS-SP, FXWG models.

43899-86A	Chrome – Die-cast.	\$27.95
------------------	--------------------	----------------

188 DYNA®

Chassis Trim – Front End

A. BURST FRONT AXLE NUT COVERS

Finish your blacked-out forks in style. Rich black and prismatic machined surfaces provide the contrast and the race-track ridges and the inner spider design make a powerful visual statement. Easy to install kit includes mounting hardware.

43000031 \$69.95

Fits '02-'11 VRSC™ (except VRSCF, VRSCR and '12-later VRSCDX), '15-later XG, '08-later XL, '08-later Dyna®, '07-later Softail® (except Springer™, FXCW, FXCWC, FXSB, FXSBSE, FXSTD and FLSTNSE) and '08-later Touring and Trike models.

B. LOW-PROFILE FRONT AXLE NUT COVERS

Thanks to the tapered design, these die-cast Low-Profile Axle Covers appear smaller than a traditional axle cover. The brilliant chrome finish looks great with Original Equipment polished or accessory chrome fork sliders and the hidden fasteners keep the look clean.

47646-09 \$46.95

Fits '06-'11 VRSC (except VRSCF, VRSCR and '12-later VRSCDX) and '08-later Dyna models (except FXDSE).

C. "H-D MOTOR CO." LOGO FRONT AXLE NUT COVERS

Die-cast, chrome-plated covers feature the "Harley-Davidson Motor Co." logo in black. Includes Allen®-head set screws and wrench for easy installation.

44148-07A \$29.95

Fits '02-'11 VRSC (except VRSCF, VRSCR and '12-later VRSCDX), '15-later XG, '08-later XL, '08-later Dyna, '84-later Softail (except Springer, FXCW, FXCWC, FXSB, FXSBSE, FXST-Aus FXSTD and FLSTNSE) and '08-later Touring and Trike models.

43063-04 \$27.95

Fits '00-'07 Touring models and '04-'07 Dyna models (except '04-'05 FXDWG and '07 FXDSE).

D. WILLIE G SKULL FRONT AXLE NUT COVERS

Add a little attitude to your ride. The Axle Nut Covers are easy to install and include all necessary mounting hardware. Sold in pairs.

43163-08A \$34.95

Fits '02-'11 VRSC (except VRSCF, VRSCR and '12-later VRSCDX), '15-later XG, '88-later XL, '91-later Dyna, '84-later Softail (except Springer, FXCW, FXCWC, FXSB, FXSBSE, FXSTD and FLSTNSE) and '99-later Touring and Trike models.

E. TAPERED FRONT AXLE NUT COVERS

Thanks to an exclusive contoured profile, these unique chrome die-cast Front Axle Nut Covers appear smaller than others when installed. Sold in pairs.

44109-07 \$27.95

Fits '02-'11 VRSC (except VRSCF, VRSCR and '12-later VRSCDX), '08-later Dyna, '07-later Softail (except Springer, FXCW, FXCWC, FXSB, FXSBSE, FXSTD and FLSTNSE) and '08-later Touring models.

43051-01 \$27.95

Fits '00-'07 Touring models and '04-'07 Dyna models (except '04-'05 FXDWG and '07 FXDSE).

F. ALUMINATOR® FRONT AXLE NUT COVERS

Chrome-plated billet aluminum axle covers feature a classic Bar & Shield logo insert. Includes all necessary mounting hardware for easy installation.

44114-07 \$42.95

Fits '02-'11 VRSC models (except VRSCF, VRSCR and '12-later VRSCDX), '08-later Dyna, '07-later Softail models (except Springer, FXCW, FXCWC, FXSB, FXSBSE, FXSTD and FLSTNSE) and '08-later Touring models.

43059-04 \$42.95

Fits '00-'07 Touring models and '04-'07 Dyna models (except '04-'05 FXDWG and '07 FXDSE).

43907-94 \$42.95

Fits '88-'07 XL, '91-'03 Dyna FXD, FXDX, FXDXT, FXDL, FXDS-CONV.; '93-'05 FXDWG, '84-'06 Softail (except Springer and FXSTD), '80-'99 Touring models. Also fits '88-'07 FXR and '87-later FLXR/FXRS-SP, FXWG models.



A. BURST FRONT AXLE NUT COVERS



B. LOW-PROFILE FRONT AXLE NUT COVERS



C. "H-D MOTOR CO." LOGO FRONT AXLE NUT COVERS



D. WILLIE G SKULL FRONT AXLE NUT COVERS



E. TAPERED FRONT AXLE NUT COVERS



F. ALUMINATOR FRONT AXLE NUT COVERS

Notice: The prices appearing in this catalog are the manufacturer's suggested retail prices. Actual retail prices may vary.



G. FORK AXLE RETAINER NUT KIT – CHROME
(DYNA/XL SHOWN)



G. FORK AXLE RETAINER NUT KIT – CHROME
(FXDWG SHOWN)



H. FRONT WHEEL SPACERS – CHROME, STRAIGHT



H. FRONT WHEEL SPACERS – CHROME, TAPERED



I. SCREAMIN' EAGLE FORK BRACE – CHROME



J. CUSTOM FORK BRACE

G. FORK AXLE RETAINER NUT KIT – CHROME

It's the details that count. Complete the chrome transformation by adding this finishing touch to your chrome fork sliders. This Fork Axle Retainer Nut Kit includes the stylish chrome-plated nuts and chrome lockwashers necessary to replace the stock hardware.

45802-03 \$8.95

Fits '88-later XL models, '93-'05 Dyna® FXD, FXDL, FXDS-CONV., FXDX, FXDX-T models and '88-'94 FXR, FXRS, FXRS-SP, FXRS-CONV., FXLR and FXRT models.

45813-03 \$8.95

Fits '84-later Touring and Trike models, '86-'07 FLST, FLSTC, FLSTF, FLSTN, '91-'07 FXST and FXSTB, '07 FXSTC and '91-'05 FXDWG models.

Also available:

FORK SLIDER DRAIN SCREW KIT – CHROME

This Fork Slider Drain Screw Kit includes two chrome-plated drain screws and the seals required to replace the stock hardware.

45848-03 \$3.95

Fits '87-later Softail® (except Springer™, FXCW, FXCWC, FXSB, FXSBSE and FXSTD), '87-'13 Touring models and '93-'05 FXDWG models.

45815-03 \$3.95

Fits '73-'13 XL models (except XL Sport, XL883L, XL1200X and '11-later XL1200C), '78-'86 FX models, '94-'05 Dyna FXD/DL/DS-CONV., '99-'00 FXR2/3/4 models and '00-'07 FXSTD models.

H. FRONT WHEEL SPACERS – CHROME

Complete your total front end with these highly polished chrome-plated wheel spacers. Manufactured to the Original Equipment tolerances, they deliver exact fitment and custom shine.

41597-00 Straight. \$29.95

Fits '00-'06 FXST, FXSTB, FXSTD and '00-'05 FXDWG models. Also fits models equipped with Inverted Front Fork Kit and .75" Axle Kit P/N 42134-06 or Billet Fork Sliders P/N 46280-03. Does not fit '03-'04 FXSTDSE.

41616-02 Straight. \$29.95

Fits '00-'07 XL models and '00-'03 FXD, FXDL, FXDX, FXDXT and FXDS-CONV. models.

41420-08 Tapered. \$34.95

Fits '08-later Dyna models without ABS (except FLD, FXDWG, FXDF and FXDFSE/2). Does not fit with Typhoon Custom Wheel P/N 44615-08, 44657-08, 40774-10 or 43300053, Magnum 5 Custom Wheel P/N 43621-09, 40516-10 or 43300049 or Road Winder™ Custom Wheel P/N 44689-08.

41361-08 Tapered. \$34.95

Fits '08-later FLD, FXDF and FXDWG models without ABS.

I. SCREAMIN' EAGLE® FORK BRACE – CHROME

These chrome Fork Braces are machined from billet aluminum, then polished and chrome-plated to complement the curve of the front fender. The machined Screamin' Eagle® logo finishes the look with crisp detail. Easy to install, these braces offer increased torsional rigidity.

46595-06A \$219.95

Fits '06-later FXD, FXDB, FXDC, FXDL and '02-'08 VRSCA, VRSCB, VRSCD and VRSCX models.

46192-99A \$219.95

Fits '87-later XL (except XL883N, XL883L, XL1200N, XL1200T, XL1200X, '11-later XL1200C), '91-'05 Dyna (except FXDWG) and FXR models (except FXRT) with 39mm front forks. (Will not fit with Chrome Fork Sliders.)

J. CUSTOM FORK BRACE

This chrome-plated Fork Brace adds style to the front end. The cross-brace open web style reflects a performance heritage and the multi-piece design allows easy installation.

46097-98 41mm. \$159.95

Fits '93-'05 FXDWG and '84-later FX Softail models (except Springer, FXCW, FXCWC, FXS, FXSB, FXSBSE and FXSTD). (Will not fit with Chrome Lower Fork Sliders.)

190 DYNA®

Chassis Trim – Brakes

A. BRAKE CALIPER KIT – RED

Dress your bike in the latest high-performance look. Brilliant red calipers make a powerful visual statement and set your bike apart from the ordinary. Manufactured from Original Equipment components for proven performance, these calipers will add a stylish touch to the stock bike or add the perfect finish to a complete custom equipped with chrome or blacked-out wheels, rotors and fork sliders.

41300127 Front & Rear Kit. **\$399.95**
Fits '08-later Dyna® and '08-'14 Softail® models (except Springer™) equipped with single disc front brakes. Kit includes one front and one rear caliper. Brake pads sold separately.

41300126 Front – Single Disc. **\$249.95**
Fits '00-'03 XL, '00-'07 Dyna and '00-'07 Softail models with single disc front brakes. Brake pads sold separately.

41300120 Front – Dual Disc. **\$399.95**
Fits '02-'05 VRSC™, '00-'03 XL, '00-'07 Dyna and '00-'07 Touring models with dual disc front brakes. Brake pads sold separately.

B. BRAKE CALIPER KIT – CHROME

Add the shine of chrome to your bike with this highly polished Chrome Brake Caliper Kit. Manufactured from Original Equipment components for proven performance, these calipers add the finishing touch to a complete custom with chrome wheels, rotors and chrome fork sliders. (Brake pads and pad pins not included.)

44395-08 Front – Single Disc. **\$389.95**
Fits '08-later Dyna (except '14-later FXDL) and '08-'14 Softail models (except Springer) equipped with single disc front brakes.

44395-00A Front – Single Disc. **\$389.95**
Fits '00-'03 XL and '00-'07 Dyna and Softail (except Springer) models equipped with single disc front brakes.

44392-00A Front – Dual Disc. **\$799.95**
Fits '00-'03 XL, '02-'05 VRSC and '00-'07 Dyna, Softail and Touring models equipped with dual disc front brakes.

42047-08 Rear. **\$349.95**
Fits '08-later Dyna and Softail models.

42035-06 Rear. **\$449.95**
Fits '06-'07 Dyna models.

C. REAR BRAKE CALIPER BRACKET – CHROME

Manufactured from the Original Equipment components for exact fit, this mount will bolt to the existing mounting location.

42002-08 Fits '08-later Dyna models. **\$119.95**



A. BRAKE CALIPER KIT – RED
(41300127 SHOWN)



A. BRAKE CALIPER KIT – RED
(41300126 SHOWN)



A. BRAKE CALIPER KIT – RED
(41300120 SHOWN)



B. FRONT BRAKE CALIPER KIT – CHROME
(SHOWN WITH CHROME CALIPER BOLT COVER
KIT AND CALIPER INSERT)



B. FRONT BRAKE CALIPER KIT – CHROME



B. REAR BRAKE CALIPER KIT – CHROME
(SHOWN WITH CHROME BRACKET)



C. REAR CALIPER BRACKET – CHROME

Notice: The prices appearing in this catalog are the manufacturer's suggested retail prices. Actual retail prices may vary.



D. FRONT CALIPER COVER – CHROME (SHOWN WITH CHROME CALIPER BOLT COVER KIT)



D. REAR CALIPER COVER – CHROME

D. CALIPER COVER – CHROME

Chrome-plated caliper cover styled with stepped contours and textured recess for a distinctive look. Does not require brake line removal.

43759-00 Front. **\$42.95**
Fits left-hand calipers on '00-'07 FXDWG and '00-'07 Softail® models (except Springer™ and FXSTD models). Will not fit with braided brake lines.

43553-00 Rear. **\$38.95**
Fits '00-'05 Dyna® and '00-'07 Softail models (except '06-'07 FXST, FXSTB, FXSTS and FLSTFSE2). Will not fit with braided brake lines.

E. CUSTOM CALIPER BOLT COVER KIT

Cover your 12-point caliper bolts in chrome. These easy-to-install chrome covers are held firmly in place with a steel spring clip and are styled to match the Chrome Rocker Box Bolt and Headbolt Covers.

43824-03 Four Large Covers. **\$23.95**
Fits '00-later front and rear 12-point caliper mounting bolts (except Springer front calipers, '15-later XG, '08-later Touring, '08-later Trike and '06 VRSCR models).

40955-05 Four Large and Two Small Covers. **\$28.95**
Fits '00-later front brake calipers (except Springer models, '15-later XG, '04-later XL, '08-later Touring, '06-later VRSC models and models equipped with caliper covers). Also fits rear calipers on '06-later Softail models (except FXCW).

40959-05 Three Large and Two Small Covers. **\$23.95**
Fits '00-later rear brake calipers (except '15-later XG, '04-later XL, '08-later Touring, '06-later FXST, FXSTB, FXSTS, FLSTSB, '06-later VRSC models and models equipped with caliper covers).

F. BRAKE CALIPER INSERTS

Easy-to-install inserts add a finishing touch to the front and rear brake calipers. Select a style that follows your custom direction. Self-adhesive backing.

Fits '00-later front and rear brake calipers on all models (except Springer front, '08-later Touring, '08-later Trike, '04-later XL, '15-later XG and '06-later VRSC models).

1. 44542-03 Deep Dish. **\$16.95**

2. 44477-99 Classic Chrome. **\$16.95**

3. 44476-99 "Harley-Davidson" Script. **\$16.95**

4. 44474-99 Flames. **\$16.95**

G. BRAKE CALIPER TRIM DISCS

Available in 1.375" and 1.75" diameters to accommodate front and rear calipers on most '99-earlier models and front calipers on '00-later Springer models. Easy to install.

1. 44095-96 "H-D Motor Co." – 1.375" Diameter. **\$16.95**

44093-96 "H-D Motor Co." – 1.75" Diameter. **\$16.95**

2. 99661-92T Gold Live to Ride – 1.375" Diameter. **\$16.95**

99663-92T Gold Live to Ride – 1.75" Diameter. **\$16.95**

3. 99679-98 Flames – 1.375" Diameter. **\$11.95**



E. CUSTOM CALIPER BOLT COVER KIT



F. BRAKE CALIPER INSERT – DEEP DISH



F. BRAKE CALIPER INSERT – CLASSIC CHROME



F. BRAKE CALIPER INSERTS



G. BRAKE CALIPER TRIM DISCS

192 DYNA®

Chassis Trim – Front End

A. UPPER FORK NUT COVERS

Highlighted with a unique Bar & Shield logo, these easy-to-install billet-look covers hide the Original Equipment fork and steering stem hex-head hardware and add a clean custom touch to the top of the triple tree. Available in your choice of chrome or gloss black finish, the kit comes complete with three covers and mounting hardware.

45800015 Gloss Black. **\$59.95**
Fits '06-later Dyna® models (except FLD, FXDB and FXDSE/2).

46109-06 Chrome. **\$59.95**
Fits '06-later Dyna models (except FLD, FXDB and FXDSE/2).

46129-98B Chrome. **\$59.95**
Fits '86-later FLSTC, '90-later FLS, FLSTF, '95-'05 FXD, '93-'05 FXDL, '94-'05 FXDS-CONV. and '88-'13 XL models (except XL Custom and XL1200S models.).

45002-98 Chrome. **\$59.95**
Fits '00-later FXST, FXSTB, FXSTD, '86-later FXSTC and '93-'05 FXDWG models.



A. UPPER FORK NUT COVERS – GLOSS BLACK

B. TRIPLE TREE KIT – GLOSS BLACK

The classic Harley-Davidson color is black. It shows your attitude, your feelings and your desire to be different from the rest. This gloss black Triple Tree is the ultimate extension of the Harley-Davidson philosophy. Manufactured from Original Equipment components to ensure superior fit and finish, this gloss black Triple Tree complements the black fork sliders and the handlebar risers featured on the Dyna® Fat Bob® model. Add the matching Black Handlebar P/N 55977-09 for a complete blacked-out look.

48609-09 **\$279.95**
Fits '08-later FXDF and FXDFSE/2 models.



A. UPPER FORK NUT COVERS – CHROME



B. TRIPLE TREE KIT – GLOSS BLACK

Notice: The prices appearing in this catalog are the manufacturer's suggested retail prices. Actual retail prices may vary.



C. TRIPLE TREE KIT – CHROME



D. CLASSIC CHROME STEERING STEM BOLT COVER KIT

C. TRIPLE TREE KIT – CHROME

Drape your front end in chrome. The ideal complement to chrome fork sliders, this beautifully polished and plated Triple Tree is manufactured from Original Equipment components to ensure quality and fit. The kit includes chrome hardware and fork stem installed in lower tree.

45023-02 **\$279.95**
Fits '90-'05 FXD, FXDL, FXDS-CONV. and FXDX models.
Requires separate purchase of Bearing P/N 48300-60.

D. CLASSIC CHROME STEERING STEM BOLT COVER KIT

For a finished appearance of the upper fork clamp on all models with 39mm forks.

48329-90A **\$39.95**
Fits XL, '91-'05 Dyna® and FXR models with 39mm forks.
(Does not fit FXDWG.)

E. FRONT FENDER TRIM

Add a sweeping dash of chrome to the front fender. Chrome-plated tapered spear features a stepped design that accentuates the flowing fender lines. Self-adhesive backing simplifies installation.

14100618 **\$44.95**
Fits Dyna FLD, FL Softail® and Touring and Trike models with full front fender.

F. BAR & SHIELD LOGO FRONT FENDER SPEAR

This chrome-plated trim spear adds a sweeping dash of chrome to the front fender. Featuring a raised Bar & Shield logo set against a textured black field, this self-adhesive medallion is easy to install.

91194-04 Small **\$39.95**
Fits XL, XR, Dyna (except FLD) and FX Softail models.

G. FRONT FENDER EXTENSION – CHROME

Dress your front fender in chrome. This chrome-plated tapered Fender Extension is shaped to follow the curve of the fender for style and function. Using the Original Equipment fender hole, the extension mounts below the trailing edge of the fender to help control road dirt and spray.

59664-03 **\$49.95**
Fits '91-'08 Dyna and '84-'07 FX Softail models. Will not fit FXD, FXDX or FXDXT models equipped with Voltage Regulator Covers.

H. FRONT FENDER HARDWARE KIT – CHROME

Finish the show-winning look with brilliant chrome hardware. Manufactured to Original Equipment specifications, this kit replaces the zinc-plated exposed front fender mounting bolts with chrome-plated socket head cap screws.

94415-05 **\$9.95**
Fits '91-later Softail models (except Springer™, FXCW, FXCWC, FXSB, FXSBSE and FXSTD) and '93-'05 FXDWG models. Does not fit with Billet Fork Sliders or Inverted Front End Kit.



E. FRONT FENDER TRIM



F. BAR & SHIELD LOGO FRONT FENDER SPEAR

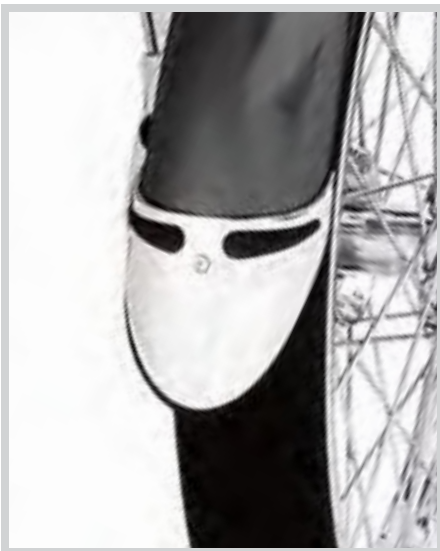

G. FRONT FENDER EXTENSION – CHROME



H. FRONT FENDER HARDWARE KIT – CHROME

Notice: The prices appearing in this catalog are the manufacturer's suggested retail prices. Actual retail prices may vary.

194 DYNA®

Chassis Trim – Rear End

A. SWINGARM – CHROME

The ultimate chrome accessory, polished to the highest standard using bright plating to complement Original Equipment finishes. Affordable and convenient, with no troublesome exchanges necessary. Factory specifications guarantee exact fitment, unparalleled quality and an affordable price. Stamped with the Harley-Davidson logo.

48458-10 Fits '10-later Dyna® models. **\$369.95**

48458-06 Fits '06-'09 Dyna models. **\$399.95**

B. REAR WHEEL SPACER KIT – CHROME

Add some chrome detail to an often overlooked area of the bike with this highly polished Chrome Wheel Spacer Kit. Manufactured to the Original Equipment tolerances, to ensure product fitment and quality.

41362-08 Tapered. **\$34.95**

Fits '08-later Dyna models without ABS.

C. EXHAUST MOUNTING BRACKET – CHROME

Replace the stock black bracket with this brilliantly chrome-plated piece. Manufactured from Original Equipment components for precise fit, this Exhaust Bracket complements both chrome and jet black exhaust systems.

80871-10 **\$69.95**

Fits '08-later FXDF and '10-later FXDWG models.



A. SWINGARM – CHROME
(SHOWN WITH CHROME UPPER AND LOWER BELT GUARDS)



A. SWINGARM – CHROME



B. REAR WHEEL SPACER KIT – CHROME



C. EXHAUST MOUNTING BRACKET – CHROME

Notice: The prices appearing in this catalog are the manufacturer's suggested retail prices. Actual retail prices may vary.

DYNA® 195

Chassis Trim – Rear End



D. CHROME UPPER AND LOWER BELT GUARDS – ('07-LATER STYLE SHOWN)



D. CHROME UPPER AND LOWER BELT GUARDS – ('00-'05 STYLE SHOWN)



E. SLOTTED UPPER BELT GUARD – CHROME

D. UPPER BELT GUARD – CHROME

Hand-polished and chrome-plated to replace your factory-equipped black upper belt guard.

60303-07 Fits '07-later Dyna® models (except FXDF and FXDFSE/2). **\$109.95**

60303-06 Fits '06 Dyna models. **\$109.95**

60293-00 Fits '00-'05 Dyna models. **\$159.95**

Shown with:

LOWER BELT GUARD COVER – CHROME

Designed to cover the Original Equipment black lower debris deflector, this mirror-chrome finished cover adds an exceptional finish to the rear drive components. Kit includes required mounting hardware.

60514-07A Fits '07-later Dyna models. **\$64.95**

60489-06A Fits '06 Dyna models. **\$64.95**

60475-92A Fits '91-'05 Dyna models and all '94-'99 International Dyna models equipped with 70- or 65-tooth sprockets. **\$64.95**

E. SLOTTED UPPER BELT GUARD – CHROME

Designed to add a unique and stylish look, the hand-polished and chrome-plated Slotted Belt Guard opens up the left side of the bike for an aggressive profile. Easy to install, the Slotted Guard replaces the stock painted unit and includes chrome-plated mounting hardware.

60711-07 Fits '07-later Dyna models (except FXDF and FXDFSE/2). **\$109.95**

Stock on '07-'08 FXDSE models.

DYNA

Notice: The prices appearing in this catalog are the manufacturer's suggested retail prices. Actual retail prices may vary.

196 DYNA®

Chassis Trim – Rear End

A. LOW-PROFILE REAR AXLE COVERS

This Low-Profile Rear Axle Cover is contoured to accent the tail end of the swingarm. Designed to conceal both the rear axle nut and the adjusting hardware, the smooth chrome surface and sleek hidden fasteners complement either an Original Equipment black or accessory chrome swingarm. This easy-to-install kit includes all required installation hardware.

47645-09 \$134.95

Fits '08-later Dyna® models. Original Equipment on '10 FXDFSE models. Will not fit models equipped with saddlebags.



A. LOW-PROFILE REAR AXLE COVERS



B. "HARLEY-DAVIDSON" SCRIPT REAR AXLE COVERS

B. "HARLEY-DAVIDSON" SCRIPT REAR AXLE COVERS

Chrome-plated die-cast cover conceals the side of the swingarm and the axle. Unique styling features a black-filled embossed "Harley-Davidson" script for a distinctive contrast. The kit is easy to install without removing the rear wheel. Kit includes all necessary mounting hardware.

44346-06 \$74.95

Fits '06-later Dyna models. Will not fit models equipped with saddlebags.

C. REAR AXLE NUT COVERS

Cover your rear axle nut in the most traditional way. These Rear Axle Cover Kits complement the matching Front Axle Nut covers. Easy to install, these cover kits include necessary mounting hardware. Sold in pairs.

Classic Chrome – Billet

43132-08 \$42.95

Fits '08-later Dyna and Softail® models (except FXCW, FXCWC, FXSB, FXSBSE and FXST-Aus).

Classic Chrome – Die-cast

41705-09 \$27.95

Fits '08-later Dyna and Softail models (except FXCW, FXCWC, FXSB, FXSBSE and FXST-Aus).

42034-07 \$27.95

Fits '06-'07 Dyna models.

44262-01 \$27.95

Fits '91-'05 Dyna models.

Gloss Black

43422-09 \$42.95

Fits '08-later Dyna and Softail models (except FXCW, FXCWC, FXSB, FXSBSE and FXST-Aus).

Willie G Skull Collection

41706-09 \$34.95

Fits '08-later Dyna and Softail models (except FXCW, FXCWC, FXSB, FXSBSE and FXST-Aus).

42064-07 \$29.95

Fits '06-'07 Dyna models.

"H-D Motor Co." Logo

41704-09 \$29.95

Fits '08-later Dyna and Softail models (except FXCW, FXCWC, FXSB, FXSBSE and FXST-Aus).

42065-07 \$29.95

Fits '06-'07 Dyna models.

44257-01 \$29.95

Fits '91-'05 Dyna models.



C. REAR AXLE NUT COVERS – CLASSIC CHROME



C. REAR AXLE NUT COVERS – GLOSS BLACK



C. REAR AXLE NUT COVERS – WILLIE G SKULL COLLECTION



C. REAR AXLE NUT COVERS – "H-D MOTOR CO." LOGO

D. SHOCK BOLT COVERS

It's the details that complete the look of your bike. These Shock Bolt Covers are designed to hide the upper shock mounting hardware and provide a custom look to the rear of your bike. Easy-to-install, the kit includes left and right bolt covers and all required mounting hardware.

Fits '04-later XL and '06-later Dyna models (except FLD, FXDF and FXDL). Does not fit with H-D® Detachables™ Leather Saddlebag Kit P/N 90181-08A.

54000016 Chrome. \$39.95

54000017 Gloss Black. \$39.95



D. SHOCK BOLT COVERS – CHROME



D. SHOCK BOLT COVERS – GLOSS BLACK

Notice: The prices appearing in this catalog are the manufacturer's suggested retail prices. Actual retail prices may vary.

DYNA® 197

Chassis Trim – Rear End



E. REAR FENDER SUPPORT COVER KIT – GLOSS BLACK

E. REAR FENDER SUPPORT COVER KIT – GLOSS BLACK

Manufactured from Original Equipment components to ensure superior fit and finish, the gloss black Fender Strut Covers conceal the cast fender struts and continue the dark look to the back of the bike. The ideal finishing touch for your "blacked-out" Fat Bob®, these covers are the perfect complement to available gloss black Passenger Sissy Bars and Luggage Racks.

59473-09 **\$129.95**
Fits '08-later FXDF and FXDFSE/2 models.

F. SIDE-MOUNT LICENSE PLATE KIT

Add a clean, custom look to the rear fender. This stylish kit moves the license plate from the fender to a side-mount location, visually lowering the bike's profile and opening up the view of the rear end. This strut-mounted hinged frame conceals the license mounting hardware and features a smooth back that hides the unfinished side of the plate. Kit includes LED license plate illumination and a curved Bar & Shield medallion, shaped to conceal the original license mounting holes in the fender. Purchase of tail lamp without license illumination window is recommended for models with center-mounted tail lights.

NOTE: License plate location and fold-away feature is regulated in many states. Check state and local laws before installation.

Fits '06-later Dyna® models (except FLD, FXDF, FXDWG and FXDFSE/2). Will not fit models equipped with rigid mount saddlebags, rigid mount sissy bars and Turn Signal Relocation Kit P/N 68732-02A and 68733-02A.

60938-10	Chrome.	\$199.95
60978-10	Gloss Black.	\$199.95

G. BOBTAIL REAR FENDER KIT*

Change the look and the attitude of your Dyna motorcycle with a Bobtail Rear Fender. Standard on the Dyna Wide Glide® model. This sleek upturned fender adds style to the rear of your bike.

Fits '06-later FXD, FXDC, FXDL, '14-later FXDF and '06-'08 FXDB models. FXDF requires separate purchase of tail light assembly. Stock on '06-'08 FXDWG models. Does not fit '08-'13 FXDF, FXDFSE/2, '10-later FLD and FXDWG models. Requires separate purchase of Installation Kit P/N 69710-06.

59925-06	Primed.	\$299.95
59925-06DH	Vivid Black.	\$399.95

Also available:

BOBTAIL REAR FENDER INSTALLATION KIT

Required for installation of Bobtail Fender Kit on Dyna models.

69710-06 **\$249.95**
Fits '06-later FXD, FXDC, FXDL, '14-later FXDF and '06-'08 FXDB models. Stock on '06-'08 FXDWG models.



F. SIDE-MOUNT LICENSE PLATE KIT – CHROME



F. SIDE-MOUNT LICENSE PLATE KIT – GLOSS BLACK



G. BOBTAIL REAR FENDER KIT – VIVID BLACK

Notice: The prices appearing in this catalog are the manufacturer's suggested retail prices. Actual retail prices may vary.

198 DYNA®

Chassis Trim – Brakes

A. BRAKE BLEEDER AND BANJO BOLT COVERS

1. Brake Bleeder Screw Cover

This cover adds chrome to the unfinished bleeder valve on stock H-D® calipers. Package of two.

43834-98 **\$23.95**

Fits '84-later stock calipers (except XR models).

2. Chrome Banjo Bolt Cover

Die-cast chrome cover provides a custom look to your stock banjo bolts. Fits banjo bolts on front and rear brake master cylinders and front and rear calipers. Installs in seconds.

32715-98 **\$21.95**

Fits '84-later models with stock master cylinders and calipers. (Does not fit VRSC™ Rear Master Cylinder, '06-later VRSC calipers, '08-later Touring or '04-later XL models.)



A. BRAKE BLEEDER AND BANJO BOLT COVERS

B. BANJO BOLT KIT – CHROME

Replace the Original Equipment 12-point zinc finish brake line hardware with brilliant chrome custom tapered banjo bolts.

41842-06 **\$29.95**

Fits '91-'03 XL, '91-later Dyna® (except FXDF), '95-'14 Softail® and '99-'00 FXR models equipped with single front brake. Does not fit on the Dyna or Softail ABS Hydraulic Control Unit. Does not fit with Banjo Bolt Cover P/N 32715-98. Kit includes one .4375" banjo bolt, three .375" banjo bolts and eight sealing washers.

C. WIDE TIRE KIT – DYNA MODELS

Add the wide tire look to your '06-later Dyna model. The 180mm rear tire fills out the rear fender to add a menacing look from the back. A simple conversion at your first tire change, the kit includes the DUNLOP® GT502 180/60B17 rear tire and the required installation brackets and hardware. This easy-to-install kit fits with the Original Equipment 17.0" wheel and requires no frame or powertrain alterations.

43779-09 **\$399.95**

Fits '09-'12 FXDB models. Use with '10-'12 FXDB requires separate purchase of DUNLOP front tire. Use with saddlebag kits requires separate purchase of two Fender Mounting Brackets P/N 60181-09 (not required when used with Docking Hardware Kit P/N 53797-09).

43705-06 Fits '06-'08 FXDWG models. **\$399.95**

43768-06 **\$399.95**

Fits '06-later Dyna models (except FLD, FXDWG, FXDF, FXDSE/2, FXDFSE/2 and '09-later FXDB). '10-later Dyna models require separate purchase of DUNLOP front tire. Installation of Rigid Sideplate Kit P/N 52856-06 on models without saddlebags requires separate purchase of Hardware Kit P/N 53975-06. Installation of H-D® Detachables™ Sideplate Kit P/N 52866-06 on models without saddlebags requires separate purchase of Hardware Kit P/N 53974-06.



B. BANJO BOLT KIT – CHROME

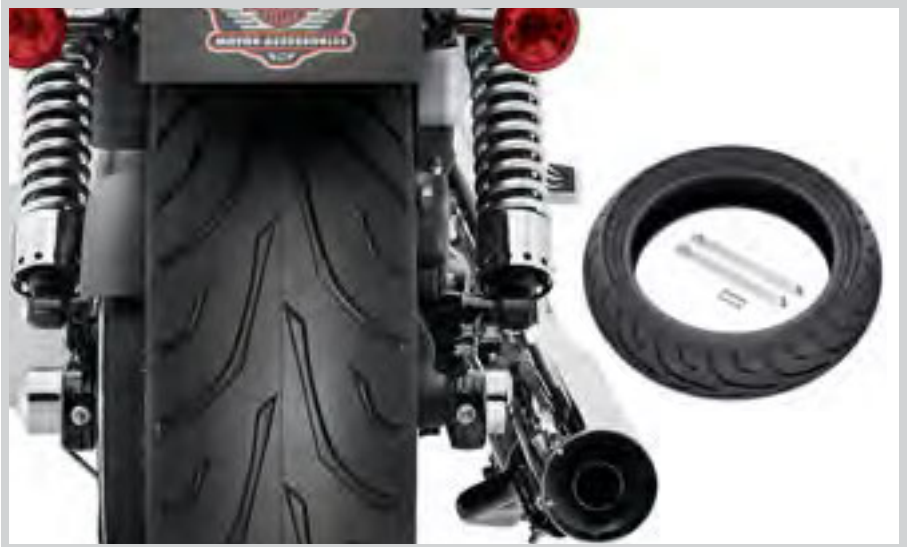

C. WIDE TIRE KIT – DYNA MODELS (STREET BOB SHOWN)

Notice: The prices appearing in this catalog are the manufacturer's suggested retail prices. Actual retail prices may vary.



D. SPROCKET COVER – CHROME



D. SPROCKET COVER – CHROME

D. SPROCKET COVER – CHROME

This sprocket cover gives the appearance of a chrome sprocket at a fraction of the cost. It matches the styling of the Original Equipment sprocket and bolts on using the Original Equipment hardware.

37756-07 **\$49.95**
Fits '07-later Dyna® models (except FLD).

E. TYPHOON SPROCKET COVER

Styled to match the distinctive Typhoon Custom Wheel. Available in mirror-chrome or gloss black, this Sprocket Cover gives the appearance of having a custom sprocket at a fraction of the cost. Cover easily bolts on using the stock hardware or for a finished look, add the Chrome Hardware Kit P/N 94773-07 (sold separately).

Fits '07-later Dyna models.
40142-08 Chrome. **\$49.95**
42200012 Gloss Black. **\$49.95**



E. TYPHOON SPROCKET COVER – CHROME



E. TYPHOON SPROCKET COVER – GLOSS BLACK

F. MAGNUM 5 SPROCKET COVER

Styled to match the distinctive Magnum 5 Custom Wheel. Available in mirror-chrome or gloss black, this Sprocket Cover gives the appearance of having a custom sprocket at a fraction of the cost. Cover is easy to install with Original Equipment hardware or add the Chrome Hardware Kit P/N 94773-07 (sold separately) for a finished look.

Fits '07-later Dyna models (except FLD).
40120-09 Chrome. **\$54.95**
42200010 Gloss Black. **\$54.95**

G. SPROCKET COVER WITH HOLES – CHROME

Chrome sprocket cover matches the styling of the Original Equipment sprocket. Gives the appearance of having a chrome sprocket at a fraction of the cost.

91346-00 70-Tooth Sprocket. **\$49.95**
Fits '00-'05 Dyna models.

91733-85A 70-Tooth Sprocket. **\$54.95**
Fits '91-'99 Dyna models. Also fits '80-'99 Domestic 1340 models except '93 and '95-'99 Softail® models. '94 Domestic Softail models are equipped with 70-tooth rear sprockets. Also fits all '94-'99 International 1340 models (except International Softail and Swiss 1340 models).

H. SPROCKET HARDWARE – CHROME HEX HEAD

This kit includes highly-polished, chrome-plated, grade 8 hex-head screws with chrome-plated washers, providing an extra custom accent. The perfect addition to the new chrome sprocket. Made from the same Original Equipment bolts to ensure product integrity. Also works with chrome belt sprocket covers and Original Equipment sprockets.

94773-07 **\$29.95**
Fits '07-later Dyna and Softail models.
94773-00A **\$29.95**
Fits '00-'06 Softail and '00-'05 Dyna models.
94708-98 **\$29.95**
Fits '93-'99 Softail, '93-'99 Dyna and '91-later XL models.



F. MAGNUM 5 SPROCKET COVER – CHROME



F. MAGNUM 5 SPROCKET COVER – GLOSS BLACK



G. SPROCKET COVER WITH HOLES – CHROME



H. SPROCKET HARDWARE – CHROME HEX HEAD



Notice: The prices appearing in this catalog are the manufacturer's suggested retail prices. Actual retail prices may vary.

DYNA