

Copie Privée

SPORTSTER 59

GENUINE MOTOR PARTS & ACCESSORIES



2015

SPORTSTER®

Since 1957, Sportster® motorcycles have set the standard for the no-nonsense pursuit of two-wheeled freedom and adventure. Today, they are available in more distinct looks than ever, to give you a running start on building your own unique machine.



Handlebar height is regulated in many areas. Check local laws before installing.

FORUM P-H



SPORTSTER®

SUPERLOW®

XL883L | PRODUCTION COLOR: VIVID BLACK

This 883 SuperLow® model is as easy on the eyes as it is to ride. The blacked-out Screamin' Eagle® air cleaner and exhaust, fork sliders, and mini-wind deflector complement the Vivid Black paint and hard saddlebags. And the Reduced Reach Solo Seat and further forward mid foot controls give you more room to maneuver this light and agile motorcycle.



SEE WHAT'S ON THIS BIKE AT [H-D.COM/GALLERY](https://www.harley-davidson.com/gallery)



SPORTSTER®

IRON 883™

XL883N | PRODUCTION COLOR: HARD CANDY QUICKSILVER FLAKE

Ride the line between no-nonsense bobber and cool café racer with this muscular ride. Black Ice Machete wheels and red brake calipers stand out against the contrast cut Burst Collection controls, while the Screamin' Eagle® Stage I air cleaner and Street Cannon mufflers add the thrust to keep you plastered against the metal flake solo seat.



SPORTSTER®

1200 CUSTOM

XL1200C | PRODUCTION COLOR: BRILLIANT SILVER/VIVID BLACK

Some looks never go out of style. From the sparkling hand controls to the Daymaker™ LED headlamp, and from the Machete wheels to the tip of the Street Cannon mufflers, chrome is king on this two-tone beauty. But it's not only about style – the two-up Rallyrunner® seat and the sissy bar backrest cradle you and your passenger in luxury and comfort.



SEE WHAT'S ON THIS BIKE AT [H-D.COM/GALLERY](https://www.harley-davidson.com/gallery)





SPORTSTER®

SUPERLOW® 1200T

XL1200T | PRODUCTION COLOR: DEEP JADE PEARL / VIVID BLACK

Stretch your legs on the Mustache engine guard, and eat up the miles on this luxurious motorcycle. The windshield and saddlebags are ready for touring and the Reduced Reach solo seat, quick-release rider backrest and Circulator seat pad add comfort for the long haul. Finish it off with abundant chrome touches that show your personal style.



SEE WHAT'S ON THIS BIKE AT [H-D.COM/GALLERY](https://www.harley-davidson.com/gallery)



SPORTSTER®

SEVENTY-TWO®

XL1200V | PRODUCTION COLOR: BLACK QUARTZ

A few key mods are all it takes to turn this Seventy-Two® model into a long, low hot rod. The rolled-down Drag Bar puts riders in a café racer position. The distressed leather and brass rigid-mount Bobber Solo Saddle takes “minimal” to a new level, and the narrow whitewall tires and retro Smooth Air Cleaner Cover add a nostalgic touch.





SPORTSTER®

FORTY-EIGHT®

XL1200X | PRODUCTION COLOR: HARD CANDY BIG RED FLAKE

The first thing you notice on this Forty-Eight® model is the eye-popping Hard Candy Big Red Flake paint on the classic "peanut" gas tank. But don't miss the edgy Chizeled bars*, Burst Collection foot controls, and the white piping on the Black Diamond Solo Spring Saddle that add a bit of flair and anchor the bike in old-school cool.



SEE WHAT'S ON THIS BIKE AT [H-D.COM/GALLERY](https://www.harley-davidson.com/gallery)

*Handlebar height is regulated in many areas. Check local laws before installing.

SEVENTY-TWO® TRANSFORMATION

With an authentic '70s chopper attitude, Hard Candy Custom™ paint, and loads of chrome, the Seventy-Two® model rolls off the factory floor as a low-rider-inspired radical custom.

CUSTOM CLASSIC

We've taken this custom Seventy-Two® motorcycle even deeper into a classic era with a number of well-chosen enhancements. Taking their cues from the stock whitewall tires, nostalgic white hand grips and the White Diamond Solo Saddle set a decidedly retro tone. The black piping

gives this classic seat a striking look, while its external springs soften the ride. The chrome Chizeled handlebar*, low-set Tribal mirrors and the chrome swingarm complete the profile, while the Screamin' Eagle® Street Cannon slip-on mufflers boost performance to thoroughly modern levels.



WHITE DIAMOND
SOLO SPRING SADDLE

CHROME SWINGARM
& AXLE COVERS

SCREAMIN' EAGLE®
STREET CANNON MUFFLERS



FIT

Parts list available at h-d.com/gallery

The Chizeled handlebar* provide an upright "fists in the wind" riding posture with a '70s lane-splitting narrow profile. For a clean, custom look, the "Z" bar features cast mitered corners for easy internal wiring.



FUNCTION

Cool can be practical. Equipped for a run to the pool hall or for a night on the town, this narrow and nimble ride is perfect for squeezing through traffic. Add a swingarm bag, and you can stash your stuff in style.



STYLE

With its smooth metal seat pan and simple frame cover, the Solo Spring Saddle delivers a clean, finished old-school look—without any frame cutting or modifications. So you can always install a traditional two-up seat when you want to take someone along for the ride.



PERFORMANCE

The Screamin' Eagle® Street Cannon slip-on mufflers provide free flow of exhaust gases with just the right amount of back pressure for a smooth-running ride, an exhaust note with extra deep bass, and performance you can feel.





*Handlebar height is regulated in many areas. Check local laws before installing.



CARE AND MAINTENANCE

While it's tempting to use standard "auto parts store" cleaning and service supplies, hold out for the real thing. Genuine Harley-Davidson® coolant, oils, filters, batteries and service parts are engineered for the unique surfaces and operating conditions your Harley® motorcycle will encounter.



CHIZELED BAR & CUSTOM HAND CONTROLS



SCREAMIN' EAGLE® STREET CANON MUFFLERS



CRAFTSMANSHIP

We design and build the bikes, so we don't need to "reverse-engineer" parts to try and make them fit. Everything we make is rigorously tested to ensure it meets our high standards, and the finishes of our accessories match the bike's surfaces for a consistent appearance.



CHROME SWINGARM, AXLE COVER & POLISHED ROTOR



WHITE DIAMOND SOLO SPRING SADDLE

74 SPORTSTER®

Windshields

A. COMPACT SPORT WIND DEFLECTOR

Shaped to smooth the wind flow around the headlamp and handlebar mount gauges, this compact bikini screen is the ideal addition to your ride. Sitting just above the headlamp, the Compact Wind Deflector maintains the stripped-down minimalist attitude of the Sportster motorcycle while adding a clean, custom look. The easy-to-install dark polycarbonate screen attaches to the fork tubes with chrome-plated adjustable clamps. Kit includes all mounting hardware.

57400184 **\$249.95**

Fits '04-later XL models (except '11-later XL1200C).



A. COMPACT SPORT WIND DEFLECTOR

B. SPORT WINDSHIELD KIT

Formed of polycarbonate and hard-coated to resist scratching. Light smoke windshield is contoured to fit the headlamp and incorporates adjustable four-point mounting. Functional styling helps deflect wind to reduce upper body fatigue.

58192-87A 17" Light Smoke. **\$164.95**

Fits '88-later XL (except XL Custom, XL1200T, XL1200X and '11-later XL883L) and '95-'05 Dyna® models (except FXDWG and FXDXT). Includes black mounting hardware. Windshield dimensions: Overall height – 18.5"; width – 16.3".

58024-96A 17" Light Smoke. **\$174.95**

Fits '96-'10 XL Custom, XL1200X and '87-'94 FXLR models. Also fits '99-'00 FXR models. Windshield dimensions: Overall height – 19.1"; width – 16.3".



B. SPORT WINDSHIELD KIT –
(58192-87A SHOWN)



B. SPORT WINDSHIELD KIT –
(58024-96A SHOWN)

C. QUICK-RELEASE SUPER SPORT WINDSHIELD

Reduces the pounding of wind and shower of bugs but keeps the wind-in-the-hair feeling. Ideal for a cool morning ride, the sleek profile of the Super Sport Windshield hugs the front headlamp for a sporty look. The windshield mounts to the fork tubes with elegant die-cast lever locking clamps, so the windshield does not require any "leave-behind" docking hardware. You get quick on-and-off convenience and a clean, custom look. No tools are required and the kit includes everything needed to install the windshield.

Fits '08-'13 XR1200™ models.

57262-08 11" Gradient. **\$344.95**

Windshield dimensions: Overall height – 13.8"; width – 12.8".

57260-08 13" Light Smoke. **\$344.95**

Windshield dimensions: Overall height – 18.7"; width – 13.8".



C. QUICK-RELEASE SUPER SPORT
WINDSHIELD – 11"



C. QUICK-RELEASE SUPER SPORT
WINDSHIELD – 13"

Notice: The prices appearing in this catalog are the manufacturer's suggested retail prices. Actual retail prices may vary.



D. QUICK-RELEASE SUPER SPORT WINDSHIELD

**D. QUICK-RELEASE SUPER SPORT WINDSHIELD**

Reduces the pounding of wind and shower of bugs, but keeps the wind-in-the-hair feeling. Ideal for a cool morning ride, the sleek profile of the Super Sport Windshield hugs the front headlamp for a sporty look. The windshield mounts to the fork tubes with elegant die-cast lever locking clamps, so the windshield does not require any "leave-behind" docking hardware. You get quick on-and-off convenience and a clean, custom look. No tools are required and the kit includes everything needed to install the windshield.

57838-08 19" Light Smoke. **\$324.95**

Fits '88-later XL (except XL1200T, XL1200X, '11-later XL883L and XL1200C) and '91-'05 Dyna® models (except FXDWG and FXDXT). XL Custom models require Front Directional Relocation Kit P/N 68517-94A. Windshield dimensions: Overall height – 25.0"; width – 20.1".

E. QUICK-RELEASE COMPACT WINDSHIELD

Combine the classic Harley-Davidson® windshield shape with a revolutionary new attachment system and you have the best of style and function. The windshield mounts to the fork tubes with elegant die-cast lever-release clamps, so the windshield does not require any "leave-behind" docking hardware. You get quick on-and-off convenience and a clean, custom look. No tools are required and the kit includes everything needed to install the windshield. The tough, hard-coated polycarbonate windshield is available with traditional polished or gloss black horizontal and vertical braces.

Fits '88-later XL (except XL1200T, XL1200X, '11-later XL883L and XL1200C) and '91-'05 Dyna models (except FXDWG and FXDXT).

58063-04 18" Clear – Polished Braces. **\$369.95**

Windshield dimensions: Overall height – 26.8"; width – 19.7".

58706-09 18" Clear – Black Braces. **\$389.95**

Windshield dimensions: Overall height – 26.8"; width – 19.7".

58601-04 18" Light Smoke – Polished Braces. **\$399.95**

Windshield dimensions: Overall height – 26.8"; width – 19.7".

58602-04 14" Light Smoke – Polished Braces. **\$389.95**

Windshield dimensions: Overall height – 22.8"; width – 19.5".

58703-09 14" Light Smoke – Black Braces. **\$419.95**

Windshield dimensions: Overall height – 22.8"; width – 19.5".

Fits '14-later XL1200T and '11-later XL883L and XL1200C models.

57801-11 18" Clear – Polished Braces. **\$369.95**

Windshield dimensions: Overall height 26.8"; width 19.7".

57802-11 14" Light Smoke – Polished Braces. **\$379.95**

Windshield dimensions: Overall height 22.8"; width 19.5".

Fits '10-later XL1200X models.

58053-10 19" Clear – Black Braces. **\$369.95**

Windshield dimensions: Overall height 24.0"; width 19.5".

57682-10 15" Light Smoke – Black Braces. **\$389.95**

Windshield dimensions: Overall height 20.0"; width 19.5".

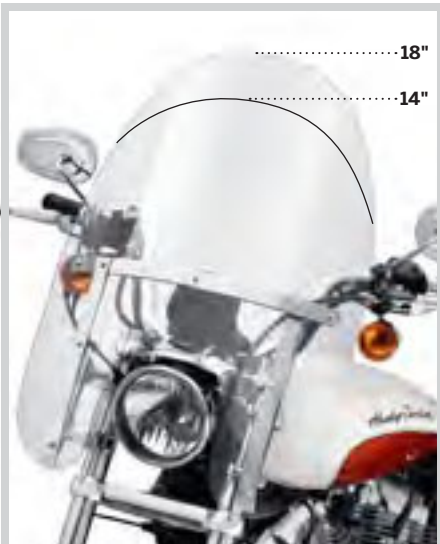

E. QUICK-RELEASE COMPACT WINDSHIELD – POLISHED BRACES



E. QUICK-RELEASE COMPACT WINDSHIELD – GLOSS BLACK BRACES



76 SPORTSTER®

Windshields

A. H-D® DETACHABLE COMPACT WINDSHIELD FOR MODELS WITH AUXILIARY LIGHTING

Whether it's for keeping bugs off your face or warmth in your body, a windshield has a huge impact on rider and passenger comfort. By diverting air pressure past your chest and over your helmet, a windshield can add hours of riding comfort. This high-quality polycarbonate windshield mounts to the fork tubes with detachable Docking Hardware for easy on-and-off convenience and a quick return to a stripped-down profile and is shaped to fit models equipped with Auxiliary Lighting Kits.

57400053 18" Clear. **\$289.95**

Fits '11-later XL883L models. Also for use on '11-later XL883L Police models equipped with pursuit lamps. Requires the separate purchase of Docking Hardware Kit P/N 58164-96A and Turn Signal Relocation Kit P/N 68603-01. Windshield dimensions: Overall height – 22.7"; width – 19.5".

57716-01 18" Clear. **\$289.95**

Fits '88-later XL (except XL1200T, XL1200X, '11-later XL883L and XL1200C) and '91-'05 Dyna® models (except FXDWG and FXDXT) equipped with Auxiliary Lamps. Requires the separate purchase of Docking Hardware Kit P/N 58164-96A and Turn Signal Relocation Kit P/N 68603-01. Windshield dimensions: Overall height – 26.8"; width – 19.7".



A. H-D DETACHABLES COMPACT WINDSHIELD FOR MODELS WITH AUXILIARY LIGHTING

B. VENTILATOR QUICK-RELEASE COMPACT WINDSHIELD

In a nutshell, a windshield should provide a barrier between the rider and errant bugs, discarded cigarette butts, flying debris and bad air. The shield should manage airflow and wind blasts to create a pocket of still air for both rider and passenger comfort. But if you ride in a warm climate or spend time at low speeds stuck in traffic, you need to keep some air circulating around your body to stay comfortable. The Ventilator Windshield features clear injection molded vents that allow you to adjust the airflow to match the riding conditions. Opening the vents redirects the air across your chest for a cooling effect and closing the vents provides maximum wind and weather protection. But when you want to ride "naked," the detachable shield can be removed completely and re-installed in seconds to match your riding mood.

57400025 19" Clear. **\$429.95**

Fits '88-later XL (except XL1200T, XL1200X, '11-later XL883L and XL1200C) and '91-'05 Dyna models (except FXDWG and FXDXT). Windshield dimensions: Overall height – 28.0"; width – 21.4".



B. VENTILATOR QUICK-RELEASE COMPACT WINDSHIELD

B. VENTILATOR QUICK-RELEASE COMPACT WINDSHIELD — OPEN

C. QUICK-RELEASE TOURING WINDSHIELD

The Touring Windshield features an aerodynamic design shaped to provide hours of riding comfort. The additional center width directs airflow past the hand grips and deflects rain and road debris around the rider. The windshield mounts to the fork tubes with elegant die-cast lever-release clamps, so the windshield does not require any "leave-behind" docking hardware. You get quick on-and-off convenience and a clean, custom look. No tools are required and the kit includes everything needed to install the windshield. The tough, hard-coated polycarbonate windshield features traditional chrome horizontal and vertical braces.

58158-08 19" Clear. **\$439.95**

Fits '88-later XL (except XL1200T, XL1200X, '11-later XL883L and XL1200C) and '91-'05 Dyna models (except FXDWG and FXDXT). Windshield dimensions: Overall height – 28.3"; width – 22.1".



C. QUICK-RELEASE TOURING WINDSHIELD



D. H-D DETACHABLES QUARTER FAIRING KIT



E. HEADLAMP VISOR



F. FRONT DIRECTIONAL RELOCATION KIT



G. LOCKING QUICK-RELEASE WINDSHIELD CLAMP



H. DOCKING HARDWARE FOR H-D DETACHABLES WINDSHIELDS



I. WINDSHIELD ACORN NUT KIT

D. H-D® DETACHABLES™ QUARTER FAIRING KIT

Sleek, racy styling and sweeping lines are the make-up of this innovative fairing. Its quarter-sized, detachable design gives your bike a whole new, sporty look that can be changed in an instant. Available in Primed or Vivid Black. Requires the installation of Detachable Docking Hardware Kit P/N 58164-96A.

Fits '88-later XL (except XL Custom, XL1200X, XL1200N, XL1200T, XL883N and '11-later XL883L), FXR and '95-'05 Dyna® models (except FXLR, FXDXT and FXDWG).

57070-98	Primed.	\$279.95
57070-97DH	Vivid Black.	\$399.95

E. HEADLAMP VISOR

Add an element of racy style to stock headlamps with these visors, available in Primed or Vivid Black.

Fits '95-later XL models (except XL Custom, XL1200V and XL1200X), '95-'05 Dyna models (except FXDWG and FXDXT), '82-'94 FXR and FXRS models.

68129-97	Primed.	\$119.95
68129-98DH	Vivid Black.	\$229.95

F. FRONT DIRECTIONAL RELOCATION KIT

This kit includes the required hardware and wiring to move the front directional lamps from the handlebar to the lower triple clamp.

Fits '88-later XL (except XL1200T, XL1200X, '11-later XL883L and XL1200C) and '91-'05 Dyna models (except FXDWG and FXDXT).

68517-94A	Chrome.	\$39.95
68643-09	Gloss Black.	\$34.95

G. LOCKING QUICK-RELEASE WINDSHIELD CLAMP

Protect your investment. This Locking Quick-Release Windshield Clamp secures your windshield from grab-and-run theft, giving you peace of mind when you have to leave your bike unattended. The chrome-plated Locking Clamp replaces one of the Original Equipment windshield clamps and features a push-button lock with a mini barrel-style key for easy removal. Kit includes one locking clamp and two matching keys.

57400006 39mm. **\$39.95**
Fits '88-later XL and '91-'05 Dyna models (except FXDWG) equipped with Quick-Release Style detachable windshields.

H. DOCKING HARDWARE FOR H-D DETACHABLES WINDSHIELDS

Each kit includes polished clamps and all required mounting hardware.

58164-96A **\$79.95**
Required for installation of H-D® Detachables™ windshields on '88-later XL (except XL1200X and '11-later XL1200C) and '91-'05 Dyna models (except FXDWG and FXDXT). XL and Dyna models with front turn signals originally located on the upper triple clamp may require the additional purchase of Turn Signal Wiring Kit P/N 72389-96.

I. WINDSHIELD ACORN NUT KIT

Kit contains 10 chrome-plated low crown 12-24 acorn nuts.

94111-95 **\$9.95**
Fits Compact, King-Size, Convertible and Road King® windshields. (Pkg. of 10.)

SEAT OF POWER

The right seat is equal parts ergonomics and comfort. Its shape anchors your position and determines the reach to the ground and to the controls and the padding supports your tailbone and hips to relieve stress and pressure. Pick the right one for you — and your passenger.

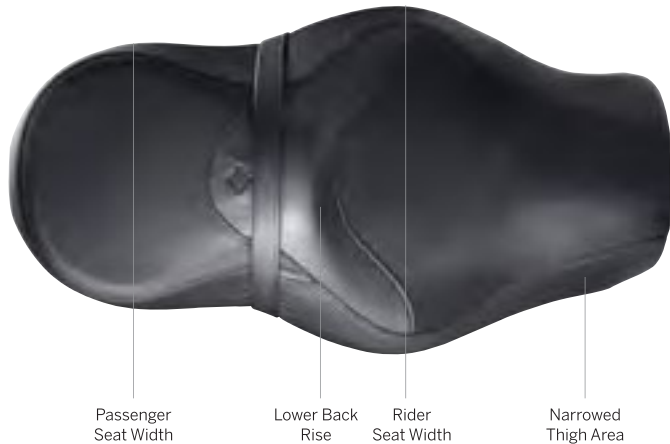
Passenger
Seat WidthLower Back
RiseRider
Seat WidthNarrowed
Thigh Area

PAMPER YOUR BEHIND

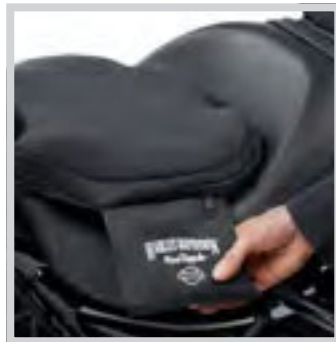

Experience ultimate comfort. Road Zeppelin® seats and seat pads are equipped with a unique air bladder system that distributes rider weight across the entire seating surface. By reducing pressure points and providing shock absorption, this pad allows you to ride your cool low-profile seat for hundreds of miles. The mesh cover lets air circulate beneath the rider's body, reducing the temperature between the rider and seat. The easy-to-reach integrated hand pump and air release valve permits quick and convenient adjustment.

CHANGING YOUR SEAT



Switching out your seat is simple. And because certain rides call for certain styles, some folks like to have multiple seats to match the occasion. Install a comfortable, supportive touring seat for the longer treks and swap it out for a low-profile seat for a night on the town. Please see your owner's manual for proper removal and installation of seats.

SPORTSTER® SEAT TYPES

Solo or two-up, comfort or style, check out these seats to get an idea of where you want to sit.

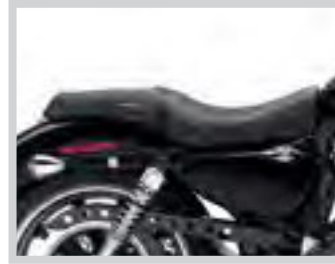

LOW-PROFILE SEATS

These saddles combine radical styling with a "deep-in-the-bike" riding position. Long and lean, Badlander®, Brawler® and Sidekick® seats bring you lower to the ground than most other seats.



REDUCED REACH® SEATS

Get even closer. This Solo Seat is shaped to move the rider 3.0" forward and 1.0" lower for a confident reach to the hand and foot controls. The narrow nose brings the legs 1.0" closer together for a comfortable reach to the ground and the scooped bucket-shape and back support keeps the rider from sliding backward during acceleration.



TOURING SEATS

Designed for comfort, Sundowner™ and Signature Series® seats offer a broad seating surface to reduce pressure points and a dished shape holds you in place and provides additional back support.

CUSTOM SEAT PROGRAM

A personalized seat is the perfect thread to tie your bike's attitude together. Select the stitching pattern, leather inlay and thread color that best support your custom movement and you'll have your personalized seat in just three weeks. For more details, turn to page 796 or visit h-d.com/customseat.



SPORTSTER® 79

Seating – Low Profile



A. BRAWLER SOLO SEAT

A. BRAWLER® SOLO SEAT

When it's time to go it alone, go in style. These premium quality cowhide leather solo saddles feature a smooth, sleek design that hugs the frame rails for a true custom look. Top-grain leather seating surface and contoured foam padding add long-haul comfort and the durable hand-laid fiberglass seat pan is carpeted to protect the paint finish. This seat does not fit with passenger pillions.

52940-04B **\$299.95**

Fits '04-later XL models equipped with 4.5 gallon fuel tank.

Seat width 12.5".

52941-04B **\$299.95**

Fits '04-later XL models equipped with 3.3 gallon fuel tanks.

Seat width 12.5".

52198-03 **\$299.95**

Fits '83-'03 XL models. Seat width 12.5".

B. SIDEKICK® SEAT

Share your custom ride with a passenger. This two-up cowhide leather seat offers a frame-hugging look, but adds back support for the rider and additional padding for the passenger. Top-grain leather seating surface and contoured foam padding add long-haul comfort and the durable hand-laid fiberglass seat pan is carpeted to protect the paint finish.

52849-04B **\$329.95**

Fits '04-later XL models equipped with 4.5 gallon fuel tank.

Models not equipped with passenger pegs require separate purchase of Passenger Footpeg Kit P/N 50203-04 ('04-'13 models) or P/N 50500270 ('14-later models). Seat width 12.5"; passenger pillion width 5.0".

52859-04B **\$329.95**

Fits '04-later XL models equipped with 3.3 gallon fuel tanks.

Models not equipped with passenger pegs require separate purchase of Passenger Footpeg Kit P/N 50203-04 ('04-'13 models) or P/N 50500270 ('14-later models). XL1200N models also require separate purchase of Retention Washer P/N 7487. Seat width 12.5"; passenger pillion width 5.0".



B. SIDEKICK SEAT

Notice: The prices appearing in this catalog are the manufacturer's suggested retail prices. Actual retail prices may vary.

To add custom inlays and stitching to your Brawler® or Sidekick® seat, see pages 796-797, or visit: www.h-d.com/customseat.



80 SPORTSTER®

Seating – Solo

A. BOBBER SOLO SADDLE

How low can you go? This minimalist solo seat takes the stripped-down garage-built look about as far as you can go. The thick distressed black leather cover is bonded directly to the formed metal seat pan and minimizes the foam filler and the extra height it brings. The raw-edge leather features brass rivets and “Milwaukee Since 1903” trim that will develop a rich patina with use and a Bar & Shield logo burned into the surface. Easy to install, the bolt-on seat and model-specific Installation Kit includes everything you need to get the bobber look. No cutting, welding or fabrication is necessary.

52000180 Black Distressed Leather. **\$299.95**
Fits '04-'06 XL, '10-later XL, '06-later Dyna® and '08-later FXS, FLS, FLSTC, FLSTN, FLSTF and FLSTFB models.
Installation requires separate purchase of model-specific Rigid or Spring Saddle Mounting Hardware Kit.

B. SOLO SADDLE

Add nostalgic “bobber” looks to your modern Harley-Davidson® motorcycle. This elegant solo seat features a low-profile design that provides the minimalistic “just enough to ride” look. The smooth metal seat pan and the simple frame cover leave a clean, finished appearance. Easy to install, the bolt-on seat and model-specific Rigid or Spring Seat Installation Kit includes everything you need to get the bobber look. No cutting, welding or fabrication is necessary and the seat can be removed and replaced with a touring seat for a two-up night on the town.

Fits '04-'06 XL, '10-later XL, '06-later Dyna and '08-later FXS, FLS, FLSTC, FLSTN, FLSTF and FLSTFB models. Installation requires separate purchase of model-specific Rigid or Spring Saddle Mounting Hardware Kit.

54373-10	Black Leather.	\$299.95
54072-10	Brown Leather.	\$299.95
52000114	Black Diamond.	\$299.95
52000113	White Diamond.	\$299.95

Also available:

RIGID MOUNT SADDLE INSTALLATION KIT

Get the low lean minimalistic garage built look. Required for installation of Solo Saddle Kits P/N 52000180, 54072-10, 54373-10, 52000114 and 52000113. Kit includes mounting brackets and hardware.

52100016 **\$229.95**
Fits '10-later XL models.

Also available:

SPRING SADDLE INSTALLATION KIT

The torsion-style springs are designed for the optimum balance between spring suspension and support. Required for installation of Solo Spring Saddle Kit P/N 52000180, 54072-10, 54373-10, 52000114 and 52000113. Kit includes springs, mounting brackets, frame cover and hardware.

54074-10 **\$229.95**
Fits '04-'06 and '10-later XL models.

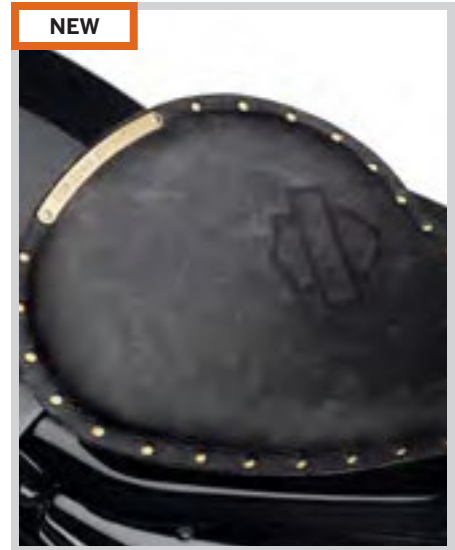

A. BOBBER SOLO SADDLE – BLACK DISTRESSED LEATHER (SHOWN WITH RIGID MOUNT SADDLE INSTALLATION KIT)

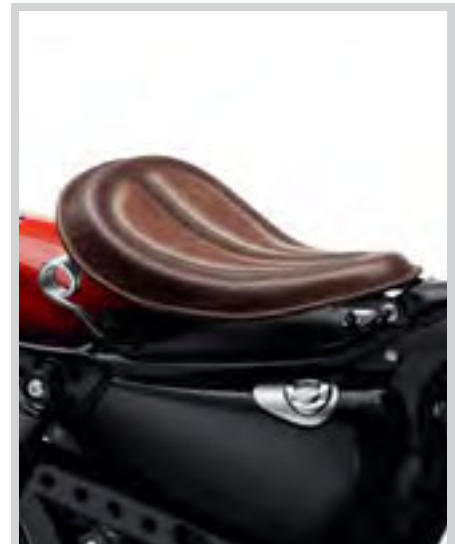

B. SOLO SADDLE – BLACK LEATHER (SHOWN WITH SPRING SADDLE INSTALLATION KIT)

B. SOLO SADDLE – BROWN LEATHER (SHOWN WITH SPRING SADDLE INSTALLATION KIT)

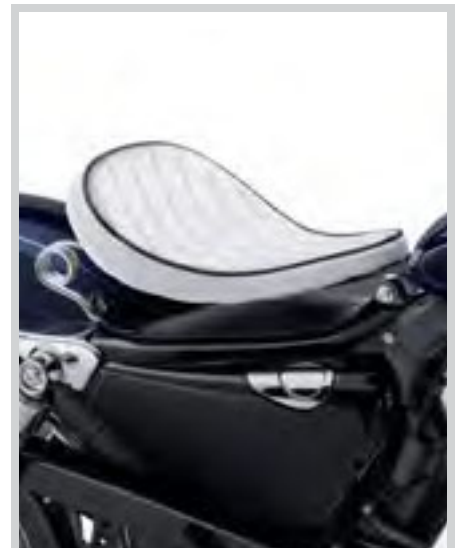

B. SOLO SADDLE – BLACK DIAMOND (SHOWN WITH SPRING SADDLE INSTALLATION KIT)

B. SOLO SADDLE – WHITE DIAMOND (SHOWN WITH SPRING SADDLE INSTALLATION KIT)

Note: Some Harley-Davidson seats are made of leather. Fine leathers or other natural materials WILL gain “character,” such as wrinkles or wear, with age. This is normal. A fine, aged patina and character wrinkles are a sign of the extremely high quality materials used to construct your seat or backrest. The appearance of scars or marks on the leather are a result of using natural leather panels and should not be thought of as an imperfection. Please use Harley-Davidson Leather Protectant P/N 93600034 to protect your investment.

Notice: The prices appearing in this catalog are the manufacturer's suggested retail prices. Actual retail prices may vary.



C. METAL FLAKE SOLO SEAT – SILVER CHARCOAL

C. METAL FLAKE SOLO SEAT – SILVER CHARCOAL

Add a little sparkle to your ride with this custom Metal Flake Solo Seat. With a nod to the choppers and bobbers of the '60s and '70s, this minimalistic seat features a brilliant high-gloss metal flake vinyl seating surface that is finished in the classic diamond checked upholstery pattern. The look will stop traffic and will certainly make your ride stand out in a crowd.

52000051 **\$149.95**

Fits '10-later XL models with 2.2 or 3.3 gallon fuel tank. Seat width 10.0".

D. SIGNATURE SERIES® SOLO SEAT WITH RIDER BACKREST

A perfect combination of foam density and shape has created our most comfortable seat for long-haul touring. The wide-seating area will keep the rider extra comfy on a long trip and when you reach your destination, city driving will be easier with the narrow nose that helps keep your legs closer together. Seat features an easily removable adjustable rider backrest that folds down for easier passenger mounting. Rider backrest has a 5-position height adjustment with 1.5" range and a wide range of forward/back angle adjustment with a quick twist of the control knob. Matching Passenger Pillion is available for added versatility.

52000034 **\$499.95**

Fits '07-later XL models with 4.5 gallon fuel tank. Seat width 15.0".

52000062 **\$499.95**

Fits '07-later XL models with 2.2 or 3.3 gallon fuel tank. Seat width 15.0".



D. SIGNATURE SERIES SOLO SEAT WITH RIDER BACKREST

E. QUICK-RELEASE RIDER BACKREST

Add exceptional comfort for open road and around town riding. This detachable rider backrest is shaped for maximum lower back support and keeps you in place without shifting you forward in the saddle. Designed to complement Original Equipment and accessory solo seats, the backrest's forward/back position can be adjusted up to 4.5" with a simple fingertip adjustment. The fold-down pad clears the way when throwing your leg over the bike and the backrest can be removed from the bike with the push of a button—leaving behind just two elegant docking points. Complete kit includes upright, pad, fender strut brackets and all required hardware.

52300245 **\$249.95**

Fits '04-later XL models equipped with a solo seat. Not for use with Brawler® Solo Seat P/N 52940-04B, 52941-04B, 52000118, 52000119, Solo Rigid or Spring Seat Mounting Kits or Side-Mount License Plate Kit P/N 60947-10 or 60972-10. Installation of H-D® Detachables™ Solo Luggage Rack requires additional purchase of Bolt P/N 3584 (Qty. 4).

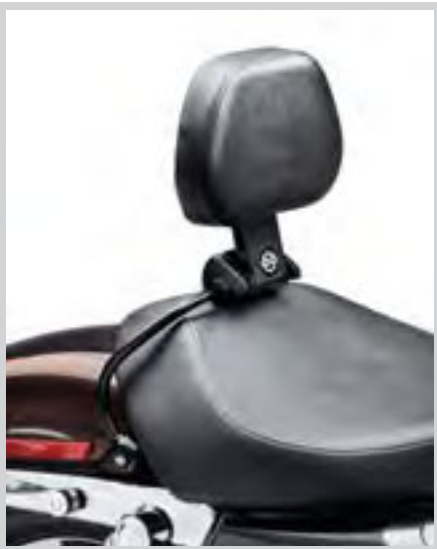

E. QUICK-RELEASE RIDER BACKREST

Note: Some Harley-Davidson seats are made of leather. Fine leathers or other natural materials WILL gain "character," such as wrinkles or wear, with age. This is normal. A fine, aged patina and character wrinkles are a sign of the extremely high quality materials used to construct your seat or backrest. The appearance of scars or marks on the leather are a result of using natural leather panels and should not be thought of as an imperfection. Please use Harley-Davidson Leather Protectant P/N 93600034 to protect your investment.

Notice: The prices appearing in this catalog are the manufacturer's suggested retail prices. Actual retail prices may vary.

82 SPORTSTER®

Seating – Pillion

A. SIGNATURE SERIES® PASSENGER PILLION

Bring someone along for the ride without giving up your solo status. This carefully styled pillion matches the Sportster® Signature Series® Solo Seat and provides your passenger with a wide seating surface for hours of comfort.

52400053 \$149.95

Fits '07-later XL models equipped with Signature Series Solo Seat P/N 52000034 or 52000062. Pillion width 10.0".

B. PASSENGER PILLION

Low-profile, minimalistic Passenger Pillion features grey stitching to complement the Original Equipment solo seat on XL1200V and XL1200X models. Easy to install with included hardware and grab strap.

51734-10 \$129.95

Fits XL1200V and XL1200X models equipped with Original Equipment solo seat. Requires installation of passenger footpegs (sold separately). Pillion width 7.75".

C. PASSENGER PILLION

Bring a guest along on your solo-seat equipped Sportster model. The smooth cover and top stitching of this Passenger Pillion complements the Original Equipment solo seat and the Reduced Reach® Solo Seat. Kit includes grab strap and mounting hardware.

51744-07A \$114.95

Fits '07-later XL models (except XL1200V and XL1200X) equipped with Original Equipment or Reduced Reach® Solo Seats. Requires installation of passenger footpegs (sold separately). XL883N and XL1200N models also require separate purchase of Retention Washer P/N 7487. Pillion width 10.0".

51546-04 \$119.95

Fits '04-'06 XL883 models. Requires installation of passenger footpegs (sold separately). Pillion width 9.5".

D. REAR FENDER BIB

Go solo in style. Form-fitted to hug the contour of the rear fender, this decorative fender cover hides the seat mounting holes that are exposed when riding with a solo seat. Wrapped in smooth vinyl to match Original Equipment or accessory solo seats, the Fender Bib features an embossed Bar & Shield logo for added style. The molded base is finished with a soft felt under-liner designed to protect the fender's painted surface.

52017-08 \$59.95

Fits '04-later XL models (except XL1200T, XL1200V and XL1200X) equipped with Original Equipment solo seat or Reduced Reach Solo Seat P/N 51750-07 or 51751-07. Will not fit models equipped with Bobtail Rear Fender.

E. BADLANDER® SEAT

A perfect seating surface for cruising the town, this low, slammed seat offers a clean, custom look. The smooth covers and subtle top-stitching feature two embroidered "Harley-Davidson" logos.

51749-07 \$249.95

Fits '07-later XL models equipped with 4.5 gallon fuel tank. Models not equipped with passenger pegs require separate purchase of Passenger Footpeg Kit P/N 50203-04 ('04-'13 models) or P/N 50500270 ('14-later models). Seat width 12.0"; passenger pillion width 5.0".

51747-07 \$249.95

Fits '07-later XL models equipped with 2.2 or 3.3 gallon fuel tanks. Models not equipped with passenger pegs require separate purchase of Passenger Footpeg Kit P/N 50203-04 ('04-'13 models) or P/N 50500270 ('14-later models). XL883N, XL1200N and XL1200X models also require separate purchase of Retention Washer P/N 7487. Seat width 12.0"; Passenger pillion width 5.0".

52296-94B \$249.95

Fits '83-'03 XL models. Seat width 12.0"; passenger pillion width 5.0".



A. SIGNATURE SERIES PASSENGER PILLION



B. PASSENGER PILLION



C. PASSENGER PILLION –
(‘04-‘06 XL883 MODELS SHOWN)

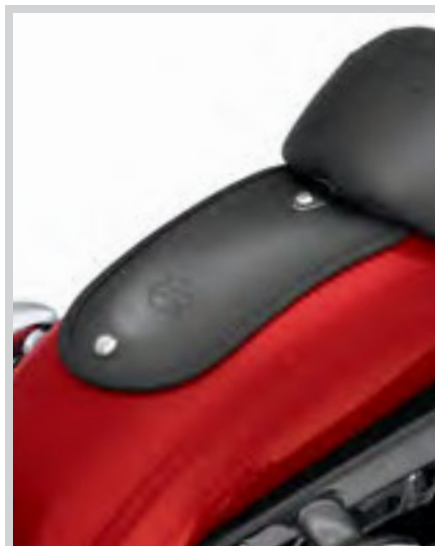

D. REAR FENDER BIB



E. BADLANDER SEAT



F. SUPER REDUCED REACH SOLO SEAT

F. SUPER REDUCED REACH® SOLO SEAT

Get a little bit closer. Super Reduced Reach® forward position seats are designed to move riders with a shorter inseam even closer to the controls and to bring the legs about 1.0" closer together so that your feet rest firmly on the pavement. The scooped bucket-shaped saddle is enhanced with added back support padding to move the rider up to 1.0" lower and 3.0" forward. The combination positions the rider closer to the hand and foot controls to offer both comfort and confidence. For a two-up ride, combine the solo seat with the Touring Passenger Pillion P/N 51744-07A (sold separately).

54385-11 **\$229.95**

Fits '07-later XL models equipped with 4.5 gallon fuel tank. Seat width 10.5".

54386-11 **\$229.95**

Fits '07-later XL models equipped with 2.2 or 3.3 gallon fuel tanks. XL883N, XL1200N and XL1200X models also require separate purchase of Retention Washer P/N 7487. Seat width 10.5".

G. REDUCED REACH SOLO SEAT

Need to get your feet firmly on the ground? This ergonomically friendly Solo Seat moves the rider .5" forward and offers a truly comfortable seating option for the rider with a shorter inseam. The wide bucket surface provides a comfortable perch for those long rides, while the narrow front brings your legs together for a more natural riding position around town.

51751-07 **\$229.95**

Fits '07-later XL models equipped with 4.5 gallon fuel tank.

51750-07 **\$229.95**

Fits '07-later XL models equipped with 2.2 or 3.3 gallon fuel tanks. XL883N, XL1200N and XL1200X models also require separate purchase of Retention Washer P/N 7487.

H. LOW-PROFILE SOLO SEAT

This Low-Profile Solo Seat offers a truly comfortable seating option for the rider with a shorter inseam. The wide bucket surface provides a comfortable perch for those long rides, while the narrow front brings your legs together for a more natural riding position around town.

51538-04 **\$199.95**

Fits '04-'06 XL models equipped with 4.5 gallon fuel tank. Seat width 14.5".

51538-00 **\$199.95**

Fits '83-'03 Sportster® models. Seat width 14.5".

I. REDUCED REACH SEAT

Designed specifically for riders requiring a close to the bar riding position, without compromising comfort. This seat positions the rider approximately .5" forward, closer to the hand and foot controls. The narrow front profile brings your legs closer together to help you plant your feet firmly on the ground. The slightly bucketed rider seat offers lower back support and features a textured insert to prevent you from sliding around while riding.

51738-07 **\$304.95**

Fits '07-later XL models equipped with 4.5 gallon fuel tank.

Models not equipped with passenger pegs require separate purchase of Passenger Footpeg Kit P/N 50203-04 ('04-'13 models) or P/N 50500270 ('14-later models). Seat width 14.0"; passenger pillion width 10.0".

51737-07 **\$304.95**

Fits '07-later XL models equipped with 2.2 or 3.3 gallon fuel tanks. Models not equipped with passenger pegs require separate purchase of Passenger Footpeg Kit P/N 50203-04 ('04-'13 models) or P/N 50500270 ('14-later models). XL883N, XL1200N and XL1200X models also require separate purchase of Retention Washer P/N 7487. Seat width 14.0"; passenger pillion width 10.0".

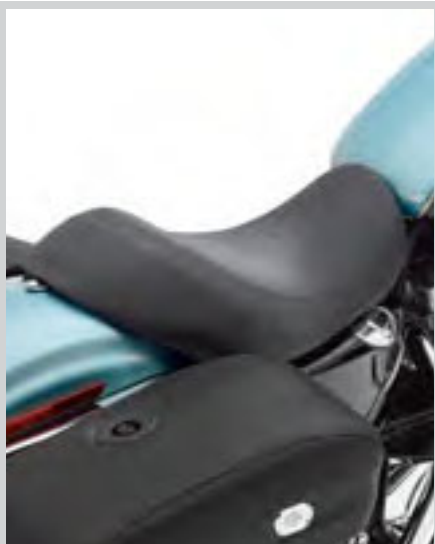

G. REDUCED REACH SOLO SEAT



H. LOW-PROFILE SOLO SEAT



I. REDUCED REACH SEAT

84 SPORTSTER®

Seating – Two Up

A. RALLYRUNNER® SEAT

The two-up profile of this custom seat maintains a lean look, but adds back support for the rider and additional padding for the passenger. Made of the highest quality cowhide, this premium seat offers a radical style with a touch of comfort. Top-grain leather seating surface and contoured foam padding add long-haul comfort and the durable hand-laid fiberglass seat pan is carpeted to protect the paint finish.

52916-04B **\$329.95**

Fits '04-later XL models equipped with 4.5 gallon fuel tank. Models not equipped with passenger pegs require separate purchase of Passenger Footpeg Kit P/N 50203-04 ('04-'13 models) or P/N 50500270 ('14-later models). Seat width 12.5"; passenger pillion width 8.0".

52923-04B **\$329.95**

Fits '04-later XL models equipped with 3.3 gallon fuel tanks. Models not equipped with passenger pegs require separate purchase of Passenger Footpeg Kit P/N 50203-04 ('04-'13 models) or P/N 50500270 ('14-later models). XL1200N models also require separate purchase of Retention Washer P/N 7487. Seat width 12.5"; passenger pillion width 8.0".

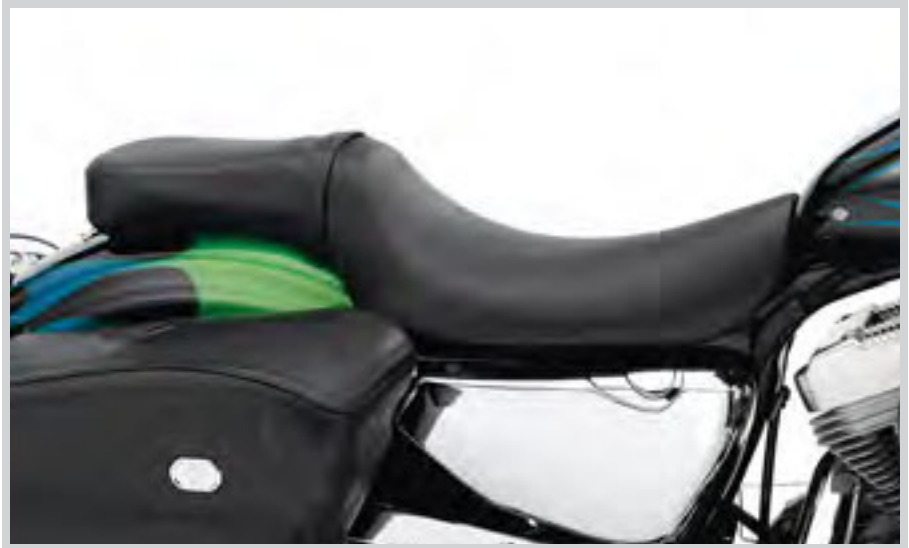

A. RALLYRUNNER SEAT

B. ROAD ZEPPELIN® AIR ADJUSTABLE SEAT

The mating of comfort and style. Low-profile Road Zeppelin® Seats are equipped with a unique adjustable air bladder system that distributes your weight across the seating surface. The air bladder system removes pressure points and provides shock absorption for the rider's and passenger's tailbone. You get hours of riding comfort, without sacrificing the low-slung custom look. The combination of smooth vinyl and waterproof textured fabric seating surfaces allows air to circulate beneath the body, reducing the air temperature between the rider and seat. The easy-to-reach integrated hand pumps and air release valves permit quick and convenient adjustment for both the rider and passenger.

52000145 **\$549.95**

Fits '04-later XL models. Models not equipped with passenger pegs require separate purchase of Passenger Footpeg Kit P/N 50203-04 ('04-'13 models) or P/N 50500270 ('14-later models). Seat width 12.0"; passenger pillion width 10.5".



B. ROAD ZEPPELIN AIR ADJUSTABLE SEAT

C. SUNDOWNER™ SEAT

The Sundowner™ Seat provides the maximum in long-riding comfort. The deep-bucket design puts your body in the proper touring position and the generous padding makes it comfortable for both the rider and passenger as the miles are adding up. The dish-shaped back provides added rider back support and the wide passenger pillion is shaped to minimize pressure points.

51739-07 **\$319.95**

Fits '07-later XL models equipped with 4.5 gallon fuel tank. Models not equipped with passenger pegs require separate purchase of Passenger Footpeg Kit P/N 50203-04 ('04-'13 models) or P/N 50500270 ('14-later models). Seat width 14.5"; passenger pillion width 12.0".

51736-07 **\$319.95**

Fits '07-later XL models equipped with 2.2 or 3.3 gallon fuel tanks. Models not equipped with passenger pegs require separate purchase of Passenger Footpeg Kit P/N 50203-04 ('04-'13 models) or P/N 50500270 ('14-later models). XL883N, XL1200N and XL1200X models also require separate purchase of Retention Washer P/N 7487. Seat width 14.5"; passenger pillion width 12.0".

51507-04 **\$319.95**

Fits '04-'06 XL models equipped with 4.5 gallon fuel tank. Models not equipped with passenger footpegs require separate purchase of Passenger Footpeg Kit P/N 50203-04 ('04-'13 models) or P/N 50500270 ('14-later models). Seat width 15.0"; passenger pillion width 12.5".

51509-04 **\$319.95**

Fits '04-'06 XL models equipped with 3.3 gallon fuel tank. Models not equipped with passenger footpegs require separate purchase of Passenger Footpeg Kit P/N 50203-04 ('04-'13 models) or P/N 50500270 ('14-later models). Seat width 15.0"; passenger pillion width 12.5".

51544-01A **\$319.95**

Fits '83-'03 XL models. Seat width 15.0"; passenger pillion width 12.5".

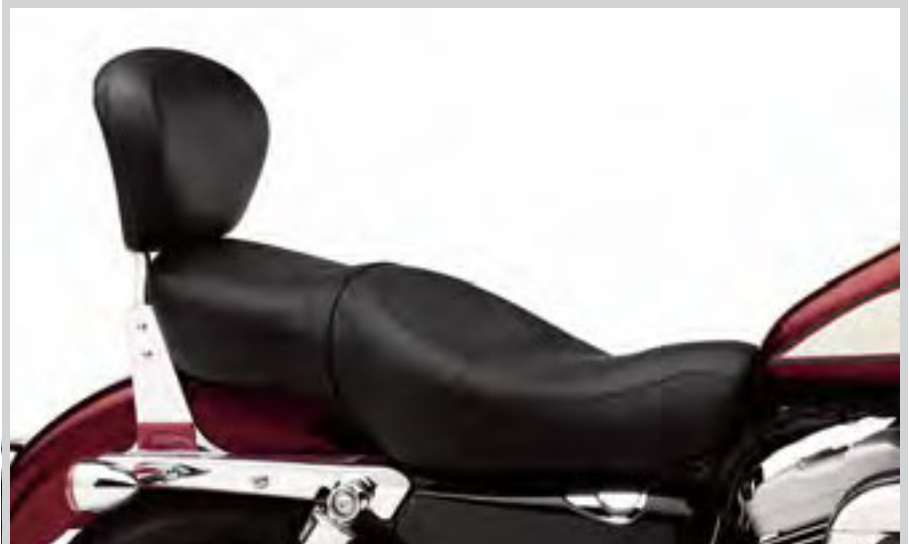

C. SUNDOWNER SEAT (SHOWN WITH SMOOTH BUCKET LOW BACKREST PAD)

Notice: The prices appearing in this catalog are the manufacturer's suggested retail prices. Actual retail prices may vary.



D. CIRCULATOR SEAT PAD

D. CIRCULATOR SEAT PADS

Keep comfortable on your next long ride. These breathable Circulator Seat Pads feature 3D construction that promotes air movement and reduces heat build-up where the rider's body touches the seat or backrest. Designed to keep the rider cool by reducing the perspiration build-up between you and the seating surface, the Circulator Pad can be installed and removed in seconds for easy cleaning. The low-profile design minimizes seat-height change compared to inflatable pads, while enhancing comfort with its shock-absorbing construction. Manufactured of UV-stable materials, these seat pads resist fading when exposed to the sun. Elastic under-seat strap and non-slip base provide secure installation and the available Circulator Passenger Pillion Pad attaches to the rider pad with hook-and-loop tabs.

51074-10 Medium Seat Pad. **\$79.95**
Fits VRSC™, XG, XL and Dyna® models with Original Equipment and accessory seats. Pad width – 14.5"

51078-10 Passenger Pillion Pad. **\$69.95**
Fits Original Equipment and accessory passenger pillions. Pad width – 13.0"

E. ROAD ZEPPELIN® SEAT PAD

Experience ultimate comfort. Road Zeppelin® Seat Pads are equipped with a unique air bladder system that allows your weight to be distributed evenly across the entire seating surface, ensuring hours of comfort for both rider and passenger. The air bladder system is designed to remove pressure points and provide shock absorption to reduce vibration. The mesh cover allows air to circulate beneath the rider's body, reducing the air temperature between the rider and seat. The easy-to-reach integrated hand pump and air release valve permits quick and convenient adjustment. Shaped to conform to most Harley-Davidson® seats, the pads feature an adjustable mounting strap and a non-skid surface to keep them in place.

52000084 Rider. **\$129.95**
Fits rider position on all models equipped with Original Equipment or accessory seats. Also fits passenger position on Touring models with large pillion area. Pad width – 14.0".

52400060 Passenger Pillion. **\$129.95**
Fits Original Equipment and accessory passenger pillions. Pad length – 11.0"; width – 8.0".

F. QUICK-RELEASE SEAT HARDWARE KIT

These hardware kits allow the rider to remove one-piece Harley-Davidson seats quickly and easily.

51676-97A **\$19.95**
Fits '97-later XG, XL, Dyna, Softail® (except FLS models equipped with Original Equipment seat), Touring and Trike models. Does not fit seats equipped with spring-loaded rear seat bracket.



E. ROAD ZEPPELIN SEAT PAD



E. ROAD ZEPPELIN SEAT PAD



F. QUICK-RELEASE SEAT HARDWARE KIT

Notice: The prices appearing in this catalog are the manufacturer's suggested retail prices. Actual retail prices may vary.

86 SPORTSTER®

Backrests & Racks

Choosing a Backrest

A sissy bar upright and passenger backrest are the starting point to build a complete touring machine. The backrest provides long-range comfort and support and adds a feeling of control and confidence for the passenger. For permanent installation, choose rigid sideplates and a style of upright that suits your riding style. For added flexibility, choose a H-D® Detachables™ Sideplate Kit and appropriate Docking Hardware to make adding or removing a detachable accessory a simple “slide and click” proposition.



H-D Rigid Sideplates

Add practical comfort and support for your passenger. Rigid Sideplates support are the anchor for sissy bar uprights, backrest pads and luggage racks and hug the rear fender strut for a clean streamlined look. Manufactured and tested to rigorous Harley-Davidson® standards, these sideplates are designed to specific model application for exact fit.

Fits '04-later XL models (except XL1200T). Does not fit models equipped with saree guards.

1. 53925-04 Chrome. **\$99.95**

Fits '94-'03 XL models.

2. 52806-94B Chrome. **\$99.95**



1

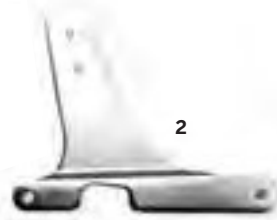

2



H-D® Detachables™ Sideplates

In the time it takes for a traffic light to change, you can transform your motorcycle from a city cruiser to a cross country hauler. Start with Harley-Davidson® Detachables Sideplates, and add your choice of sissy bar upright and pad to make removing the passenger backrest a simple “slide and click” operation. Manufactured and tested to rigorous Harley-Davidson® standards, installation requires separate purchase of model-specific Docking Hardware Kit.

Fits '04-later XL models. All models (except XL1200T) require separate purchase of Docking Hardware Kit (see docking hardware matrix).

3. 53913-04 Chrome. **\$144.95**

4. 52710-07 Gloss Black. **\$144.95**

Fits '94-'03 XL models. Requires separate purchase of Docking Hardware Kit (see docking hardware matrix).

53545-95 Chrome. **\$144.95**



3



4



H-D Adjustable Sideplates

Enhance your passenger's ride with an adjustable passenger backrest. When combined with your choice of Sissy Bar Upright and Backrest Pad, these Premium Adjustable Sideplates allow the passenger to change the recline angle of the passenger backrest for maximum comfort. Simply pull on the release levers and adjust the upright to one of three different recline settings. The exclusive cam lock detachable design lets you add or remove the passenger backrest assembly in seconds.

Fits '04-later XL models. All models (except XL1200T) require separate purchase of Docking Hardware Kit.

52300116 Chrome. **\$229.95**

52300096 Gloss Black. **\$229.95**



Notice: The prices appearing in this catalog are the manufacturer's suggested retail prices. Actual retail prices may vary.

Select a Height



Tall

Tall Sissy Bar Upright

Let your passenger ride tall in the saddle with a Tall Sissy Bar Upright. This upright provides maximum upper back support when equipped with your choice of Backrest Pad.



Standard

Standard Sissy Bar Upright

Give your passenger additional back support with a Standard Sissy Bar Upright, designed to accept a wide variety of Backrest Pads.



Low

Low Sissy Bar Upright

Shaped to complement a thicker passenger pillion, this Low Sissy Bar Upright stands between the Standard and Short Sissy Bar Upright. The ideal match for touring style seats, this upright also offers an additional height option to riders with custom style seats.



Short

Short Sissy Bar Upright

This Short Sissy Bar Upright is lower than traditional low uprights and the hidden Backrest Pad Mounting System allows for a sleek look when the pad is removed.

Select a Style



**Square Bar
Medallion Style with
3-Bolt Pad Mount**



**Round Bar
Mini Medallion Style
with 3-Bolt Pad Mount**



**Round Bar
Mini Medallion Style
with 2-Bolt Pad Mount**

Sissy Bar Uprights are available in a variety of shapes and styles. Square bar uprights feature a traditional plate design that provides a flat surface that is ideal for displaying self-adhesive medallions. Round bar uprights feature a mini medallion bar and an embossed Bar & Shield insert. Uprights are designed to accept specific 3-bolt or 2-bolt mounted backrest pads.

Select Your Model

Height	Bar Style	Style	Finish	Fits '82-'03 XL models		Fits '04-later XL models with Rigid Sideplates		Fits '04-later XL models with H-D® Detachables™ Sideplates	
Short	Square	Insert	Chrome	—	—	51513-02	\$74.95	52737-94A	\$74.95
Short	Square	Insert	Gloss Black	—	—	—	—	52706-07	\$74.95
Low	Round	Mini Medallion	Chrome	—	—	—	—	52300022	\$99.95
Low	Round	Mini Medallion	Gloss Black	—	—	—	—	52300024	\$99.95
Low	Square	Medallion	Chrome	52655-84	\$89.95	52909-02	\$89.95	52754-04	\$99.95
Low	Square	Medallion	Gloss Black	—	—	—	—	51851-09	\$99.95
Standard	Round	Mini Medallion	Chrome	—	—	—	—	52300018	\$99.95
Standard	Round	Mini Medallion	Gloss Black	—	—	—	—	52300020	\$99.95
Standard	Square	Medallion	Chrome	—	—	—	—	52735-85	\$89.95
Tall	Square	Medallion	Chrome	52777-85A	\$99.95	—	—	—	—

88 SPORTSTER®

Backrests & Racks



Typical H-D® Detachables™ Docking Hardware Kit

Select the Docking Hardware

Sportster Docking Hardware for H-D® Detachables™ Racks and Sideplates

Docking hardware fitment is dependent on vehicle model and saddlebag configuration.

<i>H-D Detachables Accessory</i>	<i>Available to fit:</i>	Required Docking Hardware	
Detachable Sideplates, Detachable Solo Rack 53494-04, 53512-07 One-Piece Detach Sissy Bar Upright 51146-10, 52300040 or Detachable Solo Tour-Pak® Rack 53655-04 with Leather Saddlebags 90330-08.	2004-later XL models (except XL883N, XL1200N, XL1200V and XL1200X)	53544-04	\$44.95
Detachable Sideplates, Detachable Solo Rack 53494-04, 53512-07 One-Piece Detach Sissy Bar Upright 51146-10, 52300040 or Detachable Solo Tour-Pak Rack 53655-04 with Leather Saddlebags 53050-10 and 88312-07A.	2004-later XL models	53544-04	\$44.95
Detachable Sideplates, Detachable Solo Rack 53494-04, 53512-07 One-Piece Detach Sissy Bar Upright 51146-10 without Leather Saddlebags.	2004-later XL models	53529-04	\$44.95
Detachable Sideplates or Detachable Solo Rack 53494-04, 53512-07 One-Piece Detach Sissy Bar Upright 51146-10 or Solo Tour-Pak Mounting Rack 53655-04 with Hard Saddlebags 91412-0XXX. Hard Saddlebags also require purchase of Hardware Kit 91405-04.	2004-later XL models (except XL883N, XL1200N, XL1200V and XL1200X)	53529-04	\$44.95
Detachable Sideplates 53545-95, 53609-01 or Detachable Solo Rack 53495-95 with Leather Saddlebags 90598-04, 90342-04A or 90330-08.	1994-2001 XL models	90465-98A	\$69.95
	2002-2003 XL (except XL Sport)	53532-02	\$69.95
Detachable Sideplates 53545-95, 53609-01 or Detachable Solo Rack 53495-95 without Leather Saddlebags.	1994-2003 XL models	53528-95B	\$44.95

A. ONE-PIECE H-D® DETACHABLES™ Sissy BAR UPRIGHT

The sweeping shape of this slim, round bar Sissy Bar Upright completes the classic "bobber" look. The one-piece design eliminates separate sideplates for a clean appearance and the stylized upper kick angle mimics the old-school sissy bars of the '50s and '60s. Available in your choice of chrome or gloss black finish, these bars can be equipped with Passenger Backrest Pad P/N 52631-07.

Fits '04-later XL models. All models (except XL1200T) require separate purchase of appropriate Docking Hardware Kit.

51146-10	Gloss Black.	\$199.95
52300040	Chrome.	\$209.95

Shown with:

PASSENGER BACKREST PAD

Styled to complement available touring and custom seats.

Fits models equipped with One Piece H-D® Detachables™ Sissy Bar Upright P/N 52729-08, 51853-07, 51849-07, 51146-10, 51161-10, 52300040, 52300042, 52300044 or 52300046.

52631-07	Smooth Black.	\$69.95
-----------------	---------------	----------------



A. ONE-PIECE H-D DETACHABLES Sissy BAR UPRIGHT – GLOSS BLACK (SHOWN WITH PASSENGER BACKREST PAD)



A. ONE-PIECE H-D DETACHABLES Sissy BAR UPRIGHT – CHROME (SHOWN WITH PASSENGER BACKREST PAD)

Notice: The prices appearing in this catalog are the manufacturer's suggested retail prices. Actual retail prices may vary.

**B. LOCKING H-D DETACHABLES LATCH KIT – CHROME****B. LOCKING H-D® DETACHABLES™ LATCH KIT**

This unique lock replaces the camlock on your Harley-Davidson® Detachables™ accessories, providing additional security and peace of mind when parking your vehicle. The kit includes two extended-reach barrel-style keys for easy access to the lock. Key registration and replacement service is available. Sold in pairs.

Fits all models equipped with detachable Sideplates, Racks and Tour-Pak® Luggage Carriers (except '09-later Touring models equipped with detachable Solo Tour-Pak Rack).

90300087 Chrome. **\$79.95**

90300086 Black. **\$69.95**

C. H-D DETACHABLES LATCH KIT – CHROME

Decorative chrome latches are the perfect way to enhance the appearance of your detachable accessories. Meticulously polished and chrome-plated, these easy-to-install Rotary Latches are a direct replacement for the Original Equipment satin black parts and are a simple way to add a finishing touch to your ride. Latches feature an easy-to-pull finger release to simplify access in hard-to-reach areas.

12600036 **\$49.95**

Fits all models equipped with detachable Sideplates, One-Piece Sissy Bar Uprights, Racks and Tour-Pak Luggage Mounting Racks.

**B. LOCKING H-D DETACHABLES LATCH KIT – BLACK****C. H-D DETACHABLES LATCH KIT – CHROME****D. REAR DOCKING HARDWARE COVER KIT**

Disguise the rear docking hardware with these easy-to-install covers. The caps slide over the exposed docking points and are held in place by a strong magnetic pull. The caps are easy to remove when you wish to reinstall detachable accessories. Covers are available with brilliant chrome or durable gloss black finish to match your bike's attitude. Sold in pairs.

Fits many accessory docking hardware kits. Refer to the fitment matrix in this P&A Catalog page 573 or the Parts & Accessories section of www.harley-davidson.com for details.

48218-10 Short Chrome (pair). **\$34.95**

48220-10 Large Chrome (pair). **\$34.95**

48035-09 Small Chrome (pair). **\$34.95**

48221-10 Short Black (pair). **\$34.95**

48223-10 Large Black (pair). **\$34.95**

48225-10 Small Black (pair). **\$34.95**

**D. REAR DOCKING HARDWARE COVER KIT – BLACK****D. REAR DOCKING HARDWARE COVER KIT – CHROME**

Notice: The prices appearing in this catalog are the manufacturer's suggested retail prices. Actual retail prices may vary.

90 SPORTSTER®

Backrests & Racks

PASSENGER BACKREST PADS

Choose from a wide variety of backrest pad sizes and shapes to match your comfort and style demands. Designed to complement Original Equipment and accessory seats, these pads are engineered to fit specific sissy bar upright types.

A. SHORT BACKREST PAD

Innovative Backrest Pad mounting system features a brushed stainless steel insert framed with chrome plate and hardware.

52517-94 **\$59.95**

Fits Short Insert Style Sissy Bar Upright P/N 51513-02, 52737-94A or 52706-07.



A. SHORT BACKREST PAD

B. BACKREST PADS

Sized to fit medallion and mini medallion-style sissy bar uprights. Pad mounts with single center screw and bolt-on mounting strap. Includes chrome-plated mounting hardware.

Fits Low Medallion Style Sissy Bar Upright P/N 52754-04 or 51851-09, Low Square Bar Mini-Medallion Style Sissy Bar Upright P/N 53282-06, Standard Square Bar Mini Medallion Style Sissy Bar Upright P/N 53281-06 or 53407-06, Standard Medallion Style Sissy Bar Upright P/N 52735-85, 53007-98, 52655-84, 52909-02 or 51517-02, Standard Bar & Shield Style Sissy Bar Upright 52739-83 or 51514-02, Standard Heritage Style Sissy Bar Upright P/N 52731-00 and Low Round Bar Sissy Bar Upright P/N 52300022 or 52300024.

1. 52652-04 Smooth. **\$69.95**

2. 52626-04 Smooth Top-Stitched. **\$69.95**



B. BACKREST PADS

C. BACKREST PADS

Sized to fit round bar sissy bar uprights, these pads mount to mini medallion-style uprights with two mounting holes.

Fits Standard Round Bar Mini-Medallion Style Upright P/N 52877-10 or 51168-10. Also fits Low Round Bar Mini Medallion Style Sissy Bar Upright P/N 52540-09A, 51477-06, 54256-10, 52300049 and 52300050.

1. 51641-06 Smooth Top-Stitched. **\$69.95**

2. 51640-06 Smooth Bucket. **\$99.95**

3. 51622-07 Fat Boy® Lacing Bucket. **\$119.95**

4. 52300301 CVO™ FXSBSE Style – Black. **\$129.95**

5. 52300293 CVO FXSBSE Style – Brown. **\$129.95**

6. 52300336 '14 CVO FXSBSE Style. **\$129.95**

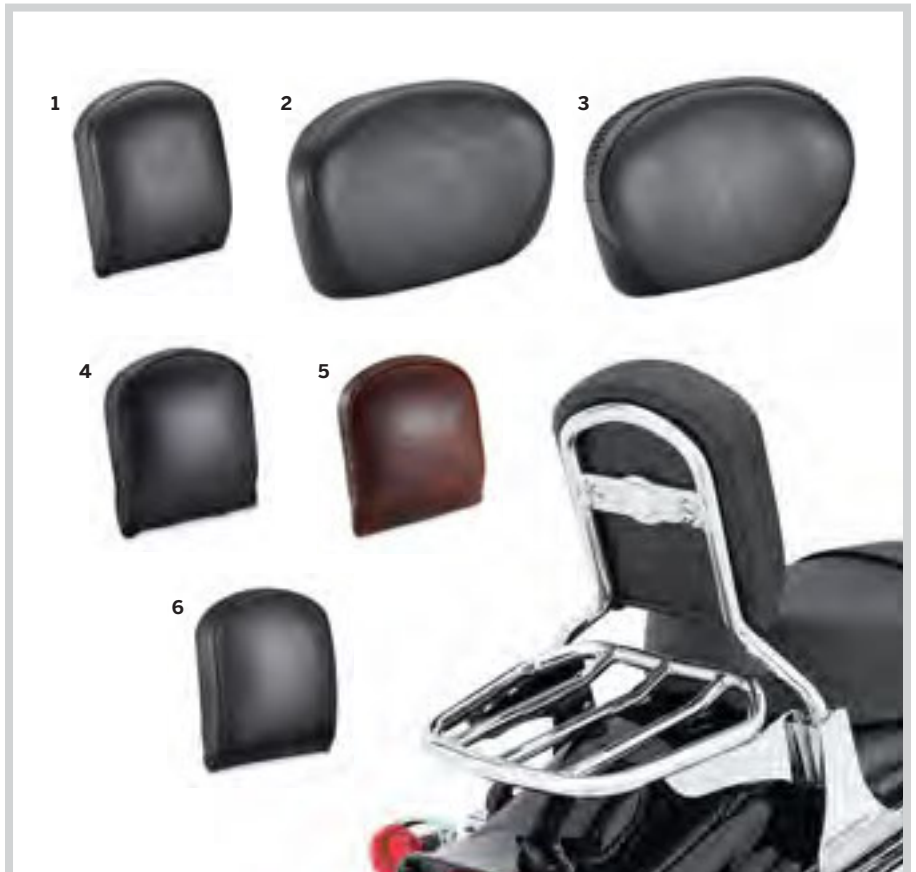

C. BACKREST PADS

Notice: The prices appearing in this catalog are the manufacturer's suggested retail prices. Actual retail prices may vary.



D. BACKREST PADS



E. BACKREST PADS

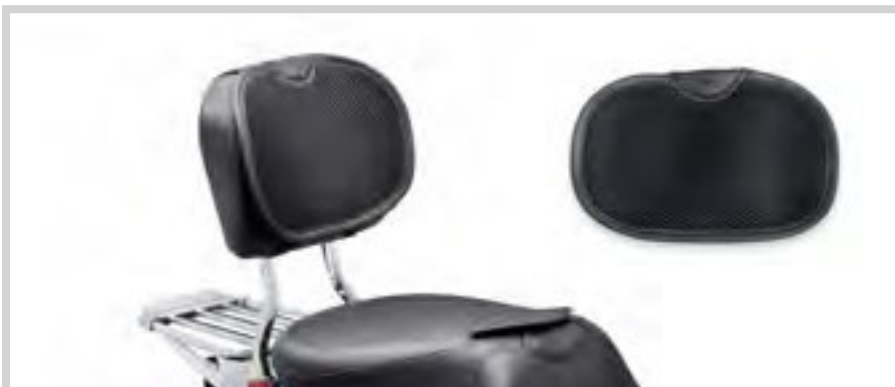

F. CIRCULATOR BACKREST PAD

D. BACKREST PADS

Sized to fit medallion and mini medallion-style sissy bar uprights. Pad mounts with single center screw and bolt-on mounting strap. Kit includes chrome-plated mounting hardware.

Fits Low Medallion Style Sissy Bar Upright P/N 52655-84, 52909-02, 52754-04, 51851-09, Standard Medallion Style Sissy Bar Upright P/N 52735-85 or 52877-08, Standard Square Bar Mini Medallion Style Sissy Bar Upright P/N 53281-06 or 53407-06, Standard Heritage Style Sissy Bar Upright P/N 52731-00 and Standard Round Bar Sissy Bar Upright P/N 52300018 or 52300020.

1. 52612-95	Smooth Top-Stitched.	\$69.95
2. 52412-79A	Embossed Bar & Shield Logo.	\$69.95
3. 52532-90	Fat Boy.®	\$79.95
4. 52348-97	Heritage Classic Bucket.	\$109.95
5. 52347-97	Fat Boy Bucket.	\$99.95
6. 51132-98	Smooth Bucket.	\$99.95

E. BACKREST PADS

Sized to fit tall medallion and insert-style sissy bar uprights. Pads mount with upper bolt-on mounting strap and two lower mounting clips. Kit includes chrome-plated mounting brackets and hardware.

Fits Tall Medallion Style Sissy Bar Upright P/N 52777-85A, 51519-02 or 52749-85A. Also fits Tall Insert Style Sissy Bar Upright P/N 51518-02 or 53552-81A.

52965-98	Smooth Top-Stitched.	\$79.95
-----------------	----------------------	----------------

F. CIRCULATOR BACKREST PAD

Keep comfortable on your next long ride. These breathable Circulator Pads feature 3-D construction that promotes air movement and reduces heat build-up where the rider's body touches the backrest. Designed to keep the rider cool by reducing the perspiration build-up between you and the seating surface, the Circulator Pad can be installed and removed in seconds for easy cleaning. Manufactured of UV-stable materials, these seat pads resist fading when exposed to the sun.

52300103	Wide Backrest Pad.	\$59.95
-----------------	--------------------	----------------

Fits wide profile rider and passenger backrest pads up to 12.0" wide and 9.0" tall.

92 SPORTSTER®

Backrests & Racks

A. AIR FOIL PREMIUM LUGGAGE RACK*

The low-profile aerodynamic styling defines the look of this Luggage Rack. Available in mirror-chrome or rich gloss black finish, the die-cast rear "Air Foil" grabs your attention and the Bar & Shield insert adds a signature touch. The elegant round tube rack features inlaid rubber runners for added grip and dedicated bungee mounting points to simplify luggage tie-down. Kit includes all necessary mounting hardware. For added visibility, the rack is designed to incorporate the internal wiring of the Air Foil Rack LED Light Kit P/N 68000076 (red) or 68000077 (smoked) for a clean look.

Fits '04-later XL models equipped with H-D® Detachables™ Sideplates, '06-later Dyna® models (except FXDF, FXDFSE/2 and '10-later FXDWG) equipped with Rigid or Detachable Sideplates, '84-'05 Softail® models (except FXSTD and FLSTN) and '06-later FLST, FLSTC, FLSTNSE and FLSTSC models and '06 FLSTF models equipped with Detachable or Rigid Mount Sideplates.

54290-11	Chrome.	\$209.95
54291-11	Gloss Black.	\$209.95

B. LED LIGHT KIT

Custom fit to the Air Foil Luggage Rack, this fast-acting LED Light Kit operates as a supplemental rear running light and brake light. The high, center-mount position places the light in the line-of-sight of following vehicles and the bright, fast-acting LED lamps get you noticed. Wiring is concealed inside the rack tubes for a clean, custom installation. Available with red or smoked lens.

Fits Air Foil Luggage Rack P/N 54290-11, 54291-11 and Air Wing Sissy Bar Upright P/N 52300146 and 52300147. Installation requires separate purchase of model-specific Wiring Harness Kit.

68000076	Red Lens.	\$44.95
68000077	Smoked Lens.	\$44.95

Also available:

LED LIGHT KIT WIRING HARNESS

Required for installation of LED Light Kit on Air Foil Luggage Rack P/N 54290-11 or 54291-11.

70683-08	\$9.95
-----------------	---------------

Fits '14-later XL models with Air Foil Luggage LED Light Kit P/N 68000076 or 68000077.

69368-11	\$11.95
-----------------	----------------

Fits '04-'13 XL models with Air Foil Luggage LED Light Kit P/N 68000076 or 68000077.

C. CUSTOM TAPERED SPORT LUGGAGE RACK*

Smooth sweeping curves and the brilliant chrome or gloss black finish define the look of this Sport Luggage Rack. Designed to complement both round and square bar Sissy Bar Uprights, this sleek rack adds a practical and stylish touch to the motorcycle.

Fits '04-later XL models equipped with H-D Detachables Sideplates, '06-later Dyna models (except FXDF, FXDFSE/2 and '10-later FXDWG) equipped with Rigid or Detachable Sideplates, '84-'05 Softail models (except FXSTD and FLSTN) and '06-later FLST, FLSTC, FLSTNSE and FLSTSC models and '06 FLSTF models equipped with Detachable or Rigid Mount Sideplates.

50300030	Chrome.	\$139.95
50300031	Gloss Black.	\$139.95



A. AIR FOIL PREMIUM LUGGAGE RACK – CHROME



A. AIR FOIL PREMIUM LUGGAGE RACK – GLOSS BLACK



B. LED LIGHT KIT – RED LENS SHOWN



C. CUSTOM TAPERED SPORT LUGGAGE RACK – CHROME



C. CUSTOM TAPERED SPORT LUGGAGE RACK – GLOSS BLACK



***WARNING:** Do not use this rack as a seat. Do not exceed the fender rack weight capacity. Using as seat or exceeding this capacity could cause handling problems which could result in loss of control and death or serious injury.

Notice: The prices appearing in this catalog are the manufacturer's suggested retail prices. Actual retail prices may vary.



D. TAPERED LUGGAGE RACK – CHROME



D. TAPERED LUGGAGE RACK – GLOSS BLACK



E. SPORT LUGGAGE RACK – FOUR BAR



F. SPORT LUGGAGE RACK – FIVE BAR

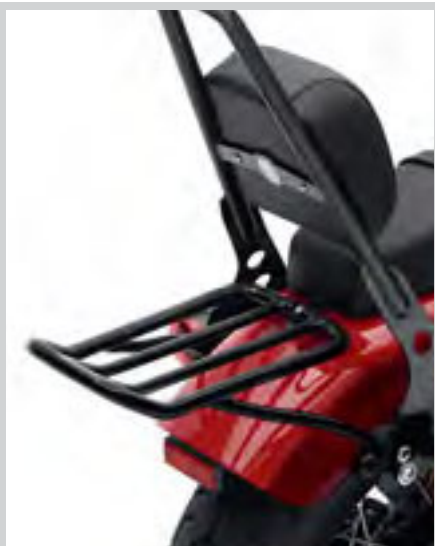

G. CHOPPED FENDER LUGGAGE RACK – GLOSS BLACK



G. CHOPPED FENDER LUGGAGE RACK – CHROME

D. TAPERED LUGGAGE RACK*

Styled to enhance the lines of the motorcycle, this sleek, compact Tapered Rack is an elegant solution for carrying your lunch to work or your luggage across the country.

Fits '04-later XL models equipped with H-D® Detachables™ Sideplates, '06-later Dyna® models (except FXDF, FXDFSE/2 and '10-later FXDWG) equipped with Rigid or Detachable Sideplates, '84-'05 Softail® models (except FXSTD and FLSTN) and '06-later FLST, FLSTC, FLSTNSE and FLSTSC models and '06 FLSTF models equipped with Detachable or Rigid Mount Sideplates.

53718-04	Chrome.	\$119.95
53510-07	Gloss Black.	\$119.95

E. SPORT LUGGAGE RACK – FOUR BAR*

This sleek rack complements the lines of your motorcycle. Can be used with H-D Detachables or Rigid Mount Sissy Bar Sideplates.

53899-02 Chrome. **\$119.95**

Fits '04-later XL models equipped with Rigid Sideplates P/N 53925-04 and '02-'05 Dyna models equipped with Rigid Sideplates or Detachable Sideplates.

53711-96A Chrome. **\$119.95**

Fits '90-'03 XL models with H-D Detachables Sideplate Kit P/N 53545-95, '82-'03 XL models with Rigid Mount Sideplate Kit P/N 52806-94B or 52782-82B, '82-'94 FXR models with Rigid Mount Sideplate Kit P/N 52781-82B (except FXRS-CONV. and FXRT). Fits '96-'01 Dyna models (except FXDWG). All '96-'01 Dyna models equipped with Rigid Mount Sideplates require the separate purchase of Luggage Rack Adapter Kit P/N 53828-00. Also fits '99-'00 FXR models.

F. SPORT LUGGAGE RACK – FIVE BAR*

This rack brings touring flexibility to your motorcycle. Can be used with H-D Detachables or Rigid Mount Sissy Bar Sideplates.

53862-00 Chrome. **\$139.95**

Fits '04-later XL models equipped with Detachable Sideplates, '06-later Dyna models (except FXDF, FXDFSE/2 and '10-later FXDWG) equipped with Rigid or Detachable Sideplates, '84-'05 Softail models (except FXSTD and FLSTN), '06-later FLST, FLSTC and FLSTSC models and '06 FLSTF models equipped with Detachable or Rigid Mount Sideplates. Does not fit with Round Bar Uprights P/N 52300018, 52300020, 52300022 and 52300024.

G. CHOPPED FENDER LUGGAGE RACK*

This Luggage Rack is the ideal option for your ride across town or across the state. Designed for the chopped rear fender, this simple rack adds practical luggage space without compromising style. Rear supports attach to the fender struts and the rack is secured to the passenger pillion mounting point on the rear fender. Available in your choice of chrome or gloss black finish, this rack is compatible with H-D Detachables Uprights and docking hardware.

Fits '09-later XL883N, '07-later XL1200N, XL1200V and XL1200X models.

54250-10 Gloss Black. **\$144.95**

50300040 Chrome. **\$144.95**



***WARNING:** Do not use this rack as a seat. Do not exceed the fender rack weight capacity. Using as seat or exceeding this capacity could cause handling problems which could result in loss of control and death or serious injury.

Notice: The prices appearing in this catalog are the manufacturer's suggested retail prices. Actual retail prices may vary.

94 SPORTSTER®

Backrests & Racks

A. H-D® DETACHABLES™ SOLO RACK*

Add touring capabilities to your solo seat Sportster® model in less than 60 seconds. This detachable Solo Rack fits over the fender when the passenger pillion is removed. The rack features brazed hand-polished tubing and the chrome-plated or gloss black finish adds a stylish flair. Requires Docking Hardware.

Fits '04-later XL models equipped with solo seat. All models (except XL1200T) require separate purchase of appropriate Docking Hardware.

53494-04 Chrome. **\$179.95**

53512-07 Gloss Black. **\$179.95**



A. H-D DETACHABLES SOLO RACK – CHROME

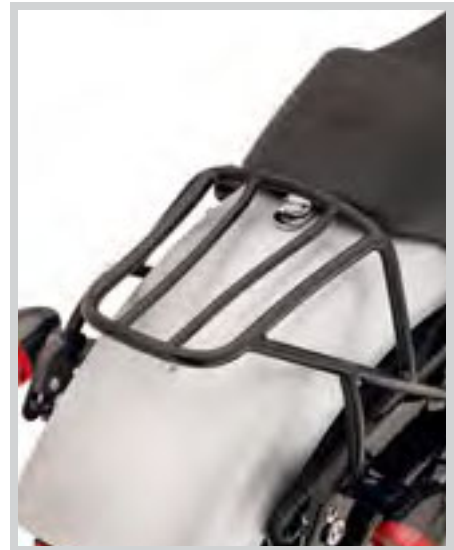

A. H-D DETACHABLE SOLO RACK – GLOSS BLACK

B. XR1200™ LUGGAGE RACK*

Add touring capabilities to your XR1200™ model. This curved black rack complements the sporting lines of the rear fender and the reinforced polymer and steel construction adds strength and durability. Rack features molded tie-down notches that easily accept cargo net or bungee cord hooks for secure loading.

53920-08 **\$139.95**

Fits '08-'13 XR1200 and XR1200X™ models.

Shown with:

XR1200 PASSENGER BACKREST

Add comfort and support for your passenger. Black polymer and steel upright provides a solid mounting point for the form fitted black vinyl backrest pad. Easy to install, the upright bolts into position on Luggage Rack P/N 53920-08 (sold separately).

53976-08 **\$149.95**

Fits '08-'13 XR1200 and XR1200X models. Installation requires separate purchase of Luggage Rack P/N 53920-08.



B. XR1200 PASSENGER BACKREST (SHOWN WITH XR1200 LUGGAGE RACK)



C. XR1200 BUNGEE BARS

C. XR1200 BUNGEE BARS

Secure your soft luggage or spare helmet to the passenger pillion. Bungee Bars provide a solid anchor point for bungee cords or cargo net hooks and protect the fender finish from damage. Black powder-coated steel bars feature formed detents on each side. Kit includes left and right bars and all required mounting hardware.

90363-08 **\$59.95**

Fits '08-'13 XR1200 and XR1200X models.

D. TANK BAG

Shaped to fit the contour of the fuel tank, this ballistic nylon UV- and weather resistant tank bag is your perfect traveling companion. The bag features a clear top pouch for at-a-glance viewing of maps and directions. The rigid body retains its shape – even when empty – and the full-length dual-zippered opening provides easy access. The interior features (2) zippered mesh pouches, (1) quick access nylon pouch and large center cavity for storage of larger items. The internal top pouch adds (3) additional storage slots and (3) pen/pencil holders. Headphone port lets you to “plug in” while keeping your device protected inside the bag. Tank Bag features integrated rain cover with reflective striping. Integrated magnets and soft bottom keep the bag secure to tank while preventing scratches to paint. Quick-release clips allow the bag to be removed for easy access to the fuel filler and the comfortable carrying handle makes transportation a breeze.

93300040 **\$139.95**

Fits '04-later XL models.



D. TANK BAG



***WARNING:** Do not use this rack as a seat. Do not exceed the fender rack weight capacity. Using as seat or exceeding this capacity could cause handling problems which could result in loss of control and death or serious injury.

Notice: The prices appearing in this catalog are the manufacturer's suggested retail prices. Actual retail prices may vary.

E. H-D® DETACHABLES™ LOCKING LEATHER SADDLEBAGS

These large-capacity lockable detachable saddlebags are completely removable with the simple pull of the internal handle, leaving your bike clean and ready to cruise the boulevard. The handsome leather slant-style bags feature hidden quick-release clips behind the classic valise straps and black buckles. When removed, the large capacity bags leave behind two simple, inconspicuous docking points. The bags are compatible with both rigid and H-D® Detachables™ accessories when installed with the appropriate docking hardware kits. Luggage capacity: 2400 cubic inches total.

88358-10 **\$879.95**

Fits '04-later XL models (except XL1200T and XL1200V). Models not equipped with Passenger Pegs require separate purchase of Passenger Footpeg Kit P/N 50203-04 ('04-'13 models) or P/N 50500270 ('14-later models). Domestic XL883N, XL1200N and XL1200X models require License Plate/Directional Relocation Kit P/N 73279-10. International (non-Canadian) XL883N, XL1200N or XL1200X models require Directional Relocation Kit P/N 67800075. '11-later XL1200C models require Directional Relocation Kit P/N 67800071 (Domestic) or 67800077 (International). All other models require separate purchase of Turn Signal Relocation Kit P/N 68732-02A (Domestic), 68733-02A (International) or Layback License Plate Kit P/N 60215-06. Models equipped with Saddlebags only or with Rigid Sideplates require separate purchase of Docking Hardware Kit P/N 53529-04. Models equipped with detachable accessories require separate purchase of Docking Hardware Kit P/N 53529-04 (if not already equipped) and 88390-10. Does not fit with Rear Axle Covers or Bobtail Fender.

Also available:**DOCKING HARDWARE KIT**

Required when installing H-D Detachables accessories with H-D Detachables Saddlebag P/N 88358-10.

88390-10 **\$49.95**

Fits '04-later XL models (except XL1200T and XL1200V).

Also available:**LICENSE PLATE/DIRECTIONAL RELOCATION KIT**

Required when installing certain XL Saddlebags on models originally equipped with side-mount license plate.

73279-10 **\$209.95**

Fits '07-later XL883N, XL1200N, XL1200V and XL1200X models with side-mounted license plate and equipped with XL Saddlebag Kit P/N 53050-10, 88358-10 or 90342-04A.

Also available:**DIRECTIONAL RELOCATION KIT**

Kit moves turn signals from rear fender struts to a license bracket-mounted turn signal bar. Required for installation of fixed mount or detachable saddlebags on XL1200C models.

67800071 Domestic. **\$99.95**

Fits '11-later XL1200C Domestic models.



E. H-D DETACHABLES LOCKING LEATHER SADDLEBAGS – INSTALLED



E. H-D DETACHABLES LOCKING LEATHER SADDLEBAGS – REMOVED

96 SPORTSTER®

Saddlebags & Luggage

A. RIGID LEATHER LOCKING SADDLEBAGS

These premium textured leather saddlebags are ready to go the distance. The push-button latching swing-out lid is easy to operate with one hand and the fine leather surface and brushed chrome medallion add an elegant touch. The hard-shell design retains its shape in all kinds of weather and is covered in leather for a traditional look. Locking hinged lids offer modern convenience and security. Styled to complement the sleek, narrow Sportster® profile, these bags offer plenty of storage for a trip across town or across the country. Kit includes reflectors. Luggage Capacity: 2400 cubic inches total.

53050-10 **\$729.95**

Fits '04-later XL models (except XL1200T, XL1200V and International (non-Canadian) XL883N, XL1200N or XL1200X models). Domestic XL883N, XL1200N and XL1200X models require License Plate/Directional Relocation Kit P/N 73279-10. '11-later XL1200C models require Directional Relocation Kit P/N 67800071 (Domestic) or 67800077 (International). All other models require separate purchase of Turn Signal Relocation Kit P/N 68732-02A (Domestic), 68733-02A (International) or Layback License Plate Kit P/N 60215-06. Models equipped with H-D® Detachables™ accessories require separate purchase of Docking Hardware Kit P/N 53544-04. Does not fit with Rear Axle Covers or Bobtail Fender.



A. RIGID LEATHER LOCKING SADDLEBAGS

B. SPORTSTER® LEATHER SADDLEBAGS

These saddlebags are constructed from 9 oz. leather with thermoformed backs for added shape retention. Bags feature an embossed "Sportster" script logo for style and quick-disconnect clips under traditional chrome buckles for easy access. Luggage capacity: 3000 cubic inches total.

90342-04A **\$659.95**

Fits '94-later XL models (except '02-'03 XL883R, XL1200S, XL1200T and models equipped with Rear Axle Covers, Flat Lens Turn Signals, accessory Bullet Style Turn Signals P/N 68005-99 and 68637-99 or '04-later models equipped with Bobtail fender or detachable sideplates). '04-later models (except XL883N, XL1200N, XL1200V and XL1200X models with side-mounted license plates) require separate purchase of Directional Relocation Kit P/N 68474-04B (chrome) or 73281-10 (black). XL883N, XL1200N, XL1200V and XL1200X models with side-mounted license plates require separate purchase of License Plate/Directional Relocation Kit P/N 73279-10. International (non-Canadian) XL883N, XL1200N, XL1200V and XL1200X models require separate purchase of Directional Relocation Kit P/N 67800075. '11-later XL1200C models require purchase of Turn Signal Relocation Kit P/N 67800071 (Domestic) or 67800077 (International). '94-'03 models require separate purchase of Directional Relocation Kit P/N 68485-04. '94-'03 models equipped with H-D Detachables accessories require separate purchase of Docking Hardware Kit P/N 90465-98A or 53532-02.



B. SPORTSTER LEATHER SADDLEBAGS

C. SYNTHETIC LEATHER SADDLEBAGS

Combine street attitude with long-haul versatility and you get these custom bags. Styled with sweeping lines to complement the Sportster fender, these bags feature plenty of storage space for a ride to the store or to Sturgis. The rigid plastic tub, wrapped in rich synthetic leather, offers long-term durability. The traditional straps hide quick-disconnect closures for packing convenience and the chrome buckles provide a look that's pure Harley-Davidson. Luggage capacity: 2000 cubic inches total.

90330-08 **\$429.95**

Fits '04-later XL models (except XL883N, XL1200N, XL1200T, XL1200V, XL1200X, '02-'03 XL883R, models equipped with Rear Axle Nut covers or Flat Lens Turn Signals and models equipped with 2-into-1 exhaust). '04-later models require separate purchase of Turn Signal Relocation Kit P/N 68732-02A (Domestic), P/N 68733-02A (International) or Layback License Plate Kit P/N 60215-06. '11-later XL1200C fitment requires purchase of Turn Signal Relocation Kit P/N 67800071 (Domestic) or 67800077 (International).



C. SYNTHETIC LEATHER SADDLEBAGS

Notice: The prices appearing in this catalog are the manufacturer's suggested retail prices. Actual retail prices may vary.



D. "EXPRESS RIDER" LARGE CAPACITY LEATHER SADDLEBAGS

D. "EXPRESS RIDER" LARGE CAPACITY LEATHER SADDLEBAGS

Traditional "pony express" throw-over bag styling is enhanced with a modern rigid mounting structure on this handsome set of leather saddlebags. This Large Capacity Sportster® saddlebag offers the convenience of quick-release clips under conventional buckles for easy access. The riveted leather patch with embossed Bar & Shield logo completes the ageless look. Luggage capacity: 2400 cubic inches total.

88312-07A **\$529.95**

Fits '04-later XL models (except XL1200T, XL1200V and International (non-Canadian) XL883N, XL1200N or XL1200X models). Domestic XL883N, XL1200N and XL1200X models require License Plate/Directional Relocation Kit P/N 73279-10. '11-later XL1200C models require Directional Relocation Kit P/N 67800071 (Domestic) or 67800077 (International). All other models require separate purchase of Turn Signal Relocation Kit P/N 68732-02A (Domestic), 68733-02A (International) or Layback License Plate Kit P/N 60215-06. Models equipped with Detachable accessories require separate purchase of Docking Hardware Kit P/N 53544-04 (if not already equipped). Does not fit with Rear Axle Covers or Bobtail Fender.

E. LEATHER THROW-OVER SADDLEBAGS

These traditional Leather Throw-Over bags feature large side gussets for increased capacity and full-length straps with hidden quick-disconnect clips for easy access.

91008-82C **\$369.95**

Fits '82-later XL (except XL1200T), '08-later Dyna® (except FLD) and '84-'99 Softail® models equipped with H-D® Chrome Saddlebag Supports.

F. SYNTHETIC LEATHER THROW-OVER ADJUSTABLE SADDLEBAGS

Synthetic leather with embossed "Eagle Wing" logo. 11.0" H x 10.0" W x 3.75" D.

90570-86TA **\$119.95**

Fits '82-'03 XL, '91-'05 Dyna and '84-'99 Softail models equipped with Saddlebag Supports.

G. CHROME SADDLEBAG SUPPORTS

Fit with or without Sissy Bar Uprights, attach easily and protect bags from contacting brake and swingarm.

90799-94D **\$99.95**

Fits '94-later XL models (except XL1200S, XL1200T and '02-'03 XL883R). Does not fit with H-D® Detachables™. (Includes Chrome Upper Shock Covers P/N 54711-94.)



E. LEATHER THROW-OVER SADDLEBAGS



F. SYNTHETIC LEATHER THROW-OVER ADJUSTABLE SADDLEBAGS



G. CHROME SADDLEBAG SUPPORTS

Notice: The prices appearing in this catalog are the manufacturer's suggested retail prices. Actual retail prices may vary.

98 SPORTSTER®

Saddlebags & Luggage

A. HARD SADDLEBAGS*

Sporty is the best way to describe any Sportster® model decked out with these lockable bags. These hard bags use injection-molded construction. Kit includes Turn Signal Relocation Hardware. Luggage capacity: 2,500 cubic inches total.

Fits '04-later XL models (except XL883N, XL1200N, XL1200T, XL1200V, XL1200X). Installation on vehicles equipped with H-D® Detachables™ Sissy Bar or Luggage Rack requires the separate purchase of Mounting Hardware Kit, '04-later models require Hardware Kit P/N 91405-04.

91412-04BDK	Primed.	\$1,249.95
91412-04AV	Birch White.	\$1,499.95
91412-04DH	Vivid Black.	\$1,499.95



A. HARD SADDLEBAGS

B. SPORT TOUR-PAK® LUGGAGE*

Designed to complement the styling of the Softail® and Sportster Hard Saddlebags, the Sport Tour-Pak® Luggage adds increased storage for your ride across town or across the country. The injection molded Tour-Pak Luggage is lockable and includes an interior rubber mat. Large enough to store most full-faced helmets. Racks and docking kits sold separately. International models may require separate purchase of License Plate Relocation Kit P/N 60095-00A. Luggage capacity: 2245 cubic inches.

Fits '04-later XL models (except XL883N, XL1200C and XL1200N) equipped with Solo Seat and Solo Tour-Pak® Rack. Fits '00-'05 Softail® models (except Deuce™) and '06 FLST, FLSTF, and '06-later FLSTC, FLSTN, FLSTSC models equipped with H-D Detachables Solo or Two-Up Tour-Pak Rack. Fits '97-'08 Touring models equipped with Detachable Two-Up or Solo Tour-Pak Racks.

53929-12BDK	Primed.	\$569.95
53929-06AV	Birch White.	\$749.95
53929-06DH	Vivid Black.	\$749.95

C. BACKREST PAD FOR SPORT TOUR-PAK LUGGAGE

52872-01 **\$104.95**
Fits models equipped with Color-Matched Sport Tour-Pak Luggage.

D. H-D® DETACHABLES™ SOLO TOUR-PAK MOUNTING RACK**

The Solo Tour-Pak Rack places the Sport Tour-Pak in a comfortable back-supporting position. The rack is designed to position the Tour-Pak for solo riding. Simply remove the Tour-Pak Rack from the convenient docking hardware, add a passenger pillion and the bike is ready for two-up riding. Tour-Pak, Passenger Backrest Pad and Docking Hardware sold separately.

53655-04 **\$139.95**
Fits '04-later XL models equipped with solo seat (except XL883N, XL1200C, XL1200N). Designed to accept Color-Matched Sport Tour-Pak P/N 53929-YYXXX, Leather Tour-Pak P/N 53151-00A, 53147-98B, 53018-04A or 53690-06A. Requires separate purchase of appropriate Docking Hardware.



B. SPORT TOUR-PAK LUGGAGE
(SHOWN WITH H-D DETACHABLES SOLO TOUR-PAK RACK AND BACKREST PAD)



C. BACKREST PAD FOR
SPORT TOUR-PAK LUGGAGE



D. H-D DETACHABLES SOLO TOUR-PAK
MOUNTING RACK

*NOTE: This product is a "Paint to Order" accessory. Please allow for an average of 5 weeks delivery for this item.



****WARNING:** Do not use this rack as a seat. Do not exceed the fender rack weight capacity. Using as seat or exceeding this capacity could cause handling problems which could result in loss of control and death or serious injury.

Notice: The prices appearing in this catalog are the manufacturer's suggested retail prices. Actual retail prices may vary.



E. TOUR-PAK LUGGAGE
(SHOWN WITH H-D DETACHABLES SOLO TOUR-PAK MOUNTING RACK)

E. TOUR-PAK® LUGGAGE

Add cross-country luggage capacity to your ride with accessory Tour-Pak® Luggage. A cavernous interior will hold one full face helmet or two half helmets. Kit includes backrest pad, interior rubber mat, hardware and instructions. Luggage capacity: 2500 cubic inches. Dimensions: 18.5" W x 17.0" D x 13.0" H. Racks and docking kits sold separately. International models may require separate purchase of License Plate Relocation Kit P/N 60095-00A.

53690-06A Smooth Vinyl. **\$514.95**

Fits '04-later XL models (except XL883N, XL1200C, XL1200N) equipped with Solo Tour-Pak® Rack. Fits '00-later Softail® models (except FLS, FLSTNSE, FLSTSE/2/3, FXCW, FXCWC, FXS, FXSB, FXSBSE, FXSTD, FXSTSSE3) equipped with H-D® Detachables™ Solo or Two-Up Tour-Pak Rack. Fits '97-'13 Touring models (except Trike) equipped with Detachable Two-Up or Solo Tour-Pak Racks.

F. SINGLE-SIDED SWINGARM BAG

Less is more. With enough room for the essentials, these stylish Swingarm Bags eliminate the need to stuff your pockets or bungee a bag across the passenger pillion. Shaped to hug the contour of your bike's frame, these compact bags add an old-school look. Bags are constructed of heavyweight leather and feature a pouch-style flap lid that is secured with two quick-disconnect clips that are hidden behind traditional straps and buckles. The semirigid-backed bag is secured to the left side of the bike with easy-to-install brackets and adjustable straps. Luggage capacity: 430 cubic inches total.

Fits '04-later XL models equipped with solo seats. Requires removal of passenger pegs. XL1200T models require removal of Original Equipment saddlebags and passenger pegs.

90200572 Black Leather. **\$199.95**

90200573 Brown Distressed Leather. **\$199.95**

G. DOWN-TUBE BAG

The perfect place to store a couple of tools, a tire gauge or your disc lock. The rigid-backed bag features a stylish heavy leather flap and traditional strap-and-buckle closures to provide both function and flair. Easy-to-install, the low frame placement is inconspicuous, but still provides quick access when needed. Kit includes all required mounting hardware.

Fits '04-later XL, XR and '06-later Dyna® models (except FLD). Does not fit XL models with engine guard. Does not fit XL models with Boom!™ Audio Cruiser Amp and Speaker Kit P/N 76262-08 or 76320-08. Does not fit Dyna models with evaporative emissions canister (California and AP markets). Does not fit with Dyna Oil Cooler Kit P/N 26151-07. Does not fit XL and Dyna models equipped with Front Spoilers. FXDSE/2 and FXDFSE/2 models require removal of Original Equipment front spoiler.

93300044 Black Leather. **\$129.95**

93300045 Brown Distressed Leather. **\$129.95**



F. SINGLE-SIDED SWINGARM BAG – BLACK LEATHER



F. SINGLE-SIDED SWINGARM BAG – BROWN DISTRESSED LEATHER



G. DOWN-TUBE BAG – BLACK LEATHER



G. DOWN-TUBE BAG – BROWN DISTRESSED LEATHER

Notice: The prices appearing in this catalog are the manufacturer's suggested retail prices. Actual retail prices may vary.

100 SPORTSTER®

Saddlebags & Luggage

A. UNIVERSAL SADDLEBAG LOCK KIT

Keep the contents of your existing soft-sided saddlebags safe from the grab-and-go thief. This unique kit features two extra-small barrel locks that can replace existing saddlebag snaps to perform double duty as locks or as snaps when you don't need to lock your bags. Can be keyed to match your barrel-style ignition key. Sold in pairs.

Fits most soft-sided leather and vinyl saddlebags. Does not fit FLHRC and FLHRS.

90300003	Keyed To Match.	\$59.95
90300017	Random Key Code.	\$49.95



A. UNIVERSAL SADDLEBAG LOCK KIT

B. SADDLEBAG TRAVEL-PAKS

Water-resistant liners make packing easy. Feature inner pockets for extra storage and an embroidered Bar & Shield logo.

91959-97	\$54.95
-----------------	----------------

Liner dimensions: 12.0"W x 10.0"T x 5.0"D.

91486-01	\$49.95
-----------------	----------------

Fits XL models and Dyna® models equipped with Color-Matched Hard Saddlebags.



B. SADDLEBAG TRAVEL-PAKS
(91959-97 SHOWN)

C. TANK BRA

This Tank Bra is made with non-abrasive, fleece-backed vinyl material and features an embroidered Bar & Shield logo. It protects your fuel tank from scratches from keys, belt buckle, etc. Designed for easy installation and a custom fit without disassembly of the tank or seat.

62027-04	\$42.95
-----------------	----------------

Fits '04-later XL models equipped with 4.5 gallon fuel tank.

62030-04	\$44.95
-----------------	----------------

Fits '04-later XL models equipped with 3.3 gallon fuel tank.

61929-98	\$44.95
-----------------	----------------

Fits '97-'03 XL models equipped with 3.3 gallon fuel tanks.

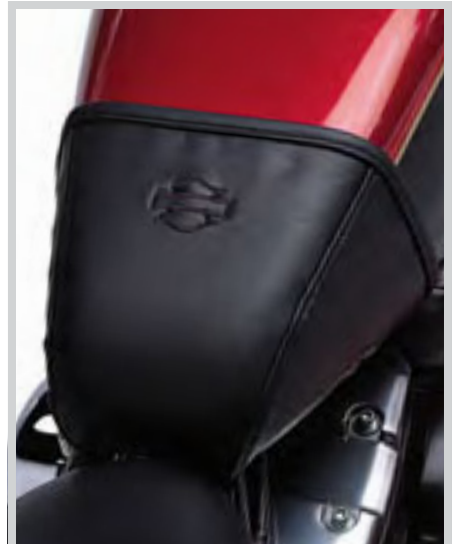

C. TANK BRA

D. AUXILIARY POWER PORT – SADDLEBAG MOUNT

Charge your cell phone or portable music player from this handy saddlebag-mounted 12-volt power port. Conventional "cigarette lighter" style power outlet accepts most 12V automotive power adaptor plugs and features a flip-top cover to protect the port while not in use.

69200091	\$40.95
-----------------	----------------

Fits models equipped with 12-volt battery. Does not fit VRSC™ models, Throw-Over or Swingarm Bags. Not for use with accessory Fitted Liners or Premier Liners. Requires separate purchase of Battery Charging Harness P/N 94624-97B, if not already equipped.

E. USB CHARGING ADAPTOR

Charge your cell phone, MP3 players and other hand-held devices while on the road. Compact Adaptor plugs into standard and accessory "cigarette lighter" 12-volt power ports and provides a standard USB-style outlet that accepts many phone and music player power cords.

69200357	\$19.95
-----------------	----------------

For use with 12V Auxiliary Power Port.



D. AUXILIARY POWER PORT –
SADDLEBAG MOUNT



E. USB CHARGING ADAPTOR

Notice: The prices appearing in this catalog are the manufacturer's suggested retail prices. Actual retail prices may vary.

A STRONG FOUNDATION

Being sure-footed at a stop or when parking your bike enhances your feeling of control and confidence. Adjusting the ride height by lowering the suspension may be the first step in fitting the bike to your inseam length. Combining a low-profile suspension and a narrow seat is the easiest way for a shorter rider to fit comfortably on a larger bike.

SUSPENSION

While most current Sportster® models are already equipped with low-profile suspension, Harley® offers optional two-up shocks that maintain the low ride height and add additional carrying capacity. Or, if you are willing to exchange the low-profile "slammed" look for improved ride comfort, Comfort Flex standard-length shocks deliver an improved ride through a longer stroke.



ESTABLISH YOUR POSITION



HANDLEBARS

Where the bar positions your hands, wrists and arms directly affects how you feel on the motorcycle. The shape of the bar determines your reach to the hand controls and, therefore, your overall comfort.



SEATS

The right seat is equal parts ergonomics and comfort. Its shape anchors your position and determines the reach to the ground and to the controls and the padding supports your tailbone and hips to relieve stress and pressure. Pick the right one for you – and your passenger.



FOOT CONTROLS

Where your feet contact the controls can often determine how many miles you can put on in a day. Mid-controls position your feet below the knee for a sporting riding posture, while forward controls stretch your legs for a relaxed, laid-back posture.

THE FIT SHOP LIST	2015	SUSPENSION	SEATS	HANDLEBARS	FOOT SUPPORTS
 <p>Here are a few options to consider when outfitting your bike to fit you. Find your model and flip to the pages for more information. For more details, visit h-d.com/fitshop.</p>	XL883N	Low Suspension is Stock Two-Up Profile® Low Rear Shocks Comfort Flex Rear Shocks	Reduced Reach® Seats Brawler®/Sidekick® Seat Badlander® Seat Road Zeppelin® Seat	Mini-Ape Handlebar Drag Bar Chizeled Bar	Further Forward Mid-Controls Reduced Reach Forward Controls Forward Control Kit Adjustable Highway Pegs Adjustable Passenger Pegs
	XL883L XL1200T	Low Suspension is Stock Two-Up Profile Low Rear Shocks	Reduced Reach Seats Brawler/Sidekick Seats Badlander Seat Road Zeppelin Seat	Mini-Ape Handlebar Chizeled Bar Iron 883™ Handlebar	Further Forward Mid-Controls Reduced Reach Forward Controls Forward Control Kit Adjustable Highway Pegs Adjustable Passenger Pegs
	XL1200C	Low Suspension is Stock Two-Up Profile Low Rear Shocks Comfort Flex Rear Shocks	Reduced Reach Seats Brawler / Sidekick Seats Badlander Seat Road Zeppelin Seat	Reduced Reach Bar Iron 883 Handlebar	Further Forward Mid-Controls Reduced Reach Forward Controls Adjustable Passenger Pegs
	XL1200V	Low Suspension is Stock Two-Up Profile Low Rear Shocks Comfort Flex Rear Shocks	Reduced Reach Seats Brawler / Sidekick Seats Badlander Seat Road Zeppelin Seat	Mini-Ape Handlebar Drag Bar Chizeled Bar Iron 883 Handlebar	Further Forward Mid-Controls Reduced Reach Forward Controls Adjustable Passenger Pegs
	XL1200X	Low Suspension is Stock Two-Up Profile Low Rear Shocks Comfort Flex Rear Shocks	Reduced Reach Seats Brawler / Sidekick Seats Badlander Seat Road Zeppelin Seat	Mini-Ape Handlebar Chizeled Bar Hollywood Handlebar	Further Forward Mid-Controls Reduced Reach Forward Controls Adjustable Passenger Pegs

102 SPORTSTER®

Suspension

A. PROFILE® LOW FRONT SUSPENSION KIT*

This kit is designed to lower the front suspension by approximately 1.0" while preserving the ride quality. The shorter fork springs are progressively wound to allow a compliant, controlled ride. A perfect addition during the installation of chrome or gloss black lower fork sliders, kit includes two fork springs and damper tubes.

45500-09 **\$104.95**

Fits '09-'10 XL883, XL883C, XL883R, XL1200C and XL1200R models. '09-'10 XL883, XL883R and XL1200R models must also have Low Rear Shock Kit P/N 54754-09 installed.

45480-05 **\$104.95**

Fits '04-'08 XL models (except '07-'08 XL883L and XL1200N). Stock on '04-'06 XL883L and '06-'08 XL1200L models. XL883, XL883R, and XL1200R models must also have Low Rear Shock Kit P/N 54750-05A, 54731-04, or 54733-04 installed.



**A. PROFILE LOW FRONT SUSPENSION KIT
(P/N 45500-09 SHOWN)**



**A. PROFILE LOW FRONT SUSPENSION KIT
(P/N 45480-05 SHOWN)**

B. PROFILE LOW REAR SHOCK KIT*

Plant your feet firmly on the ground. This reduced length version of the Original Equipment rear suspension lowers the seat height by approximately 1.0". Shocks feature chrome-plated springs and body caps, and suspension preload is adjustable for rider and passenger load.

54754-09 **\$224.95**

Fits '06-'10 XL883, XL883R and XL1200R models. Stock on '09-'10 XL883C, '09-later XL1200C and XL1200L. Kit includes shorter jiffy stand.

54733-04 **\$224.95**

Fits '91-'05 XL883, XL883DLX, XL883R and XL1200 models. Does not lower XL Custom, XL883L, XL1200L, XL 50th Anniversary or Hugger™ models.

C. TWO-UP PROFILE LOW REAR SHOCK KIT*

These heavy-duty shocks are tuned for the touring rider carrying a passenger or loaded saddlebags. Shock length and spring rate are engineered to maintain the factory low seat height. The chrome-bodied shocks feature adjustable preload for a comfortable, controlled ride.

54704-07 **\$224.95**

Fits '07-later XL883L, XL883N, XL1200N, XL1200V, XL1200X and '11-later XL1200C models.



**B. PROFILE LOW REAR SHOCK KIT
(P/N 54733-04 SHOWN)**



C. TWO-UP PROFILE LOW REAR SHOCK KIT

D. SPORTSTER® COMFORT FLEX REAR SHOCKS*

For the rider willing to exchange the low-profile "slammed" look for improved ride comfort. Standard-length shocks raise the seat height of a factory-lowered bike approximately 1.0" and deliver an improved ride through a longer stroke. Spring rates and damping are tailored to ensure a controlled ride and optimal performance under varying conditions. Kit includes left and right rear shock absorbers.

54000040 **\$224.95**

Fits '11-later XL1200C, XL1200V, '08-later XL1200L, '07-later XL883N, XL883R, XL1200N, XL1200X, XL50, and '05-'10 XL883L models. Stock on International models of XL883N and XL1200N in HDI, ENG, AUS and APC markets. Cannot be used on models equipped with Profile® Low Front Suspension Kits.



D. SPORTSTER COMFORT FLEX REAR SHOCKS



***WARNING:** The Profile Low Front Spring Kit cannot be used independently and must be used with the appropriate Profile Rear Shock Lowering Kit. Installation of any accessory suspension components may affect cornering clearance and jiffy stand operation. This could distract the rider, causing loss of control and death or serious injury.



***WARNING:** Installation of any accessory suspension components may affect cornering clearance and jiffy stand operation. This could distract the rider, causing loss of control and death or serious injury.

Notice: The prices appearing in this catalog are the manufacturer's suggested retail prices. Actual retail prices may vary.

SPORTSTER® 103

Foot Controls



E. ADJUSTABLE HIGHWAY PEG SUPPORT KIT



E. ADJUSTABLE HIGHWAY PEG SUPPORT KIT*

So you're not your average Sportster® motorcycle rider. But then again, there is nothing average about Harley-Davidson. These chrome-plated Highway Peg Supports adjust easily and quickly into three height-accommodating positions. Use with your choice of H-D® small male mount-style footpegs (not included). Includes all necessary hardware.

49053-04A **\$199.95**

Fits '04-later XL models with mid controls.

F. JIFFY STAND EXTENSION

Jiffy Stand Extension kits have been ergonomically designed to simplify the deployment and retraction of the jiffy stand. The extension is shaped to simplify locating the tab with your boot and aid in swinging the jiffy stand into position. The move feels natural and adds confidence when parking your motorcycle in a tight spot. Kit mounts to Original Equipment jiffy stand and includes all required mounting hardware.

50462-11 Black. **\$34.95**

Fits '07-later XL and XR models (except XL50, XL883C, XL1200L, XL1200T, XL1200V, '09-'10 XL1200C, '07-'08 XL883, XL883R and XL1200R). Does not fit '09-later XL883N, XL1200X and XL1200N for International markets AUS, BRZ, ENG and HDI.

50250-04 Chrome. **\$44.95**

Fits '04-later XL1200V, '04-'13 XL883C, XL1200L and '04-'10 XL1200C models. Also fits XL883N and XL1200N models for International markets AUS, BRZ, ENG, HDI and India.

G. CUSTOM GEAR SHIFT LINKAGES

Kick your custom into gear with this collection of high-quality Custom Shift Linkages. Available in a variety of designs to match your bike's style, these linkages feature aircraft quality rod ends for easy adjustment and smooth operation. The easy-to-install linkage kit includes decorative bolts for a complete custom look.

Fits '04-later XL models equipped with standard forward controls.

1. 34840-09 Skull. **\$109.95**

2. 33778-09 Black Anodized Slotted Linkage. **\$99.95**

3. 33900102 Silencer Brushed Nickel. **\$99.95**

H. GEAR SHIFT LEVER – CHROME

Shift in style with this brilliant, chrome-plated shift lever. Complete the look with a custom shifter peg.

34606-90T **\$62.50**

Fits '91-'03 XL models (except models equipped with forward controls).



F. JIFFY STAND EXTENSION – BLACK



F. JIFFY STAND EXTENSION – CHROME



G. CUSTOM GEAR SHIFT LINKAGES



H. GEAR SHIFT LEVER – CHROME

Notice: The prices appearing in this catalog are the manufacturer's suggested retail prices. Actual retail prices may vary.

104 SPORTSTER®

Foot Controls

A. FORWARD CONTROL KIT*

Add the stretched-out look and extended riding position to your Sportster® model. The complete kit includes all hardware necessary to convert your Sportster model from mid-controls to forward controls. Available in your choice of finishes, these forward controls add style and long range comfort. (Footpegs and shifter peg not included.)

Fits '14-later XL models. Requires separate purchase of stock or accessory rider position footpegs with wear pegs that fit '14-later XL1200 models.

50700020 Chrome. **\$469.95**

50700021 Black. **\$399.95**

Fits '06-'13 XL models with mid-controls. XL1200L requires separate purchase of footpegs P/N 33134-07CAZ and 33135-07CAZ.

33395-06A Chrome. **\$449.95**

33398-06A Polished. **\$399.95**

33397-07A Black. **\$399.95**

Fits '04-'05 XL models. Does not fit with 2-into-1 Exhaust Systems.

33395-04 Chrome. **\$449.95**

33398-04 Polished. **\$399.95**

Fits '91-'03 XL (except XL883R). Does not fit with 2-into-1 Exhaust Systems. Current owners of Engine Guard P/N 49018-88A and 49018-88B will need to purchase bracket P/N 49014-86A for proper fitment (sold separately). This kit will not fit on vehicles equipped with an early style engine guard. Use Engine Guard Kit P/N 49018-88C when adjustable highway peg supports are installed.

33891-98 Chrome. **\$499.95**

33892-98 Polished. **\$399.95**

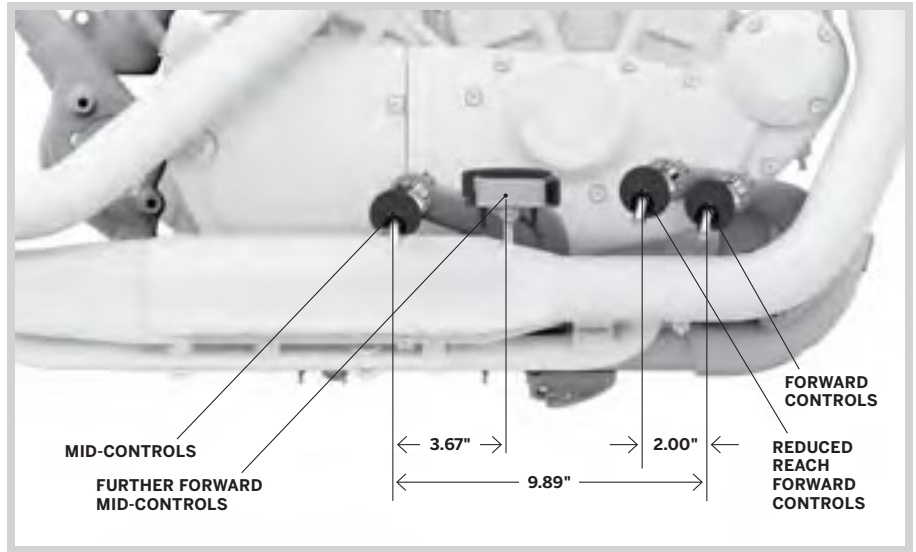

FOOT CONTROL POSITION COMPARISON



A. FORWARD CONTROL KIT – CHROME



A. FORWARD CONTROL KIT – BLACK



***WARNING:** Installation of accessory Forward Control Kits may affect cornering clearance. This could distract the rider, causing loss of control, resulting in death or serious injury.

Notice: The prices appearing in this catalog are the manufacturer's suggested retail prices. Actual retail prices may vary.

SPORTSTER® 105

Foot Controls



NEW



NEW

B. REDUCED REACH FORWARD CONTROL CONVERSION KIT (50700026 SHOWN)

B. REDUCED REACH FORWARD CONTROL CONVERSION KIT*

Love the look and riding position you get with forward controls but not comfortable with the long stretch forward? This Forward Control Conversion Kit repositions the Original Equipment footpegs and foot controls up and back by 2.0" and positions the controls closer to the rider for added comfort and confidence. This kit provides additional leg clearance around the chassis and air cleaner by moving the footpegs outward 1.5" (left) and 0.5" (right). The reduced reach places the rider's boot at the proper pivot point for improved leverage, while maintaining the "foot-forward" riding profile. This easy-to-install Conversion Kit includes heavy-duty steel mounts and shortened brake rod and reuses Original Equipment control supports and brake and shift levers or can be personalized with your choice of custom lever styles.

50700010 **\$179.95**

Fits '04-'13 XL models equipped with forward controls.

50700026 **\$249.95**

Fits '14-later XL models equipped with forward foot controls.

C. FURTHER FORWARD MID-CONTROL KIT

Feel a little cramped when your feet are placed on the standard-location mid-controls? This kit repositions the controls 3.0" forward of the stock location, eliminating the "knees-high" riding attitude while maintaining a sporty upright riding posture. The forward location provides an open path for your feet to aid maneuvering the bike while parking and improves access to the jiffy stand for a shorter rider. Kit includes control mounts, brake and shift levers, brake rod, mini-footboards with wear pegs and all hardware necessary to convert your mid- or forward-control equipped Sportster® model.

Fits '14-later XL models.

50700027 Chrome. **\$469.95**

50700028 Gloss Black. **\$399.95**



NEW



NEW

C. FURTHER FORWARD MID-CONTROL KIT – CHROME



NEW



NEW

C. FURTHER FORWARD MID-CONTROL KIT – GLOSS BLACK



***WARNING:** Installation of accessory Forward Control Kits may affect cornering clearance. This could distract the rider, causing loss of control, resulting in death or serious injury.

Notice: The prices appearing in this catalog are the manufacturer's suggested retail prices. Actual retail prices may vary.

SPORTSTER

106 SPORTSTER®

Engine Guards

A. ENGINE GUARD*

The unique soft curve shape adds style to function. The one-piece Engine Guard is designed to complement the lines of the Sportster® motorcycle and the choice of finishes adds the perfect finishing touch. Add your choice of Engine Guard Mounted Highway Pegs (sold separately) to change your foot position on a long ride.

Fits '04-later XL and XR models (except XL1200T and '11-later XL883L). (Will not fit with Front Spoilers.)

49060-04 Chrome. **\$214.95**

49215-07 Gloss Black. **\$214.95**

Fits '11-later XL883L and '14-later XL1200T models. (Will not fit with Front Spoilers.)

49287-11 Chrome. **\$214.95**

B. SOFT LOWERS

Extend your riding season. Full coverage Soft Lower provide wind and mud protection for the rider's legs and boots and minimize cold updrafts as the weather changes. Covers are custom shaped to hug the engine guard to minimize flapping and they clip in place for speedy installation as the weather changes. Two-way zippered outer edge accommodates guard-mounted highway pegs in almost any position. Reflective piping provides added visibility and convenient zippered pockets provide additional storage for maps or other small items.

57100211 **\$89.95**

Fits '04-later XL models (except '11-later XL883L and '14-later XL1200T) equipped with Engine Guard P/N 49060-04 or 49215-07. Does not fit Mustache Engine Guards.



A. ENGINE GUARD – CHROME



A. ENGINE GUARD – GLOSS BLACK



B. SOFT LOWERS



B. SOFT LOWERS



***WARNING:** Engine guards may provide limited leg and cosmetic vehicle protection under unique circumstances (fall over while stopped, very low speed slide). They are not made nor intended to provide protection from bodily injury in a collision with another vehicle or any other object.

Notice: The prices appearing in this catalog are the manufacturer's suggested retail prices. Actual retail prices may vary.

SPORTSTER® 107

Engine Guards

C. MUSTACHE ENGINE GUARD*

Combine classic shape and modern function for a unique twist on engine protection. The flow of this Engine Guard complements the bike's traditional style while the gracefully curved upper section incorporates highway pegs into the shape. The integrated rubber pads offer a comfortable and slip-resistant cushion for your feet while traveling the open road. One-piece engine guard kit includes all required mounting hardware.

Fits '04-later XL and XR models. (Will not fit with Front Spoilers.)

49000005 Chrome. **\$269.95**

49000006 Gloss Black. **\$269.95**

D. ENGINE GUARD*

This highly-polished, chrome-plated guard matches stock plating and works great with the Sportster® Forward Controls.

49018-88C Chrome. **\$219.95**

Fits '84 1/2-'03 XL models. (Will not fit with Front Spoilers.)

(NOTE: '82-early '84 models require Bracket P/N 49014-85.)



C. MUSTACHE ENGINE GUARD – CHROME



C. MUSTACHE ENGINE GUARD – BLACK

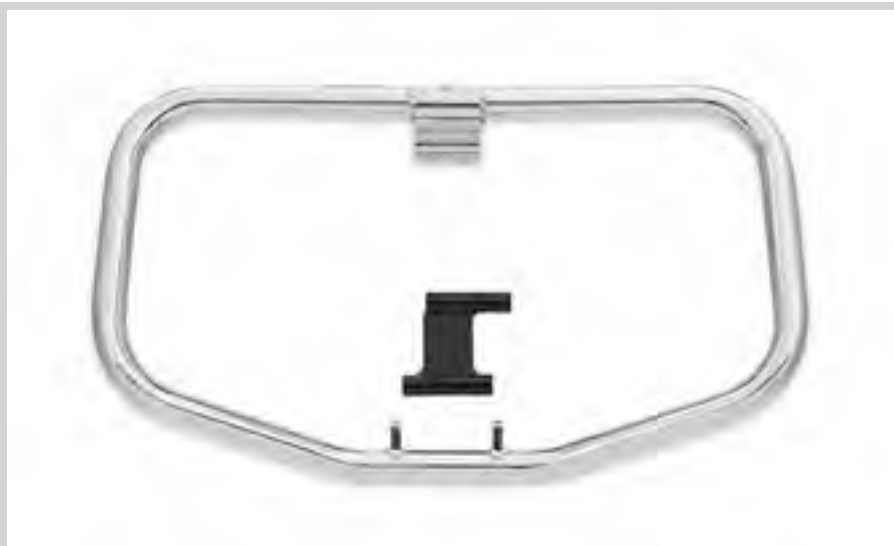

D. ENGINE GUARD – CHROME



***WARNING:** Engine guards may provide limited leg and cosmetic vehicle protection under unique circumstances (fall over while stopped, very low speed slide). They are not made nor intended to provide protection from bodily injury in a collision with another vehicle or any other object.



***WARNING:** Do not use engine guard footpegs under normal stop and go operating conditions. Doing so could result in death or serious injury.

Notice: The prices appearing in this catalog are the manufacturer's suggested retail prices. Actual retail prices may vary.

108 SPORTSTER®

Foot Controls

A. PASSENGER FOOTPEG MOUNT KIT – BLACK

A necessary addition when converting your solo seat Sportster® to a two-up passenger-carrying ride. Kit includes black mounting brackets, Original Equipment-style footpegs and all necessary mounting hardware.

50500270 **\$114.95**

Fits '14-later XL models.

50203-04 **\$114.95**

Fits '04-'13 XL models.

B. PASSENGER FOOTPEG MOUNT KIT – CHROME

Nicely complements any passenger footpeg kit. We've taken the Original Equipment black-painted component to ensure product quality and polished and chrome-plated it for a great look. Footpegs sold separately.

49322-04 **\$109.95**

Fits '04-'13 XL models. XL883, XL883L, XL883N, XL1200N, XL1200V and XL1200X models require separate purchase of four Screws P/N 4748.

50610-86T **\$29.95**

Fits '82-'03 XL models.

C. ADJUSTABLE PASSENGER FOOTPEG MOUNT KIT

Maximize your passenger's riding comfort. Proper foot position reduces the cramped or stretched-out feeling and relieves pressure on the knees and the tailbone. These Adjustable Mounts raise and lower the passenger footpeg to accommodate taller and shorter passengers. Easy to adjust with common tools, the mount adjusts through a 360° range (depending on model), allowing both fore and aft and up and down height adjustment. Kit includes left and right adjustable support assembly and all required mounting hardware. Footpegs sold separately.

50763-09 **\$149.95**

Fits models with H-D® male mount-style passenger footpeg supports (except Softail® models). Does not fit with Heel Raiser Footpeg Kit P/N 50178-09. Does not fit the rider position.



A. PASSENGER FOOTPEG MOUNT KIT – BLACK



B. PASSENGER FOOTPEG MOUNT KIT – CHROME (49322-04 SHOWN)

B. PASSENGER FOOTPEG MOUNT KIT – CHROME (50610-86T SHOWN)



C. ADJUSTABLE PASSENGER FOOTPEG MOUNT KIT

Notice: The prices appearing in this catalog are the manufacturer's suggested retail prices. Actual retail prices may vary.

NEW

SPORTSTER® 109

Gauges & Fuel Tank Trim

**D. COMBINATION DIGITAL SPEEDOMETER/ANALOG TACHOMETER – 4"****D. COMBINATION DIGITAL SPEEDOMETER/ANALOG TACHOMETER – 4"**

Maintain the clean view over the handlebar. This unique Combination Digital Speedometer/Analog Tachometer allows you to monitor engine speed, fuel level and gear position, without adding additional handlebar-mounted gauges. The digital speed reading can be easily toggled between MPH and km/h to simplify cross-border travel. The large, easy-to-read LCD odometer/tripmeter also displays fuel level, miles-to-empty, gear position and time. The gauge features push-button adjustable backlighting with over 600 color tone options, allowing the rider to adjust pointer, LCD and backlighting colors to match any paint scheme or viewing preference. The unit mounts in the stock dash opening and is a direct plug-in installation. Kit includes a data transfer cable to easily upload initial mileage at time of installation.

NOTE: As a result of different vehicle capabilities, the following exceptions apply: Gear position not available on '04-'07 models, Range function not available on '04-'06 XL models and '04-'08 Dyna® models, Fuel level function not available on '04-'06 XL models.

70900475 Spun Aluminum Dial, MPH/km/h **\$314.95**
U.S. models. Fits '14-later XL, '12-later Dyna and '11-later Softail® models equipped with 4" speedometer. XL models require separate purchase of Fuel Sensor Kit P/N 61200008 to make use of the fuel level and range function.

70900100C **\$314.95**
Non-U.S. models. Fits '14-later XL, '12-later FXDB and FXDWG, '11-later FXCW, FXS and FXSB models with 4" speedometer. XL models require separate purchase of Fuel Sensor Kit P/N 61200008 for fuel level and range function.

70900274 **\$309.974**
Worldwide models. Fits '04-'13 XL models (except XR, '04-'08 XL1200R and XL50), '04-'11 Dyna models with 4" speedometer and '08-'10 FXCW and FXCWC models. '07-'13 XL models require separate purchase of Fuel Sensor Kit P/N 61200008 to make use of the fuel level and range function. Does not fit XL883 models equipped with Screamin' Eagle® 1200cc Stage I Conversion Kit P/N 29784-07 and 30003-10.

Also available:**FUEL LEVEL SENSOR KIT**

61200008 **\$139.95**
Fits '07-later XL models equipped with Combination Digital Speedometer/Analog Tachometer P/N 70900274, 70900100C or 70900475.

E. SPORTSTER® FUEL GAUGE KIT*

Finally, keep an eye on your Sportster® model fuel level without watching how many miles you have traveled. In-tank sending unit employs capacitive sensing technology to accurately monitor the fuel level and relays the information to a handlebar-mounted LED indicator for at-a-glance viewing. The segmented LED display is set into a distinctive housing that replaces the brake master cylinder cover on the right hand control. The individual LED segments glow when the tank is full and count down one-by-one as the fuel level drops. Available in black or chrome finish to match your Original Equipment satin black or accessory chrome hand controls. Kit includes sending unit, LED master cylinder cover, wiring harness and all necessary installation hardware.

Fits '07-later XL and '08-'13 XR models. '14-later XL models require separate purchase of Electrical Connection Kit 72673-11.

75031-09 Black. **\$299.95**

75338-09 Chrome. **\$299.95**

*Some local regulations prohibit using colored lights during vehicle operation on public streets. May not conform to local lighting regulations.

F. FUEL TANK TRIM PANEL KIT – CHROME

Set your fuel tank apart from the rest with this mirror-chrome Fuel Tank Trim Panel. Fits around the stock fuel cap and is adhesive backed.

61653-04 **\$124.95**

Fits '04-later XL883C, XL1200L, XL1200C and '08-later XL1200R models. Also fits '04-later XL models equipped with a Sportster® Large Capacity Fuel Tank and Installation Kit P/N 62999-04 or 62999-07.

**E. SPORTSTER FUEL GAUGE KIT – CHROME****E. SPORTSTER FUEL GAUGE KIT – BLACK****F. FUEL TANK TRIM PANEL KIT – CHROME**

Notice: The prices appearing in this catalog are the manufacturer's suggested retail prices. Actual retail prices may vary.

SPORTSTER

110 SPORTSTER®

Chassis Trim – Front End

A. LOWER FORK SLIDERS – GLOSS BLACK

These gloss black coated sliders are the ultimate extension of your bike's "dark side" and make a perfect custom addition to your blacked-out ride. Manufactured to Original Equipment specifications, the durable black coating is a great match to other H-D® black components.

45500261 **\$429.95**
Fits '14-later XL883L and XL1200T models.

B. LOWER FORK SLIDERS – CHROME

Competitively priced, these chrome-plated Lower Fork Sliders give your bike upfront style. A perfect addition during the installation of Profile Low® Front suspension components. To ensure proper fitment and function, these sliders are manufactured from Original Equipment components. Form follows function, with polished triple chrome-plating and a stamped "Harley-Davidson" script logo for product identification.

45500258 **\$429.95**
Fits '14-later XL883L and XL1200T models.

45500226 **\$429.95**
Fits '11-later XL1200C models.

45500238 **\$429.95**
Fits '14-later XL1200V models.

46562-04A **\$429.95**
Fits '08-'13 XL1200L, XL1200V and '08-'10 XL models

(except XL883N, XL883R, XL1200N, XL1200R and XL1200X).

46492-00 **\$429.95**
Fits '00-'07 XL models (except XL883R, XL1200S and XL1200R) and '00-'03 FXD and '01-'03 FXDL models.

45275-98 **\$429.95**
Fits '88-'99 XL models and FXD Super Glide®, '87-later FXLR and '88-'99 FXR and FXRS. (Does not fit Sportster® Sport models.)

C. FRONT END KITS – CHROME*

The front forks on a Harley-Davidson® motorcycle set the tone for the bike and can lead the way to a full-bore custom statement. So start customizing by adding chrome where it will have the most noticeable impact on the overall look of the bike; your front end. This package includes components necessary to completely chrome the front forks and includes some or all of the following (Kit components vary depending on your model): Chrome Fork Sliders, Chrome Fork Axle Retainer Nut Kit, Chrome Fork Slider Drain Screw Kit, Chrome Front Wheel Spacers, Classic Chrome Front Axle Nut Cover Kit and Chrome Upper Fork Nut Covers.

46331-08A **\$529.95**
Fits '08-'11 XL1200L and '08-'10 XL883, XL883L, XL883C and XL1200C models.

46331-04 **\$529.95**
Fits '00-'07 XL models (except XL883R, XL1200R and XL1200S).

*Chrome Front End Package price does not include labor or supplies.



A. LOWER FORK SLIDERS – GLOSS BLACK



B. LOWER FORK SLIDERS – ('14-LATER XL1200V SHOWN)



B. LOWER FORK SLIDERS – ('14-LATER XL1200C SHOWN)



B. LOWER FORK SLIDERS – CHROME



C. FRONT END KITS – CHROME

Notice: The prices appearing in this catalog are the manufacturer's suggested retail prices. Actual retail prices may vary.



D. FRONT AXLE NUT COVERS – CHROME



D. FRONT AXLE NUT COVERS – GLOSS BLACK

NEW



E. "H-D MOTOR CO." LOGO FRONT AXLE NUT COVERS



F. BURST FRONT AXLE NUT COVERS

NEW



G. WILLIE G SKULL FRONT AXLE NUT COVERS



H. ALUMINATOR FRONT AXLE NUT COVERS



I. FRONT WHEEL SPACERS – CHROME TAPERED



I. FRONT WHEEL SPACERS – CHROME STRAIGHT

D. FRONT AXLE NUT COVERS

Cover the front axle in style. Available in chrome or gloss black finish, custom Axle Nut Covers look great with Original Equipment satin-finish fork sliders or add the finishing touch to a complete chrome or blacked-out front end. These Axle Cover Kits are easy to install and include all necessary mounting hardware. Sold in pairs.

Fits '02-'11 VRSC™ (except VRSCF, VRSCR and '12-later VRSCDX), '15-later XG, '08-later XL, '08-later Dyna®, '07-later Softail® (except Springer™, FXCW, FXCWC, FLSTNSE, FXSBSE, FXST-Aus and FXSTD) and '08-later Touring and Trike models.

44117-07A	Chrome – Die-cast.	\$27.95
43000026	Gloss Black – Die-cast.	\$27.95
44116-07A	Chrome – Billet.	\$42.95
43428-09	Gloss Black – Billet.	\$42.95

Fits '88-'07 XL, '91-'03 Dyna FXD, FXDX, FXDXT, FXDL, FXDS-CONV.; '93-'05 FXDWG, '84-'06 Softail (except Springer and FXSTD), '80-'99 Touring models. Also fits '88-'07 FXR and '87-later FLXR/FXRS-SP, FXWG models.

43899-86A	Chrome – Die-cast.	\$27.95
------------------	--------------------	----------------

E. "H-D MOTOR CO." LOGO FRONT AXLE NUT COVERS

Die-cast, chrome-plated covers feature the "Harley-Davidson Motor Co." logo in black. Includes Allen®-head set screws and wrench for easy installation.

44148-07A		\$29.95
------------------	--	----------------

Fits '02-'11 VRSC (except VRSCF, VRSCR and '12-later VRSCDX), '15-later XG, '08-later XL, '08-later Dyna, '07-later Softail (except Springer, FXCW, FXCWC, FXSB, FXSBSE, FXST-Aus, FXSTD and FLSTNSE) and '08-later Touring and Trike models.

F. BURST FRONT AXLE NUT COVERS

Finish your blacked-out forks in style. Rich black and prismatic machined surfaces provide the contrast and the race-track ridges and the inner spider design make a powerful visual statement. Easy to install kit includes mounting hardware.

43000031		\$69.95
-----------------	--	----------------

Fits '02-'11 VRSC (except VRSCF, VRSCR and '12-later VRSCDX), '15-later XG, '08-later XL, '08-later Dyna, '07-later Softail (except Springer, FXCW, FXCWC, FXSB, FXSBSE, FXSTD and FLSTNSE) and '08-later Touring models.

G. WILLIE G SKULL FRONT AXLE NUT COVERS

Add a little attitude to your ride. Styled to complement Harley-Davidson® Skull accessory items, the menacing raised skull with black-filled eyes leaps from a field of chrome. The surrounding "Harley-Davidson Motorcycles" script is the perfect finishing touch. The Axle Nut Covers are easy to install and include all necessary mounting hardware. Sold in pairs.

43163-08A		\$34.95
------------------	--	----------------

Fits '02-'11 VRSC (except VRSCF, VRSCR and '12-later VRSCDX), '15-later XG, '88-later XL, '91-later Dyna, '84-later Softail (except Springer, FXCW, FXCWC, FXSB, FXSBSE, FXSTD and FLSTNSE), '99-later Touring and '08-later Trike models.

H. ALUMINATOR® FRONT AXLE NUT COVERS

Chrome-plated billet aluminum axle covers feature a classic Bar & Shield logo insert. Includes all necessary mounting hardware for easy installation.

43907-94		\$42.95
-----------------	--	----------------

Fits '88-'07 XL, '91-'03 Dyna FXD, FXDX, FXDXT, FXDL, FXDS-CONV.; '93-'05 FXDWG, '84-'06 Softail (except Springer and FXSTD), '80-'99 Touring models. Also fits '88-'07 FXR and '87-later FLXR/FXRS-SP, FXWG models.

I. FRONT WHEEL SPACERS – CHROME

Complete your total front end with these highly polished chrome-plated wheel spacers. Manufactured to the Original Equipment tolerances, they deliver exact fitment and custom shine.

41370-08	Tapered.	\$29.95
-----------------	----------	----------------

Fits '08-'13 XL models (except XL1200X, XL883L and '11-'13 XL1200C).

41616-02	Straight.	\$29.95
-----------------	-----------	----------------

Fits '00-'07 XL models and '00-'03 FXD, FXDL, FXDX, FXDXT and FXDS-CONV. models.

112 SPORTSTER®

Chassis Trim – Front End

A. FORK AXLE RETAINER NUT KIT – CHROME

It's the details that count. Complete the chrome transformation by adding this finishing touch to your chrome fork sliders. This Axle Retainer Nut Kit includes the stylish chrome-plated nuts and chrome lockwashers necessary to replace the stock hardware.

45802-03 **\$8.95**

Fits '88-later XL models, '93-'05 FXD, FXDL, FXDS-CONV., FXDX, FXDX-T models and '88-'94 FXR, FXRS, FXRS-SP, FXRS-CONV., FXLR, FXRT models.

Shown with:

FORK SLIDER DRAIN SCREW KIT – CHROME

This Fork Slider Drain Screw Kit includes two chrome-plated drain screws and the seals required to replace the stock hardware.

45815-03 **\$3.95**

Fits '73-'13 XL models (except XL Sport, XL883L, XL1200X and '11-later XL1200C), '78-'86 FX models, '94-'05 Dyna® FXD/DL/DS-CONV., '99-'00 FXR2/3/4 models and '00-'07 FXSTD models.



A. FORK AXLE RETAINER NUT KIT – CHROME (SHOWN WITH CHROME DRAIN SCREW KIT)



B. SCREAMIN' EAGLE FORK BRACE – CHROME

B. SCREAMIN' EAGLE® FORK BRACE – CHROME

This Chrome Fork Brace is machined from billet aluminum, then polished and chrome-plated. Easy to install, this brace offers increased torsional rigidity.

46192-99A **\$219.95**

Fits '87-later XL (except XL883N, XL883L, XL1200N, XL1200T, XL1200X, '11-later XL1200C), '91-'05 Dyna (except FXDWG) and FXR models (except FXRT) with 39mm front forks. (Will not fit with Chrome Fork Sliders).

C. UPPER FORK STEM COVERS – CHROME

Highlighted with a unique Bar & Shield logo, these polished triple chrome-plated covers add an additional clean-looking appearance to your upper fork. Kit comes complete with three covers, mounting hardware and wrench for easy on-the-spot installation.

46129-98B **\$59.95**

Fits '86-later FLSTC, '90-later FLS, FLSTF, '95-'05 FXD, '93-'05 FXDL, '94-'05 FXDS-CONV. and '88-'13 XL models (except XL Custom and XL1200S models.)



C. UPPER FORK STEM COVERS – CHROME

D. CLASSIC CHROME STEERING STEM BOLT COVER KIT

For a finished appearance of the upper fork clamp on all models with 39mm forks.

48329-90A **\$39.95**

Fits XL, '91-'05 Dyna and FXR models with 39mm forks. (Does not fit FXDWG.)



D. CLASSIC CHROME STEERING STEM BOLT COVER KIT

E. HEADLAMP BRACKET – CHROME

Replace stock aluminum with this chrome-plated visor eyebrow, one part of a perfectly chromed front end.

69709-00A **\$69.95**

Fits '92-later XL models (except XL883C, XL1200C, XL1200V, XL1200T, XL1200X and XL Custom) and '93-'05 Dyna models (except FXDWG).



E. HEADLAMP BRACKET – CHROME

F. HEADLIGHT COVER – CHROME

Cover the Original Equipment aluminum headlamp eyebrow with this polished and chrome-plated cover.

67871-85TA With Cutout. **\$20.95**

Fits '60-later XL models (except '96-later XL Custom, XL1200V and XL1200X), '91-'05 FXDL, '71-'13 FX and FXR models (except FXWG, FXSB, FXSBSE and FXST).

67884-90TA Without Cutout. **\$20.95**

Fits XL models (except '96-later XL Custom, XL1200V, XL1200X), FXR models with indicator lights mounted in speedometer bracket and '91-'05 Dyna models (except FXDWG).



F. HEADLIGHT COVER – CHROME (WITH CUTOUT)



F. HEADLIGHT COVER – CHROME (WITHOUT CUTOUT)

Notice: The prices appearing in this catalog are the manufacturer's suggested retail prices. Actual retail prices may vary.



NEW

G. BRAKE CALIPER KIT – RED
(41300134 SHOWN)

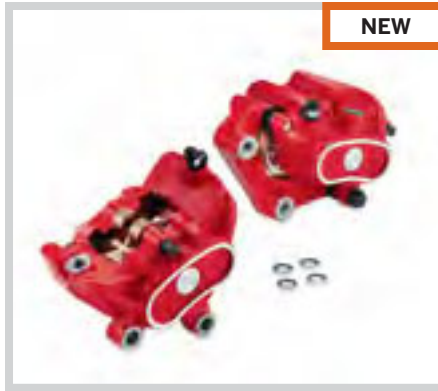

NEW

G. BRAKE CALIPER KIT – RED
(41300134 SHOWN)

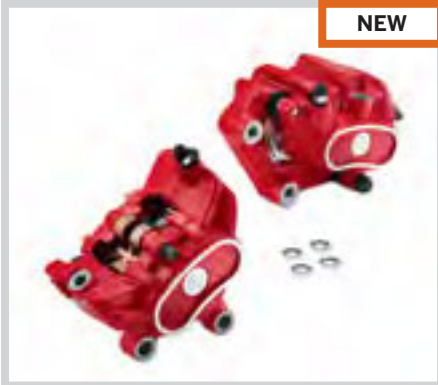

NEW

G. BRAKE CALIPER KIT – RED
(41300131 SHOWN)



NEW

G. BRAKE CALIPER KIT – RED
(41300142 SHOWN)



NEW

G. BRAKE CALIPER KIT – RED
(41300126 SHOWN)



NEW

G. BRAKE CALIPER KIT – RED
(41300120 SHOWN)



H. BRAKE CALIPER KIT – CHROME



I. BRAKE CALIPER INSERTS

G. BRAKE CALIPER KIT – RED

Dress your bike in the latest high-performance look. Brilliant red calipers make a powerful visual statement and set your bike apart from the ordinary. Manufactured from Original Equipment components for proven performance, these calipers will add a stylish touch to the stock bike or add the perfect finish to a complete custom equipped with chrome or blacked-out wheels, rotors and fork sliders.

41300134 Front & Rear Kit. **\$399.95**

Fits '14-later XL models with single disc front brakes. Kit includes one front and one rear caliper. Includes brake pads.

41300131 Front & Rear Kit. **\$399.95**

Fits '11-'13 XL models equipped with single disc front brakes. The kit includes one front and one rear caliper. Includes brake pads.

41300142 Front & Rear Kit. **\$399.95**

Fits '08-'10 XL models equipped with single disc front brakes. The kit includes one front and one rear caliper. Includes brake pads.

41300126 Front – Single Disc. **\$249.95**
Fits '00-'03 XL, '00-'07 Dyna® and '00-'07 Softail® models with single disc front brakes. Brake pads sold separately.

41300120 Front – Dual Disc. **\$399.95**

Fits '02-'05 VRSC, '00-'03 XL, '00-'07 Dyna and '00-'07 Touring models with dual disc front brakes. Brake pads sold separately.

H. BRAKE CALIPER KIT – CHROME

Add the shine of chrome to your front end with this highly-polished Chrome Front Brake Caliper Kit. Manufactured from Original Equipment components for proven performance, these calipers are a great addition to the stock front end or they add the finishing touch to a complete custom with chrome wheels, rotors and chrome fork sliders. (Brake pads and pad pins not included.)

44395-00A Front – Single Disc. **\$389.95**

Fits '00-'03 XL and '00-'07 Dyna and Softail (except Springer™) models equipped with single disc front brakes.

44392-00A Front – Dual Disc. **\$799.95**

Fits '00-'03 XL, '02-'05 VRSC™ and '00-'07 Dyna, Softail and Touring models equipped with dual disc front brakes.

I. BRAKE CALIPER INSERTS

Easy-to-install inserts add a finishing touch to the front and rear brake calipers. Select a style that follows your custom direction. Self-adhesive backing.

Fits front and rear calipers on '04-'13 XL models.

1. 42070-07 Willie G Skull Collection. **\$16.95**

2. 44621-04 "H-D Motor Co." Logo Collection. **\$16.95**

3. 44622-04 "Live to Ride" Logo Collection. **\$16.95**

4. 44623-04 Flames Collection. **\$16.95**

114 SPORTSTER®

Chassis Trim – Rear End

A. UPPER BELT GUARD – CHROME

Attract attention to your Sportster® motorcycle by replacing the black Original Equipment component, providing exceptional chrome-plated detail to the rear drive system. Easy to clean and simple to install.

60402-04 Fits '04-later XL models. **\$89.95**

B. BUCKSHOT UPPER BELT GUARD – GLOSS BLACK

Add the “blacked-out” look of the Nightster® motorcycle to your Sportster model. The perforated “Buckshot” design visually lightens the belt guard and adds a raw, purposeful edge to the bike’s profile.

60379-09 **\$89.95**
Fits '04-later XL models.

C. BUCKSHOT UPPER BELT GUARD – BRUSHED NICKEL

This perforated “Buckshot” belt guard design visually lightens the bike’s profile and adds a raw, mechanical edge to the overall look. Available in brushed nickel “Silencer” finish, this easy-to-install guard provides a stripped-down open look while protecting the belt from road debris.

60300045 Fits '04-later XL models. **\$89.95**

D. LOWER BELT GUARD – CHROME

This handsome steel cover is polished, chrome-plated and designed to replace the Original Equipment black plastic cover. Easy to install, this guard looks great when combined with a Harley-Davidson® Chrome Upper Belt Guard.

57100226 Fits '04-later XL models. **\$99.95**

E. SWINGARM – CHROME

The ultimate chrome accessory, polished to the highest standard using bright plating to match Original Equipment chrome. Affordable and convenient, with no troublesome exchanges necessary. Factory specifications guarantee exact fitment, unparalleled quality and an affordable price. Stamped with the Harley-Davidson Bar & Shield logo.

48434-05A **\$249.95**
Fits '05-later XL models (except XL1200T).



A. UPPER BELT GUARD – CHROME
(SHOWN WITH CHROME LOWER BELT GUARD AND SWINGARM)



B. BUCKSHOT UPPER BELT GUARD – GLOSS BLACK



C. BUCKSHOT UPPER BELT GUARD – BRUSHED NICKEL



D. LOWER BELT GUARD – CHROME



E. SWINGARM – CHROME

Notice: The prices appearing in this catalog are the manufacturer's suggested retail prices. Actual retail prices may vary.



F. SHOCK BOLT COVERS – CHROME



F. SHOCK BOLT COVERS – GLOSS BLACK



G. BAR & SHIELD LOGO REAR AXLE COVERS – CHROME



G. BAR & SHIELD LOGO REAR AXLE COVERS – GLOSS BLACK



H. SWINGARM PIVOT BOLT COVERS – CHROME



H. SWINGARM PIVOT BOLT COVERS – GLOSS BLACK



I. SWINGARM PIVOT BOLT COVERS – WILLIE G SKULL COLLECTION



J. REAR BRAKE RESERVOIR COVER

F. SHOCK BOLT COVERS

It's the details that complete the look of your bike. These Shock Bolt Covers are designed to hide the upper shock mounting hardware and provide a custom look to the rear of your bike. Easy-to-install, the kit includes left and right bolt covers and all required mounting hardware.

Fits '04-later XL and '06-later Dyna® models (except FLD, FXDF and FXDL).

54000016	Chrome.	\$39.95
54000017	Gloss Black.	\$39.95

G. BAR & SHIELD LOGO REAR AXLE COVERS

Die-cast cover conceals the side of the swingarm and axle. Unique styling features an embossed Bar & Shield logo. Easy to install without removing the rear wheel. Kit includes all necessary mounting hardware.

Fits '05-later XL883C, XL883L, XL883N, XL1200C, XL1200L, XL1200N, XL1200V and XL1200X models. Also fits '05-later XL models equipped with Low Rear Suspension Kit P/N 54731-04, 54733-04 or 54750-05. (Will not fit models equipped with saddlebags or Chrome Billet Shock Hardware Kit P/N 54337-05.)

46399-05A	Chrome.	\$54.95
43013-09A	Gloss Black.	\$54.95

H. SWINGARM PIVOT BOLT COVERS

Cover the swingarm pivot bolt in classic style. Available in your choice of chrome or gloss black finish, these easy-to-install kits include left and right die-cast pivot bolt covers and necessary mounting hardware.

Fits '04-'13 XL models.

43580-04	Chrome.	\$29.95
47625-09	Gloss Black.	\$31.95

I. SWINGARM PIVOT BOLT COVERS – WILLIE G SKULL COLLECTION

Add a little attitude to your ride. Styled to complement Harley-Davidson® Skull accessory items, the menacing raised skull with black-filled eyes leaps from a field of chrome. The surrounding "Harley-Davidson Motorcycles" script is the perfect finishing touch. This easy-to-install kit includes left and right pivot bolt covers and necessary mounting hardware.

42072-07	Fits '04-'13 XL models.	\$31.95
-----------------	-------------------------	----------------

J. REAR BRAKE RESERVOIR COVER

Dress the remote brake fluid reservoir with a new chrome skin. Kit includes chrome top cover with Bar & Shield medallion, reservoir side cover, chrome hardware and a Torx® wrench for easy installation.

45424-08	Fits '07-'13 XL models.	\$35.95
45762-04	Fits '04-'06 XL models.	\$35.95

Notice: The prices appearing in this catalog are the manufacturer's suggested retail prices. Actual retail prices may vary.

116 SPORTSTER®

Chassis Trim – Rear End

A. "BIG SPOKE" SPROCKET COVER – CHROME

Muscle rules. Big, beefy spokes define the distinctive hot rod styling and the small trapezoidal openings are reminiscent of Detroit's street performance wheels of the late '60s. The chrome-plated steel cover disguises the Original Equipment sprocket and complements both stock and custom wheels. Easy to install, this cover provides the look of a billet sprocket at a fraction of the cost.

40124-10 Fits '04-later XL and XR models. **\$49.95**



A. "BIG SPOKE" SPROCKET COVER – CHROME

B. SPROCKET COVER – CHROME

The five-spoke Sprocket Cover matches the styling of the Original Equipment sprocket, providing the appearance of a chrome sprocket at a fraction of the cost. The raised ribs mimic the look of a billet sprocket. Easy to install, the cover looks great with Chrome Upper and Lower Belt Guards.

91746-03 Fits '04-later XL and XR models. **\$49.95**



B. SPROCKET COVER – CHROME

C. SPROCKET COVER WITH HOLES – CHROME

This handsome steel cover is polished and chrome-plated. Easy to install and looks great when combined with Harley-Davidson® Chrome Belt Guard. Chrome Hardware Kit P/N 94708-98 completes the look.

40279-91A Fits '91-'03 XL models. **\$49.95**



C. SPROCKET COVER WITH HOLES – CHROME

D. SPROCKET HARDWARE – CHROME HEX HEAD

This kit includes highly-polished, chrome-plated, grade 8 hex-head screws with chrome-plated washers, providing an extra custom accent. The perfect addition to the chrome sprocket. Made from the same Original Equipment bolts to ensure product integrity. Also works with chrome belt sprocket covers and Original Equipment sprockets.

94708-98 **\$29.95**
Fits '93-'99 Softail®, '93-'99 Dyna®, '91-later XL models.



D. SPROCKET HARDWARE – CHROME HEX HEAD

E. REAR SPROCKET BOLT COVER KIT

These chrome-plated covers with internal spring clips hide the Original Equipment sprocket bolts for a clean, custom look. Set of 5 covers.

43876-04 **\$38.95**
Fits '93-later Softail, '99-later Touring and '04-later XL models with Original Equipment 7/16" hex head sprocket mounting bolts (5/8" hex across the flats).



E. REAR SPROCKET BOLT COVER KIT

F. FRONT ENGINE MOUNT BRACKET

A must-have for any chrome connoisseur; this chrome-plated Front Engine Mount Bracket will set your custom apart from the rest. The chrome bracket is machined from premium 6061-T6 aluminum and is a direct bolt-on replacement for the Original Equipment upper bracket. Can be used with the stock stabilizer link or dressed up with the optional chrome Front Engine Mount Stabilizer Link P/N 16400020. Kit includes chrome mounting hardware.

16400022 **\$129.95**
Fits '04-later XL models.



G. FRONT ENGINE MOUNT STABILIZER LINK

Add a custom style to the front end with this brilliant chrome-plated Engine Mount Stabilizer Link. This custom heim joint assembly is designed to link the engine to the engine mount bracket and can be used to replace the Original Equipment upper or lower front tie link. For a complete transformation, install two Stabilizer Links and the complementing chrome Billet Front Engine Mount Bracket P/N 16400022. Kit includes one stabilizer link and chrome mounting hardware.

16400020 **\$49.95**
Fits '04-later XL and XR models.



F. FRONT ENGINE MOUNT BRACKET



G. FRONT ENGINE MOUNT STABILIZER LINK

Notice: The prices appearing in this catalog are the manufacturer's suggested retail prices. Actual retail prices may vary.



H. CHROME ENGINE KIT – SPORTSTER

H. CHROME ENGINE KIT – SPORTSTER®

Upgrade your motor with brilliant chrome components. Kit includes chrome gear cover, transmission sprocket cover, primary chain inspection cover, derby cover, inner and outer rocker covers and all gaskets.

16295-07A \$949.95

Fits '07-later XL models. Stock on '07-later XL1200C, XL1200L, XL1200T, XL1200V and XL 50th Anniversary models.

I. SPORTSTER ENGINE COVERS – CHROME**1. Gearcase Cover**

25213-04 Fits '04-later XL models. \$439.95

25213-96B Fits '91-'03 XL models. \$439.95

2. Transmission Sprocket Cover

34932-06 Fits '04-later XL models. \$129.95

34932-94 Fits '91-'03 XL models. \$139.95

3. Rocker Box Lower Housing (each)

17537-07A Fits '07-later XL models. \$114.95

17537-96C Fits '86-'06 XL models. \$114.95

4. Rocker Box Cover (each)

17551-04 Fits '04-later XL models. \$98.95

17551-96 Fits '86-'03 XL models. \$98.95

5. Rocker Cover Spacer (each)

17538-96 Fits '91-'03 XL models. \$145.95

6. Primary Cover

25460-06 Fits '06-later XL models. \$349.95

25460-04 Fits '04-'05 XL models. \$349.95

25460-94 Fits '94-'03 XL models. \$349.95

7. Primary Chain Inspection Cover

34761-04A Fits '04-later XL models. \$24.95

34761-94 Fits '94-'03 XL models. \$39.95

8. Derby Cover

34760-04 Fits '04-later XL models. \$69.95

34760-94 Fits '94-'03 XL models. \$99.95

9. Shift Lever

34606-90T Fits '91-'03 XL models. \$62.50

J. SPORTSTER ENGINE COVERS – WRINKLE BLACK**1. Gearcase Cover**

25486-05 Fits '04-later XL models. \$369.95

2. Transmission Sprocket Cover

34943-05 Fits '04-later XL models. \$81.95

3. Rocker Box Lower Housing (each)

17645-07A Fits '07-later XL models. \$89.95

17645-06A Fits '86-'06 XL models. \$89.95

4. Rocker Box Cover (each)

17655-05 Fits '04-later XL models. \$74.95

5. Primary Cover

25307-06 Fits '06-later XL models. \$269.95

6. Primary Chain Inspection Cover

34794-05A Fits '04-later XL models. \$19.95

7. Derby Cover

34790-05 Fits '04-later XL models. \$39.95

NOTE: Removing and installing engine covers may require purchase of new gaskets. See dealer for information.

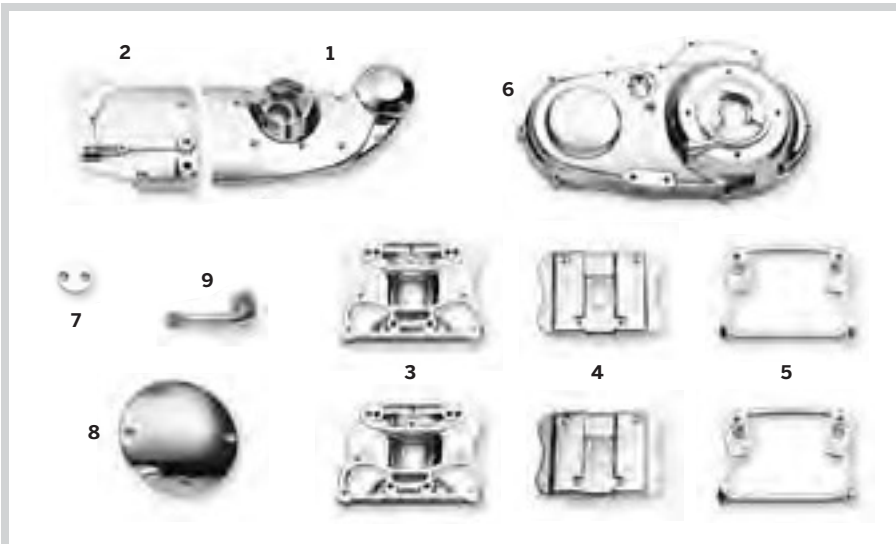

I. SPORTSTER ENGINE COVERS – CHROME ('86-'03 MODELS SHOWN)



J. SPORTSTER ENGINE COVERS – WRINKLE BLACK

Notice: The prices appearing in this catalog are the manufacturer's suggested retail prices. Actual retail prices may vary.

118 SPORTSTER®

Engine & Transmission Trim

A. PRIMARY COVER TRIM – CHROME

Dress your engine in chrome. This precision-stamped steel cover wraps the Original Equipment aluminum primary cover in brilliant chrome, at a fraction of the cost of chrome replacement components. Kit includes chrome-plated installation hardware.

25233-04 **\$124.95**

Fits '04-later XL and XR models. (Does not fit with Primary and Cylinder Base Cover Trim P/N 25700196 or 25700194.)



A. PRIMARY COVER TRIM – CHROME



A. PRIMARY COVER TRIM – CHROME

B. ENGINE SPROCKET COVER TRIM – CHROME

This chrome-plated steel skin fits over the Original Equipment aluminum sprocket cover, giving the appearance of a chrome engine at a fraction of the cost. When combined with the available Chrome Gearcase Cover Trim, you get a complete chrome look from front to rear. Kit includes chrome-plated mounting hardware.

34944-04 Fits '04-later XL models. **\$44.95**



B. ENGINE SPROCKET COVER TRIM – CHROME



C. GEARCASE COVER TRIM – CHROME

C. GEARCASE COVER TRIM – CHROME

Rather than spending the time and money on chrome exchanges, this brilliant chrome cover fits over the Original Equipment aluminum gearcase like a second skin. This steel cover is shaped to mirror the contour for a perfect fit and when matched with Chrome Engine Sprocket Cover Trim, is a simple way to add instant style. Kit includes chrome-plated mounting hardware.

25231-04 Fits '04-later XL models. **\$89.95**

D. PRIMARY AND CYLINDER BASE COVER TRIM

Get the look of a custom outer primary and engine crankcase with one custom cover. These ribbed covers are designed to wrap the top surface of the outer primary cover and provide a beefy finished look to the engine cases. Easy to install, the primary cover is secured with the outer primary hardware. To complete the look, the kit includes a matching cover that conceals the front and rear cylinder bases to provide a unified look to the left side of the engine. Kit includes required mounting hardware.

Fits '04-later XL models. Does not fit with Primary Cover Trim P/N 25233-04.

25700196 Chrome. **\$119.95**

25700194 Wrinkle Black. **\$119.95**



D. PRIMARY AND CYLINDER BASE COVER TRIM – CHROME



D. PRIMARY AND CYLINDER BASE COVER TRIM – WRINKLE BLACK



Notice: The prices appearing in this catalog are the manufacturer's suggested retail prices. Actual retail prices may vary.

SPORTSTER® 119

Engine & Transmission Trim



E. CYLINDER BASE COVER WITH BAR & SHIELD LOGO



F. CYLINDER BASE COVER

E. CYLINDER BASE COVER WITH BAR & SHIELD LOGO

Add a finished chrome look to the left side of the Sportster® engine. The mirror-chrome surface complements both silver and black engine finishes and the deep embossed Bar & Shield logo provides a custom touch. Easy to install, the complete kit includes all necessary mounting hardware.

32729-07 Fits '04-later XL models. **\$59.95**

F. CYLINDER BASE COVER

Adds chrome highlights to the left side of a Sportster model. Installs in minutes.

32732-98 Fits '91-'03 XL models. **\$59.95**

G. STARTER COVER

Cover and conceal the starter motor and the area behind the rear cylinder with a splash of style. This shapely ribbed and slotted cover conceals the starter motor and starter solenoid for a clean, custom look. Kit includes all required mounting hardware.

Fits '04-later XL models.

34800008 Chrome. **\$64.95**

34800007 Wrinkle Black. **\$64.95**

H. TAPPET BLOCK ACCENT

Shaped to surround and fill the gap between the tappet blocks, this unique ribbed cover adds a splash of style to the profile of your engine. The easy-to-install cover is the perfect finishing touch to the bike's profile. Kit includes all necessary mounting hardware.

Fits '04-later XL models.

25700197 Chrome. **\$64.95**

25700195 Wrinkle Black. **\$64.95**

I. TAPPET BLOCK COVER KIT

This one-piece chrome-plated cover is designed to conceal the lifter blocks and hardware for a clean, custom look. Featuring an embossed Bar & Shield logo, this complete kit covers the lifter block area and extends the chrome look from the gearcase cover to the pushrod tubes. All exposed hardware is chrome-plated and the kit includes all necessary mounting hardware.

18241-04 Fits '04-later XL models. **\$64.95**

J. STARTER SOLENOID COVER KIT – CHROME

Add chrome to an often overlooked area with this cover, featuring the same high-quality, bright finish used on most of our accessories.

31783-00 **\$21.95**

Fits '94-later models (except '02-later VRSC™ and XG).



G. STARTER COVER – CHROME



G. STARTER COVER – WRINKLE BLACK



H. TAPPET BLOCK ACCENT – CHROME



H. TAPPET BLOCK ACCENT – WRINKLE BLACK



I. TAPPET BLOCK COVER KIT



J. STARTER SOLENOID COVER KIT – CHROME

SPORTSTER

Notice: The prices appearing in this catalog are the manufacturer's suggested retail prices. Actual retail prices may vary.

120 SPORTSTER®

Engine & Transmission Trim

A. NUMBER ONE SKULL COLLECTION

The sinister Harley-Davidson #1 Skull logo dresses for a night on the town. This complete die-cast aluminum collection has been polished and chrome-plated to a brilliant shine, then finished with a contrasting black-filled Dark Custom™ Skull logo. The black-filled race track stripe and recessed hardware pockets provide added depth and dimension. Includes chrome-plated mounting hardware.

1. 25333-10 Derby Cover. **\$74.95**
Fits '04-later XL models.

2. 32520-10 Timer Cover. **\$28.95**
Fits '04-later XL, XR and earlier models with horizontal holes on timer cover.

3. 27957-10 Air Cleaner Trim. **\$45.95**
Fits '04-later XL models (except XL1200V) equipped with Original Equipment oval air cleaner cover.



A. NUMBER ONE SKULL COLLECTION

B. DARK CUSTOM™ LOGO COLLECTION

The famous Harley-Davidson #1 logo with a sinister twist. Machined from billet aluminum, these covers feature domed surfaces that are polished and black anodized to a rich satin sheen, and then re-machined to expose the raw aluminum. The resulting high-contrast design complements both polished and painted engine finishes.

1. 25563-09 Derby Cover. **\$144.95**
Fits '04-later XL models.

2. 32414-09 Timer Cover. **\$64.95**
Fits '99-later Twin Cam-equipped models.

3. 61300055 Air Cleaner Trim. **\$114.95**
Fits '04-later XL models (except XL1200V) with Original Equipment oval air cleaner cover.



B. DARK CUSTOM LOGO COLLECTION

C. SKULL & CHAIN COLLECTION – CHROME

Links to the dark side. This collection stands out in a crowd, with a contrasting 3-D chain that rims the surface and surrounds the distinctive raised Willie G Skull.

1. 25700257 Derby Cover. **\$89.95**
Fits '04-later XL and XR models. Includes chrome-plated stainless steel hardware.

2. 25600027 Timer Cover. **\$41.95**
Fits '04-later XL, XR and earlier models with horizontal holes on timer cover. Includes chrome-plated stainless steel hardware.



C. SKULL & CHAIN COLLECTION – CHROME

D. SKULL & CHAIN COLLECTION – SMOKEY CHROME

The sinister smokey chrome finish is the ideal complement to the blacked-out ride, and the contrasting 3-D chain rims the surface and surrounds the distinctive Willie G Skull with black-filled eyes.

1. 25700255 Derby Cover – Skull. **\$89.95**
Fits '04-later XL and XR models. Includes chrome-plated stainless steel hardware.

2. 25600025 Timer Cover – Skull. **\$41.95**
Fits '04-later XL, XR and earlier models with horizontal holes on timer cover. Includes chrome-plated stainless steel hardware.



D. SKULL & CHAIN COLLECTION – SMOKEY CHROME

Notice: The prices appearing in this catalog are the manufacturer's suggested retail prices. Actual retail prices may vary.



E. WILLIE G SKULL COLLECTION

**E. WILLIE G SKULL COLLECTION**

Add a little attitude to your ride. Styled to complement Harley-Davidson® Skull accessory items, the menacing raised skull with black-filled eyes leaps from a field of chrome. The surrounding "Harley-Davidson Motorcycles" script is the perfect finishing touch. This complete collection of engine covers dresses your bike for a true custom look.

1. 25440-04A Derby Cover. **\$64.95**
Fits '04-later XL and XR models. Includes chrome-plated stainless steel mounting hardware.

2. 32972-04A Timer Cover. **\$28.95**
Fits '04-later XL, XR and earlier models with horizontal holes on timer cover. Includes chrome-plated stainless steel mounting hardware.

3. 29416-04 Air Cleaner Trim. **\$43.95**
Fits '04-later XL models (except XL1200V) equipped with Original Equipment oval air cleaner cover.



F. DIAMOND ICE COLLECTION

**F. DIAMOND ICE COLLECTION**

Add a touch of "bling" to your ride. Set against mirror-polished chrome, these crystal clear rhinestones add a brilliant flash, and dance in the direct sunlight. This complete line of engine trim is easy to install, and adds a bold and bright rhinestone-encrusted Bar & Shield logo to the profile of your bike. Kits include chrome-plated mounting hardware.

1. 25341-10 Derby Cover. **\$89.95**
Fits '04-later XL and XR models.

2. 32541-10 Timer Cover. **\$49.95**
Fits '04-later XL, XR and earlier models with horizontal holes on timer cover.

3. 27961-10 Air Cleaner Trim. **\$59.95**
Fits '04-later XL models (except XL1200V) equipped with Original Equipment oval air cleaner cover.

G. THE FLAMES COLLECTION – GOLD & CHROME

Ever since they began emerging on gas tanks a few decades ago, flames have been a symbol of custom styling. Now, Harley-Davidson continues the tradition with the Flames Collection.

1. 25125-04A Derby Cover. **\$69.95**
Fits '04-later XL and XR models. Includes chrome-plated stainless steel mounting hardware.

25400-98 Derby Cover (not shown). **\$64.95**
Fits '94-'03 Sportster models.

2. 32571-98A Timer Cover. **\$28.95**
Fits '04-later XL, XR and earlier models with horizontal holes on timer cover. Includes chrome-plated stainless steel mounting hardware.

3. 29824-04 Air Cleaner Trim. **\$43.95**
Fits '04-later XL models (except XL1200V) equipped with Original Equipment oval air cleaner.



G. THE FLAMES COLLECTION – GOLD & CHROME

**H. HARLEY-DAVIDSON® MOTOR CO. COLLECTION**

This collection personifies Harley style. It had better, because we put our name on it – The Harley-Davidson Motor Co. Collection.

1. 25130-04A Derby Cover. **\$46.95**
Fits '04-later XL and XR models. Includes chrome-plated stainless steel mounting hardware.

25332-98 Derby Cover. (not shown) **\$46.95**
Fits '94-'03 Sportster models.

2. 32668-98A Timer Cover. **\$25.95**
Fits '04-later XL, XR and earlier models with horizontal holes on timer cover. Includes chrome-plated stainless steel mounting hardware.



H. HARLEY-DAVIDSON MOTOR CO. COLLECTION



122 SPORTSTER®

Engine & Transmission Trim

A. THE HARLEY-DAVIDSON® “LIVE TO RIDE” COLLECTION – GOLD

“Live To Ride, Ride to Live.” It has become the motto of the Harley-Davidson nation, accompanying riders over millions of miles of travel. This collection is a tribute to that way of life.

1. 25127-04A Derby Cover. **\$69.95**
Fits '04-later XL and XR models. Includes chrome-plated stainless steel mounting hardware.

25398-95T Derby Cover. (not shown) **\$64.95**
Fits '94-'03 Sportster models.

2. 32585-90T Timer Cover. **\$37.95**
Fits models with vertical mounting holes.

32581-90TB Timer Cover. (not shown) **\$37.95**
Fits '04-later XL, XR and earlier models with horizontal holes on timer cover. Includes chrome-plated stainless steel mounting hardware.

3. 29823-04 Air Cleaner Trim. **\$43.95**
Fits '04-later XL models (except XL1200V) equipped with Original Equipment oval air cleaner.

4. 29405-90T Oval Air Cleaner Trim. **\$49.95**
Fits '66-'78 and '83-'03 XL models, '67-early '78 FL and '71-early '78 FX models.

B. CLASSIC CHROME COVERS

From the design philosophy of less is more, we bring you this collection of basic chrome accessories, which provides a clean, custom look that is guaranteed to turn heads.

1. 34760-04 Derby Cover. **\$69.95**
Fits '04-later XL models.

2. 32584-88TA Timer Cover. **\$25.95**
Fits '04-later XL, XR and earlier models with horizontal holes on timer cover. Includes chrome-plated stainless steel mounting hardware.

3. 34761-94 Chain Inspection Cover. **\$39.95**
Fits '94-'03 XL models.

34761-04A Chain Inspection Cover. (not shown) **\$24.95**
Fits '04-later XL models.

C. BLACK DERBY COVERS

Available in wrinkle black, this simple Derby Cover adds a finishing touch to your blacked-out engine.

34790-05 Wrinkle Black. **\$39.95**
Fits '04-later XL models.

D. CLASSIC COVERS KIT

Customize your bike down to the last detail. These hardware Cover Kits include the chrome-plated ABS caps and plugs in the sizes and styles required to dress the viewable hardware on the motorcycle. Classic Covers are available as complete Bike Kits with the covers for both engine and chassis hardware, or as engine-only kits to dress the Twin Cam or XL engine. The kits are easy to install, with no tools required.

94946-07 Bike Kit. **\$194.95**
Fits '04-later XL models.

94944-07 Engine Kit. **\$144.95**
Fits '04-later XL models.



A. THE HARLEY-DAVIDSON “LIVE TO RIDE” COLLECTION – GOLD

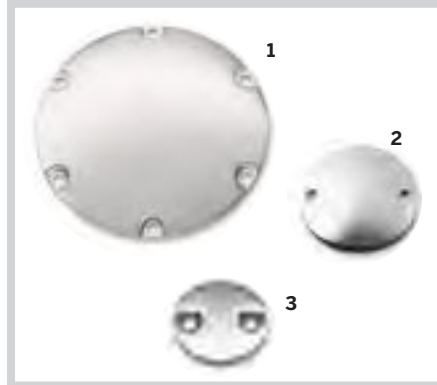

B. CLASSIC CHROME COVERS



C. BLACK DERBY COVERS



D. CLASSIC COVERS KIT



D. CLASSIC COVERS KIT – BIKE



D. CLASSIC COVERS KIT – ENGINE

Notice: The prices appearing in this catalog are the manufacturer's suggested retail prices. Actual retail prices may vary.

SPORTSTER® 123

Engine & Transmission Trim



E. FINNED HEADBOLT BRIDGE – BLACK HIGHLIGHTED



E. FINNED HEADBOLT BRIDGE – SOLID BLACK

E. FINNED HEADBOLT BRIDGE

This exclusive aluminum Finned Headbolt Bridge covers both headbolts and the spark plug, filling out your cylinder fins all the way to the rocker box. Featuring an engraved Bar & Shield emblem, the bridge is easy to install with unique headbolt mounts. All necessary mounting hardware included. Sold in pairs.

Fits '04-later XL models.

44296-04	Black Highlighted.	\$51.95
61400176	Solid Black.	\$51.95

F. HEADBOLT BRIDGE – CHROME

This exclusive Headbolt Bridge covers both the headbolts and spark plug with a splash of chrome and an engraved Bar & Shield emblem. Easy to install with unique headbolt mounts. Kit includes all necessary mounting hardware. Sold in pairs.

44432-04		\$59.95
Fits '04-later XL and XR models.		

G. SPARK PLUG/HEADBOLT COVER – CHROME

Quickly add a chrome accent from the headbolt covers to the spark plug. Installs in seconds without tools.

43835-98		\$59.95
Fits '84-'99 Evolution® 1340-equipped models and '85-'03 XL models. (Does not fit Screamin' Eagle® Evolution Heads.)		

H. HEADBOLT COVERS

Precision-machined of high-quality aluminum and manufactured in the U.S.A. Hand-polished and chrome-plated. Available in a variety of styles to match your customizing direction, these kits include 4 easy-to-install headbolt covers, set screws and an Allen® wrench for easy installation.

Fits '86-later XL, '08-'13 XR, '85-'99 Evolution 1340 and '99-later Twin Cam models.

43822-01	Chrome-Billet.	\$42.95
43890-93	Chrome-Die Cut.	\$38.95
43896-99	Gloss Black.	\$41.95

I. CLUTCH CABLE CONNECTOR COVER

Add the finishing touch to your transmission. This chrome-plated die-cast cover conceals the clutch cable connector as it enters the primary cover. The two-piece grooved and tapered cover is easy to install and includes chrome-plated mounting hardware.

33401-05		\$29.95
Fits '00-later XL and XR models with cable-operated clutch.		



F. HEADBOLT BRIDGE – CHROME



G. SPARK PLUG/HEADBOLT COVER – CHROME



H. HEADBOLT COVERS – CLASSIC CHROME



H. HEADBOLT COVERS – GLOSS BLACK



I. CLUTCH CABLE CONNECTOR COVER



Notice: The prices appearing in this catalog are the manufacturer's suggested retail prices. Actual retail prices may vary.

124 SPORTSTER®

Chassis Trim

A. RIGHT SIDE OIL TANK COVER – CHROME

Like oil on blacktop, this Chrome Oil Tank Cover adds a brilliant sheen to the surface. Easy to install, the mirror-chrome cover follows the contour of the frame and blends perfectly with the pop-up dipstick. A perfect complement for the Chrome Left Side Battery Cover P/N 66261-04.

66262-04 Fits '04-'13 XL models. **\$114.95**

B. LEFT SIDE BATTERY COVER – CHROME

Designed to hug the contour of the frame, this mirror-chrome Battery Cover layers a splash of chrome to the left side of the bike. Easy to install, this cover is the ideal companion to the Chrome Oil Tank Cover P/N 66262-04.

66261-04 Fits '04-'13 XL models. **\$114.95**

C. SIDE COVER WING TIPS

Formed to hug the contour of the Sportster® Side Covers, the kit features three-dimensional trim with contrasting bright and brushed finishes for a distinctive appearance. A classic addition to painted or chrome side covers. Self-adhesive and easy to install, the kit includes left and right trim pieces.

66264-04 Fits '04-'13 XL models. **\$39.95**

D. OIL TANK COVER – CHROME

Chrome Oil Tank Cover gives the appearance of having your oil tank chromed. Installs in minutes. Mounting hardware included.

62512-97 **\$84.95**
Fits '94-'03 XL models (except models with Touring Seat P/N 52105-93, 52105-93A, 52105-93B and 52105-93C).

E. IGNITION MODULE COVER – CHROME

66328-82T Fits '82-'03 XL models. **\$27.95**

F. BATTERY SIDE COVER – CHROME

This chrome-plated cover is designed for use with the Harley-Davidson® AGM sealed maintenance-free batteries and can be used in combination with Battery Top Cover P/N 66367-97 or 66368-97.

66718-01 **\$49.95**
Fits '97-'03 XL models and '97-'05 Dyna® models.

G. BATTERY COVERS – CHROME*

Chrome-plated battery enclosures include slotted openings for convenient visual check of battery fluid levels. Easy installation.

1. 66340-78 Chrome Vented. **\$49.95**
Fits '82-'03 XL models, electric start FX, FXWG models and '91-'96 Dyna models.

2. 66358-83 U.S.A. Eagle. **\$59.95**
Fits '82-'03 XL models, electric start FX, FXWG models and '91-'96 Dyna models.

3. 66367-97 Top Cover. **\$29.95**
Fits '97-'03 XL models.

*NOTE: Battery dimensions of Harley-Davidson AGM Batteries P/N 65989-97A, 65989-90B and 65991-82B may not allow use of accessory battery side covers on XL and Dyna models.



A. RIGHT SIDE OIL TANK COVER – CHROME



B. LEFT SIDE BATTERY COVER – CHROME



C. SIDE COVER WING TIP



D. OIL TANK COVER – CHROME



E. IGNITION MODULE COVER – CHROME



F. BATTERY SIDE COVER – CHROME



G. BATTERY COVERS – CHROME

Notice: The prices appearing in this catalog are the manufacturer's suggested retail prices. Actual retail prices may vary.

SPORTSTER® 125

Oil Coolers



H. PREMIUM OIL COOLER KIT



H. PREMIUM OIL COOLER KIT



I. OIL COOLER COVER – SPORTSTER



J. OIL LEVEL AND TEMPERATURE DIPSTICK WITH LIGHTED LCD READOUT – CHROME



J. OIL LEVEL AND TEMPERATURE DIPSTICK WITH LIGHTED LCD READOUT – GLOSS BLACK



K. OIL DIPSTICK WITH TEMPERATURE GAUGE – '04-LATER SPORTSTER



K. OIL DIPSTICK WITH TEMPERATURE GAUGE – '82-'03 SPORTSTER

H. PREMIUM OIL COOLER KIT

This oil cooler was designed specifically for Harley-Davidson® to out-perform all other coolers in the industry. The cooler features a unique "Turbulator" system that evenly distributes oil across the cooling chambers. The air fins are designed to efficiently dissipate heat. The oil cooler has been designed to simplify installation and enhance performance. Kit comes complete with mounting hardware and pre-cut oil lines.

62700082 Side-Mount. **\$299.95**
Fits '04-later XL models. Does not include an integrated thermostat.

I. OIL COOLER COVER – SPORTSTER®

Add a beautiful accent to your Sportster® Premium Oil Cooler. This chrome cover is designed to allow proper airflow through the integrated duct work. Requires Grey Silicone RTV Adhesive P/N 99650-02 for installation.

63087-07 **\$49.95**
Fits '04-later XL models equipped with Premium Oil Cooler Kit P/N 62996-07A or 62700082.

J. OIL LEVEL AND TEMPERATURE DIPSTICK WITH LIGHTED LCD READOUT

No more grabbing a rag to pull your hot dipstick. No more oil drips on your pipes and on the garage floor. These stylish yet hard-working dipsticks allow you to check your oil level and oil temperature with the push of a button. Simply push the button and this dipstick lights up with a brilliant backlight. Oil level is indicated by a four-segment readout – it even reminds you to check your oil when it is hot. Capacitive level sensing technology provides the highest degree of accuracy and durability. The waterproof LCD (liquid crystal display) readout operates on a long-lasting, replaceable lithium coin-type battery (CR2032 3V, P/N 66000107). Display features a low battery indicator and press-and-hold feature to toggle between Fahrenheit and Celsius.

Fits '04-later XL and XR models.

62700009 Chrome. **\$149.95**
62700011 Gloss Black. **\$149.95**

K. OIL DIPSTICK WITH TEMPERATURE GAUGE

Replace your Original Equipment oil dipstick with this custom-styled version featuring an easy-to-see mechanical temperature readout with "Harley-Davidson" logo. A chrome-plated cap completes the styling and provides an easy grip for removal.

63023-05 Fits '04-later XL and XR models. **\$59.95**
62667-87TA Fits '82-'03 XL models. **\$34.95**

SPORTSTER

Notice: The prices appearing in this catalog are the manufacturer's suggested retail prices. Actual retail prices may vary.

126 SPORTSTER®

Chassis Trim & Horns

A. FLUSH-MOUNT FUEL CAPS

Emphasize the long and lean look of the fuel tank. This Flush-Mount Fuel Cap Kit offers a pop-up filler design that replaces the Original Equipment twist-on fuel cap. A simple push and the fuel filler cap pops up to provide ample grip, even while wearing gloves. Easy to install, the cap assembly screws into position and the self-adhesive decorative ring finishes the look. Complete kit includes screw-in mount, pop-up cap and matching trim ring.

Fits '98-later XL models equipped with 3.3 gal (12.5 L) fuel tank.

63133-10A	Chrome.	\$79.95
63134-10A	Gloss Black.	\$79.95

Fits '98-later XL models equipped with 2.1 gal (7.9 L) or 4.5 gal (17.0 L) fuel tank. Does not fit '04-'10 XL1200C models.

63139-10A	Chrome.	\$79.95
63140-10A	Gloss Black.	\$79.95



A. FLUSH-MOUNT FUEL CAP – CHROME



A. FLUSH-MOUNT FUEL CAP – GLOSS BLACK

B. LOUD HORN KIT

Grab everyone's attention. Engineered to be 3dB louder (at 2 meters) than the Original Equipment front-mounted horn, this Horn Kit is tuned to a frequency that helps cut through the background noise. Designed to be a plug-in replacement for the factory horn, this easy-to-install option is available in your choice of brilliant chrome or gloss black finish. The traditional Bar & Shield logo adds a classic finishing touch.

Fits '96-later XL and XR models with front-mount horn.

69000007	Chrome.	\$29.95
69000009	Gloss Black.	\$29.95



B. LOUD HORN KIT – CHROME



B. LOUD HORN KIT – GLOSS BLACK

C. SIDE-MOUNT HORN KIT – CHROME

Convert your stock Sportster® horn to the look of a Big Twin.

69112-95E		\$94.95
------------------	--	----------------

Fits '92-later XL883, XL883H, XL883C, XL883L, XL883N, XL833R, XL1200, XL1200L, XL1200N, XL1200R, XL1200V, XL1200X and '08-'13 XR models.



C. SIDE-MOUNT HORN KIT – CHROME

D. IGNITION SWITCH COVER – CHROME

A direct replacement for the stock black ignition switch cover, this chrome-plated cover is made of lightweight ABS plastic. Includes ignition switch position decal.

71527-04	Fits '04-'13 XL models.	\$21.95
71514-98	Fits '95-'03 XL models.	\$19.95



D. IGNITION SWITCH COVER – CHROME

E. BAR & SHIELD LOGO COIL COVER KIT

Dress your coil in chrome. The sleek Coil Cover is styled to add a custom touch to a very visible part of your Sportster motorcycle. Featuring mirror-finish chrome-plating and an open-face Bar & Shield logo, this easy-to-install kit includes chrome-plated mounting hardware.

31767-04	Fits '04-'06 XL models.	\$39.95
-----------------	-------------------------	----------------



E. BAR & SHIELD LOGO COIL COVER KIT

F. VOLTAGE REGULATOR COVER

With a look that creates its own electricity, this chrome-plated cover features an embossed Bar & Shield logo and an open-center grill that allows air to flow through for regulator cooling. Designed for easy installation. Chrome mounting hardware included.

74609-04	Fits '04-'06 XL models.	\$44.95
74579-97		\$44.95

Fits '85-'03 XL models. Will not fit with Front Spoiler P/N 58597-97, unless also equipped with the Sport Front Fender and the additional purchase of Voltage Regulator Hardware Kit P/N 74568-98.



F. VOLTAGE REGULATOR COVER

Notice: The prices appearing in this catalog are the manufacturer's suggested retail prices. Actual retail prices may vary.

SPORTSTER® 127

Chassis Trim



G. SIDE-MOUNT LICENSE PLATE KIT – CHROME



G. SIDE-MOUNT LICENSE PLATE KIT – BLACK

G. SIDE-MOUNT LICENSE PLATE KIT

Add a clean, custom look to the rear fender. This stylish kit moves the license plate from the fender to a side-mount location, visually lowering the bike's profile and opening up the view of the rear end. This strut-mounted hinged frame conceals the license mounting hardware and features a smooth back that hides the unfinished side of the plate. Kit includes LED license plate illumination and a curved Bar & Shield medallion, shaped to conceal the original license mounting holes in the fender. Purchase of tail lamp without license illumination window is recommended for models with center-mounted tail lights.

NOTE: License plate location and fold-away feature is regulated in many areas. Check local laws before installation.

Fits '04-later XL models (except XL1200T). Will not fit some International Specification '14-later XL883N (Iron 883) models with Original Equipment LED Turn Signals. See your dealer for details. Will not fit models equipped with rigid mount saddlebags, rigid mount sissy bars and Turn Signal Relocation Kit P/N 68732-02A and 68733-02A.

60947-10	Chrome.	\$199.95
60972-10	Black.	\$199.95

H. CHOPPED REAR FENDER KIT*

Complete "bolt-on" fender kit includes everything you need to convert your '04-later Sportster® model to the chopped rear fender look. Available in Vivid Black or Primed finish, this kit can be installed with simple tools and requires no frame modifications or fabrication. The chopped fender eliminates the traditional tail lamp and replaces the Original Equipment rear turn signals with "stop-turn-tail" lights for a clean, stripped-down appearance. All you need to add is a side mount or under-fender mount license plate bracket (sold separately).

NOTE: Laws regarding the location of the license plate vary from place to place. Please check with local authorities and obey all applicable laws and regulations.

Fits '07-'09 XL models (stock on XL1200N and XL883N). Requires separate purchase of Side Mount License Plate Assembly P/N 60318-07.

60236-09BEO	Primed.	\$419.95
60236-09DH	Vivid Black.	\$499.95

Fits '04-'06 and '10-later XL models (except XL1200T). Stock on XL1200V, XL1200X, XL1200N and XL883N. Will not fit some International Specification '14-later XL883N (Iron 883) models with Original Equipment LED Turn Signals. See your dealer for details. Requires separate purchase of Side Mount License Plate Assembly P/N 60318-07, 60947-10 or 60972-10.

60236-10BEO	Primed.	\$419.95
60236-10DH	Vivid Black.	\$499.95



H. CHOPPED REAR FENDER KIT (CUSTOM PAINTED)

I. CHOPPED FENDER EDGE LIGHT

Style and function in one. This center-mount running and brake light commands the attention of following vehicles. The bright, fast-acting LED lamp glows red when the ignition is on and intensifies when the brakes are applied. The low-profile lamp is contoured to hug the curve of the chopped rear fender and adds a stylish touch of color, even when the bike is parked.

68000105 Red Lens. **\$99.95**

Fits '14-later XL883N, XL1200V, XL1200X and '14-later models equipped with Chopped Rear Fender Kit P/N 60236-XX and side-mount license plate. Will not fit models with center-mount license plates.

73420-11 Red Lens. **\$89.95**

Fits '04-'13 XL883N, XL1200N, XL1200V, XL1200X and models equipped with Chopped Rear Fender Kit P/N 60236-XX and side-mount license plate. Will not fit models with center-mount license plates.



H. CHOPPED REAR FENDER KIT



I. CHOPPED FENDER EDGE LIGHT

FORUM P-H

*NOTE: This product is a "Paint to Order" accessory. Please allow for an average of 5 weeks delivery for this item.

Notice: The prices appearing in this catalog are the manufacturer's suggested retail prices. Actual retail prices may vary.

SPORTSTER