

Copie Privée

GENUINE MOTOR PARTS & ACCESSORIES



2015

TOURING & TRIKE

There's no better way to eat up the highway miles—be it on a wide-open two-lane or busy interstate—than on a Touring family motorcycle. Unmatched comfort, performance, and style to take you as far as you want to go.



TOURING

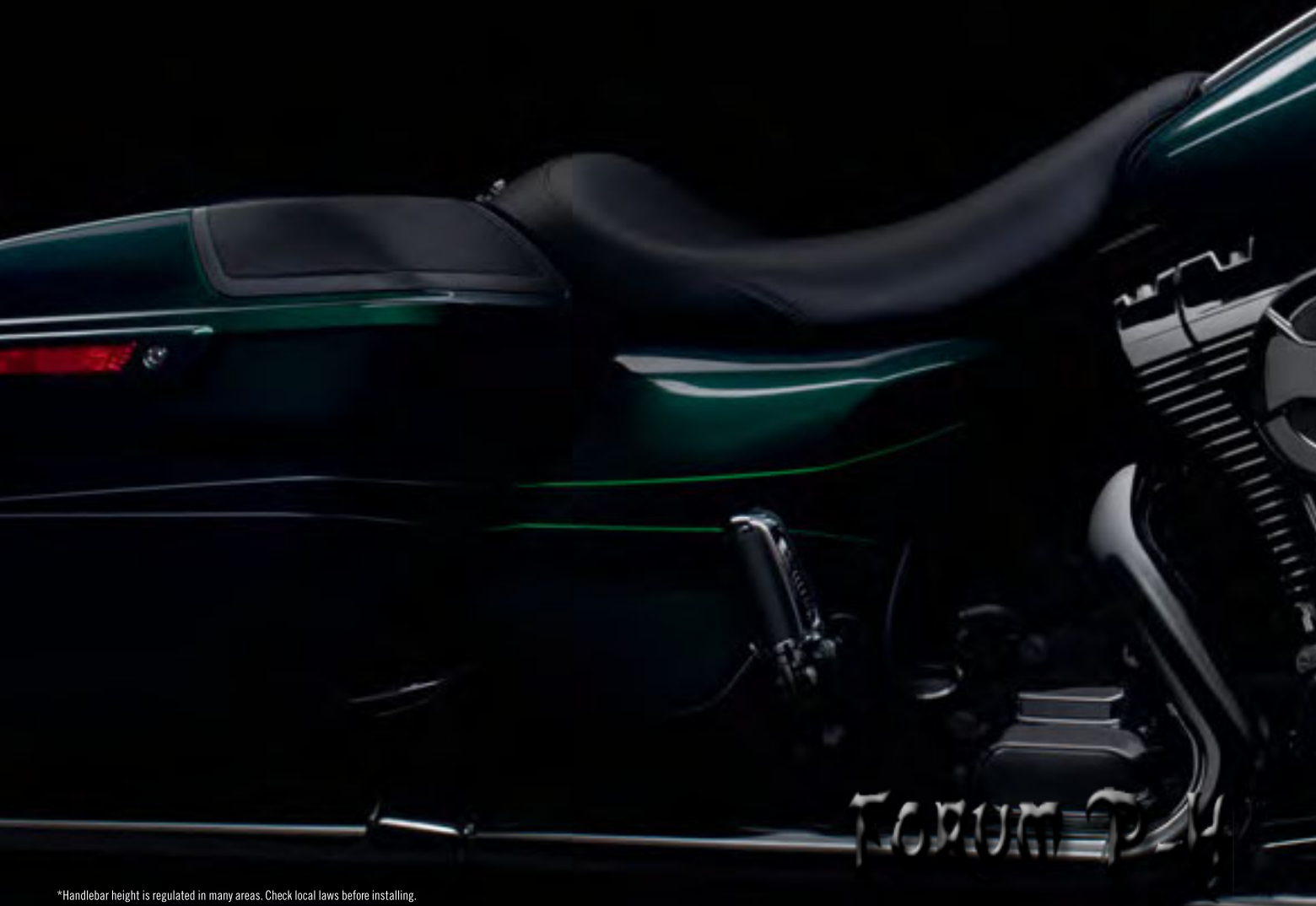

*Handlebar height is regulated in many areas. Check local laws before installing.





TOURING

WHAT'S NEW

For 2015, we've taken what was always great about the Harley-Davidson® Road Glide® model and made it even better. The sleek new frame-mounted fairing delivers a streamlined look and more "open" feel, even as it provides improved wind protection. New adjustable vents let you shape the wind to match your ride—just one of the many ways you can make this incredible bike your own.

FLTRXS | PRODUCTION COLOR: SUPERIOR BLUE

TRAVEL-PAK
TOUR-PAK® LINER

ROAD ZEPPELIN®
AIR ADJUSTABLE SEAT

BOOM!™ AUDIO
SADDLEBAG LID SPEAKERS

CHOPPED TOUR-PAK®
LUGGAGE

H-D® DETACHABLES™
TOUR-PAK® RACK

SCREAMIN' EAGLE®
STREET THUNDER MUFFLERS





BOOM!™ AUDIO
AMP & SPEAKER KIT

12" WIND SPLITTER
WINDSHIELD

COLOR-MATCHED
INNER FAIRING

ROAD GLIDE®
WINDSHIELD TRIM

CHROME HAND
CONTROLS

BOOM!™ AUDIO
HIDDEN ANTENNA

WIND DEFLECTORS

CHROME FRONT END KIT

VENTILATOR ELITE
AIR CLEANER

STEALTH FOOT CONTROLS

DAYMAKER™
LED FOG LAMPS

AGGRESSOR WHEELS & ROTORS



TOURING

ROAD KING®

FLHR | PRODUCTION COLOR: VIVID BLACK

This menacing Road King® motorcycle rules with an iron fist. The Black Ice Agitator wheels lead the way and connect the rider to the road through a blacked-out front end and 16" Fat Ape bar®. From the Street Stalker™ front fender to the tip of the CVO™ model-style rear fender, a Dark Custom™ attitude reigns, and bright red calipers lend a regal touch.



SEE WHAT'S ON THIS BIKE AT [H-D.COM/GALLERY](https://www.harley-davidson.com/gallery)

*Handlebar height is regulated in many areas. Check local laws before installing.



TOURING

ULTRA CLASSIC®

FLHTCU | PRODUCTION COLOR: MYSTERIOUS RED SUNGLO

Touring practicality and hot-rod style in one. Geared up for the road, this bike's Sundowner™ seat and 8-speaker BOOM!™ Audio sound system will keep you comfortable and entertained for hours in the saddle. And when you reach your destination, pop off the detachable Tour-Pak® luggage, twist the throttle, and prowl the streets in stripped-down style.





TOURING

ULTRA CLASSIC® LOW

FLHTCUL | PRODUCTION COLOR: AMBER WHISKEY/CHARCOAL PEARL

At first glance, this beautiful Ultra Low looks understated and elegant. But when the sun goes down and the lights come on, its true personality shines. LED headlamp and fog lamps light the road ahead, and LED saddlebag side and rear marker lighting commands the attention it deserves – especially from those lucky enough to be following along.





SEE WHAT'S ON THIS BIKE AT [H-D.COM/GALLERY](https://www.harley-davidson.com/gallery)



TOURING

ULTRA LIMITED

FLHTK | PRODUCTION COLOR: SUPERIOR BLUE

Luxury, style and performance—all the requirements of a couple traveling together. Unparalleled comfort from the Hammock seat and passenger armrests. Striking chrome accents. Non-stop entertainment from the 6-speaker BOOM!™ Audio sound system. Breathtaking acceleration with Screamin' Eagle® performance upgrades. This machine has it all.



TOURING

ULTRA LIMITED LOW

FLHTKL | PRODUCTION COLOR: DEEP JADE PEARL/VIVID BLACK

Luxury touring within almost any rider's reach. The low-profile suspension puts the rider closer to the ground. With a sleek Wind Splitter windscreen, blacked-out finishes, LED lighting, and premium 6-speaker BOOM!™ Audio sound system, there are no shortcuts when it comes to style.





TOURING

STREET GLIDE®

FLHX | PRODUCTION COLOR: MYSTERIOUS RED SUNGLO

Hit the country road if you want to, but this sleek Street Glide® model is just as eager to play with the urban crowd. Rich blacked-out finishes play in perfect harmony with the Mysterious Red, and the BOOM!™ Audio sound system and Street Cannon mufflers provide a silky soundtrack. Just relax in the Road Zeppelin® saddle, and turn up the volume.



SEE WHAT'S ON THIS BIKE AT H-D.COM/GALLERY

Handlebar height is regulated in many areas. Check local laws before installing.



TOURING

STREET GLIDE® SPECIAL

FLXS | COLORSHOP CUSTOM PAINT: LIMITED-ARCTIC FLASH

Black, white, and red all over. A blend of well-chosen extras help make this Street Glide® Special motorcycle something extra special. Color Shop Arctic Flash paint gets things started, and contrasting silver and black Agitator wheels and Burst Collection components finish the look. Then we tie it all together with complementing red brake calipers.





TOURING

ROAD GLIDE®

FLTRX | COLORSHOP CUSTOM PAINT: LIMITED - MIDNITE BLAZE

The Road Glide® motorcycle returns with a new look and a fresh attitude. This custom beauty features Midnite Blaze paint that sets the stage for blacked-out Agitator wheels, forks and engine trim, and then ups the ante with premium 4-speaker BOOM!™ Audio and Screamin' Eagle® performance upgrades. This is hot-rod bagger style at its finest.





TOURING

ROAD GLIDE® SPECIAL

FLTRXS | COLORSHOP CUSTOM PAINT: LIMITED-ARCTIC FLASH

Hit the road in glorious solitude. Stripped bare, this solo ride attracts attention wherever it goes. The blend of dark and light flows from the Color Shop Arctic Flash paint and continues to the contrast cut Burst Collection engine and chassis trim. But add a passenger pillion and the Chopped Tour-Pak® luggage, and you will never be alone again.





TOURING

FREEWHEELER™

FLRT | PRODUCTION COLOR: AMBER WHISKEY

Introducing the H-D® Freewheeler™ trike, the sleekest, sexiest three-wheeler around. This version sports a practical detachable windshield, Sundowner™ touring seat, passenger backrest and luggage rack, along with stylish chrome forks, blacked-out engine trim, and a raft of brilliant LED lighting. You'll stand out in a crowd wherever you ride.



POLICE
PROPERTY
CALL
800 182 1700

TOURING

TRI GLIDE® ULTRA

FLHTCUTG | PRODUCTION COLOR: VIVID BLACK

Vivid Black and chrome set the tone for this elegant Tri Glide® model, delivering high-end luxury in a three-wheeled package. Start with a heated Harley® Hammock touring seat. Add BOOM!™ Audio amp and speakers. Dress it up with Anarchy contrast chrome wheels. Layer on the chrome accents. And drive it home with LED headlamps and accent lighting.



SEE WHAT'S ON THIS BIKE AT [H-D.COM/GALLERY](https://www.harley-davidson.com/gallery)



STREET GLIDE® SPECIAL TRANSFORMATION

If you're looking for stripped-down bagger style, highway comfort, and modern technology, the Street Glide® Special motorcycle delivers it all—with a decidedly unruly attitude.

GREEN WITH ENVY

This sweet Street Glide® Special motorcycle is all about blurring the lines between a classic touring bike and hot-rod bagger. It starts with the rich Deep Jade Green finish that carries all the way through to the color-matched batwing inner fairing and stretched BOOM!™ Audio saddlebags.

It builds when everything else is dipped in chrome—from the Aggressor wheels and fork sliders to the tip of the Mini-Ape Handlebar* and the Nightstick exhaust. And it's finished with the addition of removable Chopped Tour-Pak® luggage. Only then do you get to see the complete picture.



CHOPPED TOUR-PAK® LUGGAGE

STRETCHED BOOM!™ AUDIO SADDLEBAGS

SCREAMIN' EAGLE® NIGHTSTICK MUFFLERS

BOOM!™ AUDIO SADDLEBAG SPEAKERS



FIT

Parts list available at h-d.com/gallery

Throw your fists to the wind with the Mini-Ape Handlebar*. Shaped to rest your hands just above the top of the classic batwing fairing, these bars feature a tall stance and minimal amount of pull back that help to achieve a cool yet comfortable riding profile.



FUNCTION

From a solo ride to work to a two-up ride across the country, the Street Glide® model can be anything you want it to be. With the turn of a thumbscrew, you change the seat—from the twist of the H-D® Detachables™ cam lock, you can install a backrest or Tour-Pak® luggage.



STYLE

Chrome is king. The wide-open Aggressor wheels and rotors add lightness to this Street Glide® model's profile, and focus your eye on the brilliant finish on the Twin Cam engine and Slipstream hand and foot controls.



PERFORMANCE

The Screamin' Eagle® Ventilator Elite air cleaner and Nightstick 2-into-2 mufflers work together to pass a large volume of air through the 103HO Twin Cam engine—delivering maximum performance and an aggressive exhaust note.





*Handlebar height is regulated in many areas. Check local laws before installing.

 CARE AND MAINTENANCE

While it's tempting to use standard "auto parts store" cleaning and service supplies, hold out for the real thing. Genuine Harley-Davidson® coolant, oils, filters, batteries and service parts are engineered for the unique surfaces and operating conditions your Harley® motorcycle will encounter.



LIGHTED SADDLEBAG LID SPOILERS



AGGRESSOR WHEELS & BRAKE ROTORS

 CRAFTSMANSHIP

We design and build the bikes, so we don't need to "reverse-engineer" parts to try and make them fit. Everything we make is rigorously tested to ensure it meets our high standards, and the finishes of our accessories match the bike's surfaces for a consistent appearance.



H-D® DETACHABLES™ PASSENGER BACKREST



BOOM!™ AUDIO BAGGER & SPEAKER KIT

336 TOURING & TRIKE

Windshields – Road King®

A. WIND SPLITTER VENTED WINDSHIELD

Reduce helmet buffeting at speed. The Harley-Davidson® Detachables™ Wind Splitter Vented Windshield features an exclusive fingertip-adjustable center vent that reduces turbulence behind the windscreen. When open, the controlled airflow fills the negative pressure area behind the shield and helps to smooth the flow of air over the top of the screen and around the rider. The revised flow reduces helmet bobbing and neck fatigue so you can comfortably spend more time in the saddle. The open vent also provides cooling airflow to the rider at low speeds and in city traffic.

Engineered to provide the riding comfort of a larger windshield, this low-profile screen's contemporary contour sets it apart from the crowd. The shape keeps the windshield below your site line so you don't look through bugs and road grime and the detachable design means you can ride without the shield when the mood strikes. The shield is formed of hard-coated polycarbonate for strength and scratch resistance and the dark-smoked finish reduces glare. The slim polished stainless steel brackets mount to the Original Equipment rubber isolated docking points for ease of installation and removal.

57400176 **\$429.95**

Fits '94-later Road King® models (except FLHRS). Does not fit with Mini Tach or Boom!™ Audio Cruiser Speakers Stock on '13-'14 FLHRSE. Windshield dimensions: Overall height – 22.4" height from headlamp opening – 16.1", width – 20.3".

B. VENTILATOR KING-SIZE H-D® DETACHABLES™ WINDSHIELD

In a nutshell, a windshield should provide a barrier between the rider and errant bugs, discarded cigarette butts, flying debris and bad air. The shield should manage airflow and wind blasts to create a pocket of still air for both rider and passenger comfort. But if you ride in a warm climate or spend time at low speeds stuck in traffic, you need to keep some air circulating around your body to stay comfortable. The Ventilator Windshield features clear injection-molded vents that allow you to adjust the airflow to match the riding conditions. Opening the vents redirects the air across your chest for a cooling effect and closing the vents provides maximum wind and weather protection. But when you want to ride "naked," the detachable shield can be removed completely and reinstalled in seconds to match your riding mood.

57400024 21" Clear. **\$379.95**

Fits '94-later Road King models. Will fit '04-later FLHRS models with the additional purchase of Mounting Hardware Kit P/N 58221-04. Windshield dimensions: Overall height – 28.0"; width – 22.0".



A. WIND SPLITTER VENTED WINDSHIELD



B. VENTILATOR KING-SIZE H-D DETACHABLES WINDSHIELD

Notice: The prices appearing in this catalog are the manufacturer's suggested retail prices. Actual retail prices may vary.

TOURING & TRIKE 337

Windshields – Road King®



C. ROAD KING H-D DETACHABLES WINDSHIELD – CLEAR

C. ROAD KING® H-D® DETACHABLES™ WINDSHIELDS

Designed to be installed or removed without tools in seconds, a detachable windshield gives you the freedom to define your ride at the drop of a hat. Ride across the country protected from the elements, then quickly remove the windshield to hit the streets in style. These one-piece windshields are formed from hard-coated polycarbonate material to resist scratching and the complete assembly features polished stainless brackets that mount to the Original Equipment rubber isolated docking points for ease of installation and removal. Windshields are available in a variety of heights to match your size and riding style.

Fits '94-later Road King® models. Will fit '04-later FLHRS models with the additional purchase of Mounting Hardware Kit P/N 58221-04.

57995-96 22" Clear. **\$334.95**
Windshield dimensions: Overall height – 29.0"; width – 23.1".

58325-06 18" Clear. **\$334.95**
Windshield dimensions: Overall height – 25.0"; width – 23.1".

57767-00 16" Clear. **\$309.95**
Windshield dimensions: Overall height – 23.0"; width – 23.1".

57981-97 16" Light Smoke. **\$349.95**
Windshield dimensions: Overall height – 23.0"; width – 23.1".

Also available:

ROAD KING CUSTOM WINDSHIELD DOCKING HARDWARE KIT

Kit includes the hardware required to install a H-D® Detachables™ Road King Windshield on the Road King Custom model.

58221-04 Fits '04-later FLHRS models. **\$29.95**

D. REPLACEMENT WINDSHIELD SCREEN

Formed of polycarbonate and available in a size that suits your riding needs. Kit includes screen, cross brace tape and instructions.

Fits '94-later Road King models (except FLHRSE5/6 models).

58433-96 22" Clear. **\$159.95**

58194-94 22" Light Smoke. **\$169.95**

58135-94 20" Light Smoke. **\$159.95**

57768-00 16" Clear. **\$144.95**

58195-94 16" Light Smoke. **\$159.95**



C. ROAD KING DETACHABLE WINDSHIELD – 16" LIGHT SMOKE



D. REPLACEMENT WINDSHIELD SCREEN

Notice: The prices appearing in this catalog are the manufacturer's suggested retail prices. Actual retail prices may vary.

338 TOURING & TRIKE

Windshields – Road King®

A. ROAD KING® 14" H-D® DETACHABLES™ WIND DEFLECTOR

Maintain the same low-down mini-shield styling of the Road King® Dark Smoke Wind Deflector with a little extra wind protection. This 3.0" taller oversized dark smoke screen features polished stainless steel mounting brackets to provide the same ease of installation as the stock Road King windshield.

57357-07 14" Dark Smoke. **\$329.95**
Fits '94-later Road King models. Will fit FLHRS models with the additional purchase of Mounting Hardware Kit P/N 58221-04. Stock on '07 FLHRSE models. Windshield dimensions: Overall height – 21.0"; width – 21.4".

B. ROAD KING 11" H-D DETACHABLES WIND DEFLECTOR

Keep the wind and glare out of your eyes with this Smoked Wind Deflector. This dark smoke detachable mini-shield follows the form of a traditional Harley-Davidson® Road King windshield, but its much smaller size adds a touch of low-down attitude.

58163-02 11" Dark Smoke. **\$309.95**
Fits '94-later Road King models. Will fit FLHRS models with the additional purchase of Mounting Hardware Kit P/N 58221-04. Stock on '08 FLHRSE2 models. Windshield dimensions: Overall height – 18.0"; width – 19.4".



A. ROAD KING 14" H-D DETACHABLES WIND DEFLECTOR



B. ROAD KING 11" H-D DETACHABLES WIND DEFLECTOR

C. REPLACEMENT 14" WINDSHIELD

Customize the wind deflector height on your Custom Vehicle Operations™ Road King motorcycle to match your riding style, without compromising the low-down look. Kit includes 3.0" taller dark smoke windshield, cushion cross brace tape and installation instructions. Requires reuse of Wind Deflector windshield brackets.

58799-02 14" Dark Smoke. **\$144.95**
Fits '02 FLHRSE models or Road King models equipped with Smoked Wind Deflector P/N 58163-02. Stock on '02 FLHRSE models. Windshield dimensions: Overall height – 21.0"; width – 21.4".



C. REPLACEMENT 14" WINDSHIELD

D. FRONT FORK AIR BAFFLE – CHROME

Deflect the cold night wind rushing between the fork tubes of your Touring model. This stylish chrome air baffle replaces the Original Equipment black baffle on '00-earlier models. Includes chrome mounting hardware.

58520-79TC **\$27.95**
Fits '80-'13 FLT, FLHT, FLHX and FLHR models. Does not fit Trike models.



D. FRONT FORK AIR BAFFLE – CHROME

E. FORK-MOUNT WIND DEFLECTORS – CHROME

Dress your bike for comfort and style. Wind Deflectors extend the windshield's coverage for superior protection in any weather. The scooped Deflectors are shaped to channel the air flow and direct the rush of air and turbulence around the rider. Deflectors attach to the fork brackets for a clean, integrated look and the chrome finish is the perfect complement to polished or chrome front end components. Easy-to-install kit includes all required mounting hardware.

57400146A **\$89.95**
Fits '95-later FLHR, FLHRC, FLHRS and '14-later FLHRSE models. Does not fit FLHT, FLHTC, FLHX and FLHXS models. Does not fit models equipped with Fairing Lowers. Does not fit '95-'13 models equipped with Lighted Fork Slider Kit or Custom Auxiliary Lighting Bracket Kit P/N 69227-04A or 68000043.



E. FORK-MOUNT WIND DEFLECTORS – CHROME

Notice: The prices appearing in this catalog are the manufacturer's suggested retail prices. Actual retail prices may vary.

NEW



F. H-D DETACHABLES 20" WINDSHIELD – FREEWHEELER MODELS

TOURING & TRIKE 339

Windshields – Freewheeler™

F. H-D® DETACHABLES™ WINDSHIELDS – FREEWHEELER™ MODELS

Designed to be installed or removed without tools in seconds, a detachable windshield gives you the freedom to define your ride at the drop of a hat. Ride across the country protected from the elements, then quickly remove the windshield to hit the streets in style. These one-piece windshields are formed from hard-coated polycarbonate material to resist scratching and the complete assembly features polished stainless brackets that mount to rubber isolated docking points for ease of installation and removal. Windshields are available in a variety of heights to match your size and riding style.

Fits '15-later FLRT models.

57400273	20" Clear.	\$349.95
57400274	16" Light Smoke.	\$359.95

NEW



F. H-D DETACHABLES 16" WINDSHIELD – FREEWHEELER MODELS

TOURING

Notice: The prices appearing in this catalog are the manufacturer's suggested retail prices. Actual retail prices may vary.

340 TOURING & TRIKE

Windshields – Electra Glide®

A. WIND SPLITTER WINDSHIELD – BATWING FAIRING

In the world of functional performance, size does matter. After all, it's simple to understand that the larger the windshield area, the greater the amount of wind deflection. The Wind Splitter Windshield is a great look for all Touring models and is shaped for the perfect combination of effective airflow management and "wow" styling. The sweeping design complements the shape of the fairing and the inner dash panel and adds height over a traditional low-profile wind deflector in the center where it counts. The shape decreases wind noise and improves your ability to hear the motorcycle's sound system. The rich smoked finish does not interfere with your forward view and looks great against any paint color. The easy-to-install Wind Splitter features a center-mount Bar & Shield medallion for a distinctive finishing touch.

Fits '14-later Electra Glide®, Street Glide® and Tri Glide® models.

57400204 4.5" Dark Smoke. **\$154.95**
Does not fit with Windshield Bags or Pouches.

57400205 7" Dark Smoke. **\$159.95**
Does not fit with Windshield Bags or Pouches.

57400206 10" Light Smoke. **\$164.95**

Fits '96-'13 Electra Glide®, Street Glide® and Trike models. Does not fit with zÜmo® 550 GPS Navigator, Windshield Bags or Pouches.

57400091 4.5" Dark Smoke. **\$159.95**

57164-10 7" Dark Smoke. **\$164.95**

57400092 10" Light Smoke. **\$169.95**



A. WIND SPLITTER WINDSHIELD – ELECTRA GLIDE
(4.5" DARK SMOKE SHOWN)



A. WIND SPLITTER WINDSHIELD – ELECTRA GLIDE
(7" DARK SMOKE SHOWN)



A. WIND SPLITTER WINDSHIELD – ELECTRA GLIDE
(10" LIGHT SMOKE SHOWN)

Notice: The prices appearing in this catalog are the manufacturer's suggested retail prices. Actual retail prices may vary.

TOURING & TRIKE 341

Windshields – Electra Glide®



B. BATWING FAIRING WINDSHIELDS



B. BATWING FAIRING WINDSHIELD – 15"



B. BATWING FAIRING WINDSHIELD – 12"



B. BATWING FAIRING WINDSHIELD – 10"



C. SPORT WINDSHIELD – 10"

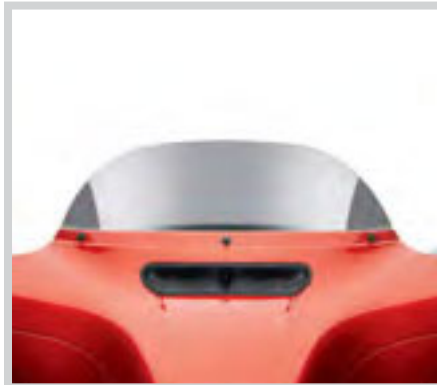

D. BATWING FAIRING WIND DEFLECTOR – MEDIUM PROFILE

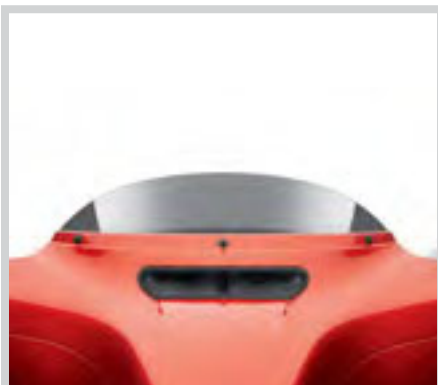

E. BATWING FAIRING WIND DEFLECTOR – LOW PROFILE



F. BATWING FAIRING 4" BLACK WIND DEFLECTOR

B. BATWING FAIRING WINDSHIELDS

Tailor your bike to your size and riding style. For the best compromise between adequate protection from the elements and a clear view of the road ahead, select a windshield that tops out just below eye level. This reduces helmet buffeting while allowing a view unobstructed by dirt, bugs and rain drops. Harley-Davidson® windshields are formed of hard-coated polycarbonate for strength and scratch resistance and are available in a variety of heights and tints to suit your riding needs.

Fits '14-later Electra Glide®, Street Glide® and Tri Glide® models.

57400224	15" Clear.	\$134.95
57400228	12" Clear.	\$134.95
57400226	12" Light Smoke.	\$134.95
57400227	10" Clear.	\$134.95
57400225	10" Light Smoke.	\$135.95

Fits '96-'13 Electra Glide, Street Glide and Trike models.

58314-97	15" Clear.	\$139.95
58187-96	12" Clear.	\$139.95
58302-96	12" Light Smoke.	\$139.95
58301-96	10" Clear.	\$139.95
58303-96	10" Light Smoke.	\$139.95

Fits '86-'95 FLHT models. (not shown)

58187-86	12" Clear.	\$149.95
-----------------	------------	-----------------

Fits '83-'85 FLHT models. (not shown)

58181-78	18.5" Clear.	\$149.95
-----------------	--------------	-----------------

C. SPORT WINDSHIELD

Combine the mini-shield styling of a wind deflector with a little extra wind protection. This 10.0" Sport Shield features a traditional wind screen shape, but adds a forward "flip" to the trailing edge to deflect the air flow over the rider. You get a shield that's still easy to look over, but without the turbulence usually associated with a short wind deflector. The light-smoke shield is formed from hard-coated polycarbonate for strength and scratch resistance.

57400213	10" Light Smoke.	\$159.95
-----------------	------------------	-----------------

Fits '14-later Electra Glide, Street Glide and Tri Glide models.

D. BATWING FAIRING WIND DEFLECTOR – MEDIUM PROFILE

Style meets function. This 7.0" tall Wind Deflector splits the difference between the wind deflector and a low windshield, offering sport styling with a little greater wind protection. Harley-Davidson windshields are formed of hard-coated polycarbonate for strength and scratch resistance and the dark smoke tint complements any paint color.

57400229	7" Dark Smoke.	\$134.95
-----------------	----------------	-----------------

Fits '14-later Electra Glide, Street Glide and Tri Glide models.

57185-05	7" Dark Smoke.	\$129.95
-----------------	----------------	-----------------

Fits '96-'13 Electra Glide, Street Glide and Trike models.

Stock on '05 FLHTCSE models.

E. BATWING FAIRING WIND DEFLECTOR – LOW PROFILE

Maintain your forward view with this low-profile wind deflector. The shield adds a radical shape to the traditional Batwing fairing and the dark smoke tint complements any paint color. Harley-Davidson windshields are formed of hard-coated polycarbonate for strength and scratch resistance.

57400243	5" Dark Smoke.	\$134.95
-----------------	----------------	-----------------

Fits '14-later Electra Glide, Street Glide and Tri Glide models.

Stock on '14 FLHX models.

58207-04	4" Dark Smoke.	\$129.95
-----------------	----------------	-----------------

Fits '96-'13 Electra Glide, Street Glide and Trike models.

Stock on '04 FLHTCSE models.

F. BATWING FAIRING 4" BLACK WIND DEFLECTOR

Opaque black 4.0" tall deflector provides radical styling for the ultimate custom cruiser.

58204-98	4" Dark Smoke.	\$129.95
-----------------	----------------	-----------------

Fits '96-'13 Electra Glide, Street Glide and Trike models.

TOURING

Notice: The prices appearing in this catalog are the manufacturer's suggested retail prices. Actual retail prices may vary.

342 TOURING & TRIKE

Windshields – Electra Glide®

A. CHROME WINDSHIELD TRIM – GROOVED

Custom polished and chrome-plated billet windshield trim accents the outer fairing and dresses your bike in style. The grooved design grabs your eye and adds character to the base of the windshield. Easy to install, the kit includes stainless steel mounting hardware.

61400224 **\$149.95**

Fits '14-later Electra Glide®, Street Glide® and Tri Glide® models.



A. CHROME WINDSHIELD TRIM – GROOVED

B. EDGE CUT WINDSHIELD TRIM

Live your life on the edge. Custom windshield trim features a crisp anodized finish that is machined to expose the high-lights of raw aluminum. The contrasting cut back look makes a powerful visual statement and works great with both traditional and contemporary customizing styles. Easy to install, the kit includes stainless steel mounting hardware.

61300358 **\$169.95**

Fits '14-later Electra Glide, Street Glide and Tri Glide models.

C. BAR & SHIELD WINDSHIELD TRIM

This highly polished stainless steel windshield trim is accented by four slots that allow the color of the outer fairing to show through. This unique trim piece is highlighted with Bar & Shield logo machined into the surface. Kit includes stainless steel mounting hardware.

61300275 **\$99.95**

Fits '14-later Electra Glide, Street Glide and Tri Glide models.

59133-99 **\$84.95**

Fits '96-'13 Electra Glide, Street Glide and Trike models.



B. EDGE CUT WINDSHIELD TRIM

D. CHROME WINDSHIELD MOLDING

Chrome Windshield Molding accents the outer fairing on Electra Glide models. Easily installed, including all necessary hardware and instructions.

61300310 **\$49.95**

Fits '14-later Electra Glide, Street Glide and Tri Glide models.

59123-96 **\$44.95**

Fits '96-'13 Electra Glide, Street Glide and Trike models.



C. BAR & SHIELD WINDSHIELD TRIM



D. CHROME WINDSHIELD MOLDING

Notice: The prices appearing in this catalog are the manufacturer's suggested retail prices. Actual retail prices may vary.



E. ADJUSTABLE AIR DEFLECTORS



F. ADJUSTABLE AIR DEFLECTOR KIT



G. FAIRING AIR DEFLECTORS



TOURING & TRIKE 343

Windshields – Electra Glide®

E. ADJUSTABLE AIR DEFLECTORS

The Adjustable Air Deflectors feature an infinitely adjustable friction pivot that holds the wing in position to direct the air where you need it. Close the vent to direct airflow around the fairing or open the vent to maximize airflow on hot days. Available in dark or light smoke finish, the translucent deflectors are easy to install with the included mounting hardware.

Fits '14-later Street Glide® models. Original Equipment on Electra Glide® and Tri Glide® models.

57000529 Dark Smoke. **\$119.95**

Fits '08-'13 Electra Glide, Street Glide and Trike models.

58156-08A Dark Smoke. **\$119.95**

58166-08A Light Smoke. **\$119.95**

F. ADJUSTABLE AIR DEFLECTOR KIT

Help keep your cool on hot summer rides. The smoked Adjustable Air Deflectors feature a spring-loaded detent system that locks in four different positions. Close the vent to direct airflow around the fairing or open the vent to maximize airflow on hot days. Easy to install, the complete kit includes left and right deflector and all necessary mounting hardware.

57804-07 Light Smoke. **\$119.95**

Fits '96-'13 Electra Glide, Street Glide and Trike models.

G. FAIRING AIR DEFLECTORS

Designed to deflect air away from the rider's elbows and upper torso, these easy-to-install Air Deflectors reduce the draft behind the fairing. Fixed-position deflectors are available in your choice of black or smoked finish to match your styling direction.

Fits '96-'13 Electra Glide, Street Glide and Trike models.

58568-98A Black. **\$39.95**

57740-05 Dark Smoke. **\$49.95**

58120-96A Light Smoke. **\$49.95**

Notice: The prices appearing in this catalog are the manufacturer's suggested retail prices. Actual retail prices may vary.

344 TOURING & TRIKE

Windshields – Road Glide®

A. WIND SPLITTER WINDSHIELD – ROAD GLIDE®

In the world of functional performance, size does matter. After all, it's simple to understand that the larger the windshield area, the greater the amount of wind deflection. The Wind Splitter Windshield is a great look for all Touring models and is shaped for the perfect combination of effective air flow management and "wow" styling. The sweeping design complements the shape of the fairing and the inner dash panel and adds height over a traditional low-profile wind deflector in the center where it counts. The shape decreases wind noise and improves your ability to hear the motorcycle's sound system. The rich smoked finish does not interfere with your forward view and looks great against any paint color. The easy-to-install Wind Splitter features a center-mount Bar & Shield medallion for a distinctive finishing touch.

Fits '15-later Road Glide® models.

57400271	12" Light Smoke.	\$194.95
57400270	15" Light Smoke.	\$209.95

Fits '98-'13 Road Glide models.

57400093	9" Dark Smoke.	\$159.95
57166-10A	12" Dark Smoke.	\$164.95
57400094	15" Light Smoke.	\$169.95



NEW



NEW

A. 12" WIND SPLITTER WINDSHIELD – (57400271 SHOWN)



NEW



NEW

A. 15" WIND SPLITTER WINDSHIELD – (57400270 SHOWN)



A. 9" WIND SPLITTER WINDSHIELD – ROAD GLIDE
(57400093 SHOWN)



A. 12" WIND SPLITTER WINDSHIELD –
(57166-10A SHOWN)



A. 15" WIND SPLITTER WINDSHIELD –
(57400094 SHOWN)

Notice: The prices appearing in this catalog are the manufacturer's suggested retail prices. Actual retail prices may vary.

TOURING & TRIKE 345

Windshields – Road Glide®

NEW



B. ROAD GLIDE 19" WINDSHIELD

NEW



B. ROAD GLIDE 15.5" WINDSHIELD

B. ROAD GLIDE® WINDSHIELDS

Tailor your bike to your size and riding style. For the best compromise between adequate protection from the elements and a clear view of the road ahead, select a windshield that tops out just below eye level. This reduces helmet buffeting while allowing a view unobstructed by dirt, bugs and rain drops. Harley-Davidson® windshields are formed of hard-coated polycarbonate for strength and scratch resistance and are available in a variety of heights to suit your riding needs.

Fits '15-later Road Glide® models.

57400279 19" Clear. **\$169.95**

57400281 15.5" Clear. **\$159.95**

C. ROAD GLIDE 19" WINDSHIELD – CLEAR

The tall windshield is approximately 3" taller than stock and is hard-coated for durability.

58283-04B Fits '04-'13 Road Glide models. **\$174.95**

D. ROAD GLIDE 10" WINDSHIELD – LIGHT SMOKE

This low-profile windshield option is approximately 6" shorter than stock with a light smoke tinted look. The windshield is hard-coated for durability.

58284-04B Fits '04-'13 Road Glide models. **\$159.95**

E. ROAD GLIDE 7" CONTOURED WIND DEFLECTOR – LIGHT SMOKE

Go low with this light smoke Road Glide® model windshield that is contoured for a unique style. Stock on FLTRSEI2 models.

58753-01B Fits '04-'13 Road Glide models. **\$144.95**



C. ROAD GLIDE 19" WINDSHIELD – CLEAR (SHOWN WITH ROAD GLIDE WINDSHIELD TRIM)



D. ROAD GLIDE 10" WINDSHIELD – LIGHT SMOKE (SHOWN WITH ROAD GLIDE WINDSHIELD TRIM)



E. ROAD GLIDE 7" CONTOURED WIND DEFLECTOR – LIGHT SMOKE

Notice: The prices appearing in this catalog are the manufacturer's suggested retail prices. Actual retail prices may vary.

346 TOURING & TRIKE

Windshields – Road Glide®

A. ROAD GLIDE® CONTOURED WIND DEFLECTOR – BLACK

Go low with this Road Glide® model windshield that is contoured for a unique style.

57400280 6" Black. **\$139.95**

Fits '15-later Road Glide models. Original Equipment on '15-later FLTRX and FLTRXS models.

57988-09 **\$149.95**

Fits '98-'13 Road Glide models. Will not fit with Road Glide Windshield Trim P/N 58519-07.

B. ROAD GLIDE 5" WIND DEFLECTOR – BLACK

Opaque black deflector provides radical styling for the ultimate custom cruiser.

57957-98A **\$119.95**

Fits '98-'13 Road Glide models. Will fit with Road Glide Windshield Trim P/N 58519-07.

C. ROAD GLIDE WIND DEFLECTOR KIT

Easy to install, these snap-fit Wind Deflectors reduce and redirect the airflow that rises between the fairing and fork tubes. The resulting reduction in updraft can dramatically reduce buffeting for many riders.

57000510 **\$39.95**

Fits '15-later Road Glide models. Stock on '15 FLTRUSE.

57000063 **\$39.95**

Fits '98-'13 Road Glide models. (Will not fit models equipped with the Fuel Tank retrofit mounting kit.) Stock on '11-'13 CVO™ Road Glide.

NEW



A. ROAD GLIDE CONTOURED WIND DEFLECTOR – BLACK (57400280 SHOWN)



A. ROAD GLIDE 6" CONTOURED WIND DEFLECTOR – BLACK (57988-09 SHOWN)



B. ROAD GLIDE 5" WIND DEFLECTOR – BLACK



C. ROAD GLIDE WIND DEFLECTOR KIT



C. WIND DEFLECTOR – (57000510 SHOWN)



C. WIND DEFLECTOR – (57000063 SHOWN)

Notice: The prices appearing in this catalog are the manufacturer's suggested retail prices. Actual retail prices may vary.

NEW

TOURING & TRIKE 347

Windshields – Road Glide®

D. ROAD GLIDE® SPLIT WINDSHIELD TRIM

Stock on the 2015 CVO™ Road Glide®, this easy to install, 2 piece trim kit adds a speedy looking splash of chrome to the base of the windshield.

57400299 Chrome. **\$119.95**
Fits '15-later Road Glide models. Stock on '15 FLTRUSE models.

E. ROAD GLIDE WINDSHIELD TRIM

The fairing is a key visual element of your bike, so it demands the bold design of this elegant contoured windshield trim. This sweeping trim hugs the curvature of the fairing and conceals the base of the windshield and the windshield gasket for a clean, finished look. The multi-piece design simplifies installation. Kit includes mounting hardware and "Road Glide" medallion.

Fits '04-'13 Road Glide models (except FLTRXSE and FLTRUSE).

58519-07A Chrome. **\$149.95**
57400150 Gloss Black. **\$149.95**



D. ROAD GLIDE SPLIT WINDSHIELD TRIM



E. ROAD GLIDE WINDSHIELD TRIM – CHROME
(SHOWN WITH CONTOURED WIND DEFLECTOR)



E. ROAD GLIDE WINDSHIELD TRIM – GLOSS BLACK
(SHOWN WITH WIND SPLITTER WINDSHIELD)

TOURING

Notice: The prices appearing in this catalog are the manufacturer's suggested retail prices. Actual retail prices may vary.

348 TOURING & TRIKE

Fairing Accessories

A. THREE-POCKET FAIRING POUCH

Convenient storage space at your fingertips. Designed to complement H-D® wind deflectors and windshields, this fairing pouch is ideal for storing mobile devices, sunglasses and other small items. The sturdy plastic pouches are wrapped in supple UV-resistant vinyl for a premium look and feel and the magnetic closures keep your items within reach without detracting from the tastefully smooth styling.

93300054A **\$129.95**

Fits '14-later Electra Glide®, Street Glide® and Tri Glide® models with windshields. Not for use with Wind Splitter Windshields P/N 57400204 or 57400205, H-D® Detachables™ Two-Up Tour-Pak Mounting Rack or any H-D Detachables Two-Up Luggage Rack.



A. THREE-POCKET FAIRING POUCH – '14-LATER MODELS

B. THREE-POCKET FAIRING POUCH

Convenient storage space at your fingertips. Designed to complement H-D wind deflectors and windshields, this fairing pouch is ideal for storing cell phones, sunglasses and other small items. The sturdy plastic pouches are wrapped in supple UV-resistant vinyl for a premium look and feel and the magnetic closures keep your items within reach, while not detracting from the tastefully smooth styling. The left-hand pouch can be easily removed to accommodate your fairing-mounted GPS unit. Attractive Harley-Davidson script is featured on the front center pouch and on the outboard – facing side, visible through the windshield.

58900-11 **\$114.95**

Fits '96-'13 Electra-Glide, Street Glide and Trike models. Not for use with Fairing Dash Pads. Models equipped with Illuminated Windshield Molding P/N 57335-08 requires separate purchase of Screws P/N 4456 (qty 3), Bar & Shield Windshield Molding P/N 59133-99 requires separate purchase of Screws P/N 94386-92T (qty 3), Chrome Windshield Molding P/N 59213-96 requires separate purchase of Screws P/N 94397-91T (qty 3).



B. THREE-POCKET FAIRING POUCH – '96-'13 MODELS

C. ELECTRA GLIDE LEATHER FAIRING POUCH

Easily installed inner fairing pouch is designed to hold sunglasses, cell phones or riding gloves. All-leather construction around a molded ABS plastic base for shape retention. Has an easy-to-use full-length hook-and-loop closure and features a black embroidered Bar & Shield logo on the lid.

58248-96 **\$109.95**

Fits '96-'13 Electra Glide and Tri Glide models. Does not fit with Original Equipment or accessory Wind Deflectors. Does not fit with Fairing Mounted GPS Navigation Systems.



B. THREE-POCKET FAIRING POUCH – '96-'13 MODELS
(SHOWN WITH GPS UNIT)



C. ELECTRA GLIDE LEATHER FAIRING POUCH

Notice: The prices appearing in this catalog are the manufacturer's suggested retail prices. Actual retail prices may vary.

TOURING & TRIKE 349

Wind Deflectors



D. ELECTRA GLO FAIRING EDGE LIGHT KIT

D. ELECTRA GLO™ FAIRING EDGE LIGHT KIT

Amplify your ride. The Electra Glo™ Fairing Edge Light Kit adds forward-facing white LED accent lights to the front profile of your bike. Formed to follow the contour of the batwing fairing, the slim strip of lamps adds a strong visual element to the iconic shape of the Electra Glide® model. The electrifying appearance adds conspicuity to get you noticed and the smoked housing conceals the lights and blends into the background when switched off. Simple "plug in" connections with no cutting or splicing of wires required.

68000104 **\$99.95**

Fits '14-later Electra Glide, Street Glide® and Tri Glide® models.

68000035 **\$99.95**

Fits '96-'13 Electra Glide, Street Glide and Trike models.

E. MID-FRAME AIR DEFLECTOR

Designed for severe duty and extreme temperature applications. These black deflectors attach to the frame below the seat and direct heat away from the rider to improve comfort.

58002-09 **\$79.95**

Fits '09-later Touring and Trike models. Original Equipment on FLHTCU, FLHTCUTG, FLTRU and FLHTK models.

58022-07A **\$79.95**

Fits '01-'08 Touring models. Does not fit '01-'07 models equipped with Adjustable Rider Backrests.

F. MID-FRAME AIR DEFLECTOR TRIM

This injection-molded trim adds a touch of chrome to the Mid-Frame Air Deflectors on touring vehicles. These chrome accents blend the look of chrome from the engine and help make the deflectors look integrated with the bike.

61400028 **\$59.95**

Fits '09-later Touring and Trike models equipped with Mid-Frame Air Deflectors.

G. SOFT LOWERS

Extend your riding season. Full coverage Soft Lower provide wind and mud protection for the rider's legs and boots and minimize cold updrafts as the weather changes. Covers are custom shaped to hug the engine guard to minimize flapping and they simply clip in place for speedy installation as the weather changes. Two-way zippered outer edge accommodates guard-mounted highway pegs in almost any position. Reflective piping provides added visibility and convenient zippered pockets provide additional storage for maps or other small items.

57100210 **\$89.95**

Fits '80-later Touring and Trike models equipped with engine guards. Does not fit Mustache Engine Guards. Does not fit models with Extended Reach Brake Lever or Extended Reach Shift Lever.



E. MID-FRAME AIR DEFLECTOR



F. MID-FRAME AIR DEFLECTOR TRIM



G. SOFT LOWERS – FRONT VIEW



G. SOFT LOWERS – REAR VIEW

Notice: The prices appearing in this catalog are the manufacturer's suggested retail prices. Actual retail prices may vary.

350 TOURING & TRIKE

Fairing Lower



ROAD KING SHOWN WITH COLOR-MATCHED VENTED FAIRING LOWERS

A. Color-Matched Vented Fairing Lower

Color	'83-'13		'14-later	
	P/N	Price	P/N	Price
Unpainted	58854-05	\$499.95	57100258	\$449.95
Amber Whiskey	—	—	57100257DST	\$699.95
Anniversary Vintage Black	58854-13DME	\$674.95	—	—
Big Blue Pearl	58854-12DJO	\$674.95	57100257DJO	\$699.95
Birch White	58854-05AV	\$674.95	—	—
Black Cherry	58854-05BPS	\$674.95	—	—
Black Denim	58854-09BYM	\$674.95	57100257BYM	\$699.95
Black Magic	—	—	57100257DWV	\$699.95
Black Pearl	58854-05BPY	\$674.95	—	—
Blackened Cayenne	—	—	57100257DSZ	\$699.95
Brilliant Silver	58854-05BHT	\$674.95	57100257BHT	\$699.95
Burnt Emerald	58854-13DRC	\$849.95	—	—
Candy Orange	58854-13DPU	\$674.95	—	—
Charcoal Pearl	—	—	57100257DTF	\$699.95
Charcoal Satin	—	—	57100257DUM	\$699.95
Chrome Yellow	58854-12DGV	\$674.95	—	—
Chrome Yellow Pearl	58854-13DPR	\$674.95	—	—
Cool Blue Pearl	58854-11DGR	\$674.95	—	—
Copper Pearl	58854-08CPH	\$674.95	—	—
Crimson Red Sunglo	58854-08COZ	\$674.95	—	—
Daytona Blue	—	—	57100257DUA	\$699.95
Deep Cobalt	58854-06BXT	\$674.95	—	—
Deep Jade Pearl	—	—	57100257DWF	\$699.95
Deep Purple	58854-12DKM	\$674.95	—	—

Color	'83-'13		'14-later	
	P/N	Price	P/N	Price
Ember Red Sunglo	58854-12DJS	\$674.95	—	—
Flame Blue Pearl	58854-09CWA	\$674.95	—	—
Galaxy Grey	58854-13CPB	\$849.95	—	—
Merlot Sunglo	58854-10DCE	\$674.95	—	—
Midnight Pearl	58854-12DKJ	\$674.95	—	—
Morocco Gold	—	—	57100257DTC	\$699.95
Mysterious Red Sunglo	—	—	57100257DSW	\$699.95
Obsidian	58854-13DRJ	\$849.95	—	—
Pewter Pearl	58854-07CGR	\$674.95	—	—
Radioactive Green	—	—	57100257DWJ	\$699.95
Red Hot Sunglo	58854-09CYS	\$674.95	—	—
Sand Camo Denim	—	—	57100257DSR	\$699.95
Sand Pearl	—	—	57100257DUN	\$699.95
Scarlet Red	58854-10DBJ	\$674.95	—	—
Sedona Orange	58854-11DGX	\$674.95	—	—
Spiced Rum	58854-10DEK	\$849.95	—	—
Starfire Black	58854-12DLO	\$849.95	—	—
Superior Blue	—	—	57100257DWC	\$699.95
Tequila Sunrise ('10 FLHXSE)	58854-10DEM	\$849.95	—	—
Tequila Sunrise	58854-12DKO	\$674.95	—	—
Vivid Black	58854-05DH	\$674.95	57100257DH	\$699.95
White Gold Pearl	58854-07CGS	\$674.95	—	—
White Hot Denim	58854-11DHA	\$674.95	—	—
White Hot Pearl	58854-13DJI	\$674.95	—	—

Notice: The prices appearing in this catalog are the manufacturer's suggested retail prices. Actual retail prices may vary.

TOURING & TRIKE 351

Fairing Lower

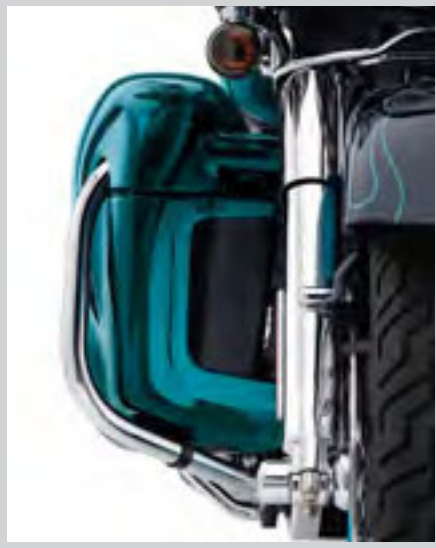

A. VENTED FAIRING LOWER – OPEN



A. VENTED FAIRING LOWER – CLOSED



A. COLOR-MATCHED VENTED FAIRING LOWER KIT – '14-LATER MODELS



A. COLOR-MATCHED VENTED FAIRING LOWER KIT – '83-'13 MODELS



B. COLOR-MATCHED ROAD GLIDE NON-VENTED FAIRING LOWER KIT



C. NON-VENTED FAIRING LOWER

A. COLOR-MATCHED VENTED FAIRING LOWER KIT*

Control the airflow to your lower legs for maximum riding comfort. Original Equipment on many Touring models, these Color-Matched Fairing Lower feature a venting system that allows you to adjust the amount of air that circulates across the engine. On hot days, open the vent to direct additional cooling air and on cold or rainy days, close the vents for maximum protection from the elements. The ratcheting friction lock pivot allows you to easily set the position. The complete kit includes left and right Fairing Lower, convenient glove box and lid and all necessary mounting hardware. Glove Box Doors are sold separately. NOTE: Fairing Lower Kits are painted in a single color and do not feature pinstriping.

Fits '14-later air-cooled Touring and Trike models. Does not fit Twin-Cooled™ models. Freewheeler™ models require separate purchase of Engine Guard P/N 49184-09A or 49050-09A and Steering Stabilizer Bracket P/N 83865-09. Does not fit with Mustache Engine Guards.

57100258	Unpainted.	\$449.95
See Matrix	Color-Matched.	—

Fits '83-'13 Touring (except '98-'09 FLTR) and Trike models. Stock on FLHTCU, FLHTK and FLHTCUTG. Models without Engine Guard will require the installation of Engine Guard P/N 49066-09 or 49050-09, Screw P/N 4924 (2), Washer P/N 2708A (1). Will not fit with Mustache Engine Guards. FLHXXX models also require the installation of Steering Stabilizer Bracket P/N 83865-09. Does not fit with Front Fender Adapter Kit 59013-02A or standard-size Heavy Breather Air Cleaner. Models equipped with Heavy Breather Air Cleaner require separate purchase of Compact Heavy Breather Kit P/N 28716-10.

58854-05	Unpainted.	\$499.95
See Matrix	Color-Matched.	—

B. ROAD GLIDE® NON-VENTED FAIRING LOWER KIT*

The unique lines of the Road Glide® models are accentuated with these fairing lowers. Available with Color-Matched factory paint or in primed finish, ready to apply your own custom design. Glove Boxes are sold separately. NOTE: All fairing lower kits are painted with a single color scheme and do not include pinstripes. FLTR and FLTRI models equipped with Stainless Steel Braided Clutch Cable P/N 38660-00A require separate purchase of Service Kit P/N 38674-01.

Fits '04-'09 FLTR/I models. (Does not fit with Front Fender Adapter Kit 59013-02A.)

58861-04BDK	Unpainted.	\$599.95
58861-04DH	Vivid Black.	\$824.95

C. NON-VENTED FAIRING LOWER*

Made from tough, lightweight vacuum-formed ABS, these fairing lowers protect the rider from the elements and direct cooling air to the engine. Lower attach to the engine guard without interfering with rider footboards. Kit includes all necessary mounting hardware. Glove Boxes are sold separately. NOTE: All fairing lower kits are painted with a single color scheme and do not include pinstripes.

Fits '83-'13 FLHT, FLHTC, FLHX and FLHR models. Does not fit with Front Fender Adapter Kit 59013-02A, Mustache Engine Guard P/N 49155-05, 49155-09A or 49442-10, Front Bullet Turn Signal Kit P/N 69492-05 and 69493-05. (NOTE: Requires drilling a hole in the left side fairing lower for the engine guard filler valve on '84-'87 models.)

58830-88DH	Vivid Black.	\$674.95
-------------------	--------------	-----------------

*NOTE: This product is a "Paint to Order" accessory. Please allow for an average of 5 weeks delivery for this item.

Notice: The prices appearing in this catalog are the manufacturer's suggested retail prices. Actual retail prices may vary.

352 TOURING & TRIKE

Fairing Lower

A. FAIRING LOWER FITTED GLOVE BOX LINER KIT

Protect your belongings and reduce noise and rattles on the road. Soft-touch felt finish liner is formed to the fairing glove box interior for a perfect fit. Molded base and sides maximize the interior room and one-piece design allows easy removal for cleaning and maintenance.

57100270 **\$39.95**

Fits '14-later Touring and Trike models equipped with Original Equipment or accessory Vented Fairing Lower. Does not fit Twin-Cooled™ models.

58714-06 **\$29.95**

Fits '05-'13 Touring and Trike models equipped with Vented Fairing Lower.



A. FAIRING LOWER FITTED GLOVE BOX LINER KIT



B. ROAD GLIDE® COMPARTMENT LINERS

Protect your belongings and reduce noise and rattles on the road. Soft-touch felt finish liner is formed to the fairing glove box interior for a perfect fit. Molded base and sides maximize the interior room and one-piece design allows easy removal for cleaning and maintenance.

76000539 **\$39.95**

Fits '15-later Road Glide® models. Right liner includes integrated mobile device storage net.

58932-98 **\$29.95**

Fits '98-'13 Road Glide models.



NEW

B. ROAD GLIDE COMPARTMENT LINERS
(76000539 SHOWN)



B. ROAD GLIDE COMPARTMENT LINERS
(58932-98 SHOWN)

C. FAIRING LOWER QUICK-RELEASE HARDWARE KIT

Beat the summer heat and prepare for around-town cruising by removing the fairing lowers on your Ultra Classic® Electra Glide® model. This kit includes highly polished stainless steel clamps that are detachable without the need for tools.

47200240 **\$129.95**

Fits '14-later FLHTCU and FLHTCUL models. Also fits '14-later Touring models equipped with Accessory Fairing Lower. Does not fit Twin-Cooled models or models equipped with fairing lower speakers.

58146-07 **\$99.95**

Fits '05-'13 Touring and Trike models equipped with Vented Fairing Lower and '88-later Touring and Trike models equipped with Vented Fairing Lower Kit 58854-YYXXX. Does not fit models equipped with fairing lower speakers.



C. FAIRING LOWER QUICK-RELEASE
HARDWARE KIT –
'14-LATER MODELS



C. FAIRING LOWER QUICK-RELEASE
HARDWARE KIT –
'05-'13 MODELS

D. FAIRING LOWER SOFT STORAGE BAG

Protect your fairing lowers when they are removed for hot weather riding. This convenient storage bag features a heavy-weight 10-oz. cotton exterior and sturdy carrying handle. Dual zippers open to expose a soft felt interior with a sturdy divider for left and right lowers and two zippered pouches for loose hardware storage. A classic embroidered Bar & Shield logo adorns the bag's exterior.

95983-07 **\$79.95**

Fits all styles of Harley-Davidson® Fairing Lower (except Twin-Cooled models).



C. FAIRING LOWER QUICK-RELEASE
HARDWARE KIT



D. FAIRING LOWER SOFT STORAGE BAG

Notice: The prices appearing in this catalog are the manufacturer's suggested retail prices. Actual retail prices may vary.

TOURING & TRIKE 353

Fairing Lower



E. FAIRING LOWER QUICK FLAP MAGNETIC DOORS



E. FAIRING LOWER QUICK FLAP MAGNETIC DOORS

The Quick Flap Door Kit enables quick and easy access to fairing lower glove boxes. The flexible covers feature high-strength magnetic catches that replace the Original Equipment snap closures for one-handed access. Kit includes left and right side doors and magnetic catches. Combine with available Glove Box Liners for rattle-free storage.

57100198 **\$54.95**

Fits '83-'13 Road King®, Electra Glide®, Street Glide® and Trike models equipped with vented and non-vented Fairing Lower Glove Boxes and '10-'13 Road Glide® models equipped with vented Fairing Lower Glove Boxes.

F. FAIRING LOWER LOCKING GLOVE BOX DOORS

Keyed-to-match security. Add secured storage to your fairing lowers. This Locking Glove Box Door Kit replaces the Original Equipment flexible snap-on covers and provides convenient, weather-resistant storage for documents, cell phones and sunglasses. The kits are "keyed to match" to your motorcycle ignition, for barrel style keys, for "one key" convenience. This locking door kit is an ideal companion to the Fitted Glove Box Liner Kit P/N 58714-06. Kit includes left and right locking door assemblies and door frames.

57411-08 **\$195.95**

Fits '91-'13 Touring and Trike models equipped with Electra Glide Ultra style fairing lowers. Also fits accessory fairing lowers, vented and non-vented. Does not fit with Glove Box Door Pouches P/N 57400-06.



F. FAIRING LOWER LOCKING GLOVE BOX DOORS



G. FAIRING LOWER GLOVE BOX DOOR POUCHES

Pouches fit perfectly on your glove box doors to provide convenient storage of small items at your fingertips. Made of a ballistic nylon exterior and a soft, fuzzy interior with elastic sides for expandability. Perfect for your cell phone, digital media player, tollway pass or any other small items. Reinforced cover features an embroidered Bar & Shield logo. Kit includes left and right pouches.

57400-06 **\$34.95**

Fits '91-'13 Touring and Trike models equipped with vented fairing lowers. Does not fit with Locking Glove Box Door P/N 57411-08.



G. FAIRING LOWER GLOVE BOX DOOR POUCHES



H. FLT AND FLHT FAIRING LOWER GLOVE BOXES

Offers a convenient place to store riding gloves, sunglasses, etc. The snap-on door cover (included) is embossed with Bar & Shield logo. Available in black only.

Ultra Classic® Styling

58683-89B Left Side. **\$169.95**

Fits '04-earlier Original Equipment non-vented style FLHT Ultra Classic® Fairing Lower.

58684-89B Right Side. **\$169.95**

Fits '04-earlier Original Equipment non-vented style FLHT Ultra Classic Fairing Lower.

58687-89 Left Side. **\$169.95**

Fits '98-'09 non-vented style FLT and FLTR Fairing Lower.

58688-89A Right Side. **\$169.95**

Fits '98-'09 non-vented style FLT and FLTR Fairing Lower.



H. FLT AND FLHT FAIRING LOWER GLOVE BOXES



Notice: The prices appearing in this catalog are the manufacturer's suggested retail prices. Actual retail prices may vary.

SEAT OF POWER

The right seat is equal parts ergonomics and comfort. Its shape anchors your position and determines the reach to the ground and to the controls and the padding supports your tailbone and hips to relieve stress and pressure. Pick the right one for you – and your passenger.



TALLBOY® SEAT



SUPER REDUCED REACH® SEAT

LAP OF LUXURY

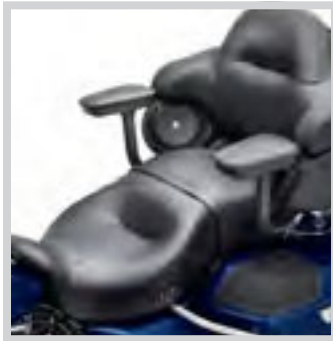

If your passenger is happy, you'll be happy. Premium passenger armrests have been ergonomically designed to provide the ultimate in passenger comfort. The soft pads provide excellent forearm support on a long ride, and eliminate the passenger's "what do I do with my hands" dilemma.

CHANGING YOUR SEAT



Switching out your seat is simple. And because certain rides call for certain styles, some folks like to have multiple seats to match the occasion. Install a comfortable, supportive touring seat for the longer treks and swap it out for a low-profile seat for a night on the town. Please see your owner's manual for proper removal and installation of seats.

TOURING SEAT TYPES

Solo or two-up, comfort or style, check out these seats to get an idea of where you want to sit.



POSITION SEATS

Designed to place the rider in the best relationship to the controls, Reach® and Tallboy® seats position short and tall riders for a comfortable extension of the arms and legs.



TOURING SEATS

Designed for comfort, Sundowner™ and Signature Series® seats offer a broad seating surface to reduce pressure points and a dished shape holds you in place and provides additional back support.



SUSPENSION SEATS

Harley® Hammock and Road Zeppelin® seats provide isolation from road shock with internal fabric or air bladder suspension systems that prevent "bottoming out" to increase rider comfort and endurance.

CUSTOM SEATING PROGRAM

A personalized seat is the perfect thread to tie your bike's attitude together. Select the stitching pattern, leather inlay and thread color that best support your custom movement and you'll have your personalized seat in just three weeks. For more details, turn to page 796 or visit h-d.com/customseat.



TOURING & TRIKE 355

Seating – Low Profile



A. BRAWLER SOLO SEAT

A. BRAWLER® SOLO SEAT

When it's time to go it alone, go solo in style. These premium quality cowhide leather saddles are designed to create a subtle and distinctive look. Top-grain leather seating surface and contoured foam padding add long-haul comfort and the durable hand-laid fiberglass seat pan is carpeted to protect the paint finish. Does not fit with passenger pillions.

51525-09A **\$349.95**

Fits '08-later Touring models. Does not fit Trike models. Does not fit models equipped with Passenger Grab Rails. Does not accept rider backrest. Seat width 13.0".

53373-02A **\$349.95**

Fits '97-'07 Road King® and FLHX models. Does not fit with rider backrest. Seat width 13.0".

B. SIDEKICK® SEAT

Share your custom ride. The two-up design of these premium cowhide leather seats offers a frame-hugging look, but adds back support for the rider and additional padding for the passenger. The custom seating surface and the hand-laid fiberglass seat base show attention to detail second to none.

51526-09A **\$399.95**

Fits '08-later Touring models. Does not fit Trike models. Does not fit models equipped with Passenger Grab Rails. Does not accept rider backrest. Installation on '12-later CVO™ models requires removal of fender trim strips. Seat width 13.5"; passenger pillion width 6.5".

51444-04A **\$399.95**

Fits '97-'07 Road King and FLHX models. Does not fit with rider backrest. Seat width 13.5"; passenger pillion width 6.5".



B. SIDEKICK SEAT

Notice: The prices appearing in this catalog are the manufacturer's suggested retail prices. Actual retail prices may vary.

TOURING

To add custom inlays and stitching to your Brawler® or Sidekick® seat, see pages 796-797, or visit: www.h-d.com/customseat.



356 TOURING & TRIKE

Seating – Low Profile

A. BADLANDER® SEAT

Once again, bad is good. The popular Badlander® Custom Seat is available for your Touring model. Designed to fit your bike like a glove, this seat delivers low-slung cruiser style from rear fender to the tank console. Low and lean, the clean, smooth cover and the embroidered "Harley-Davidson" logo add up to a radical look. Does not accept a rider backrest.

52067-08A **\$299.95**

Fits '08-later Touring models. Does not fit Trike models. Installation on '12-later CVO™ models requires removal of fender trim strips. Seat width 13.0"; passenger pillion width 6.0".

52066-97C **\$299.95**

Fits '97-'07 Road King® (except FLHRS) and FLHX models. Also fits '97-'07 Electra Glide® and Road Glide® models equipped with Fuel Tank Console P/N 71288-03A or Trim Piece P/N 52447-96. Seat width 12.25"; passenger pillion width 4.5".

52265-01A **\$299.95**

Fits '97-'07 Electra Glide (except FLHX) and Road Glide models. Seat width 12.5"; passenger pillion width 4.5".



A. BADLANDER SEAT

B. LOW-PROFILE SOLO TOURING SEAT – MAHOGANY BROWN

Set your custom bagger apart with a Low-Profile Solo Seat that combines street-rod style with a surprising touch of comfort. Start with a shape that distributes your weight across a wide surface area to reduce pressure points. Add a tapered nose that brings the legs closer together to shorten the reach to the ground. Finish it with rich textured mahogany-brown vinyl, upholstered in a custom diamond-pleat pattern with complementing double-row gold stitching. The result is the slammed custom seat that you crave, with enough comfort and support to let you actually spend time in the saddle. Finish the look with your choice of matching passenger pillion, sissy bar pad and Tour-Pak® backrest pad.

52000057 **\$359.95**

Fits '09-later Touring models. Does not fit Trike models. Does not accept Rider Backrest. Seat width 15.0".

Shown with:

LOW-PROFILE PASSENGER PILLION – MAHOGANY BROWN

Bring a passenger along for the ride. Dressed in rich textured brown vinyl and finished with elegant gold stitching, this Passenger Pillion is the perfect complement to the Mahogany Brown Solo Seat. Easy on-and-off installation lets you change from a two-up tourer to a stripped-down cruiser in seconds. Includes matching grab strap.

52400040 **\$274.95**

Fits '09-later Touring models equipped with Solo Seat P/N 52000057. Pillion width 11.0". Does not fit Trike models.



B. LOW-PROFILE SOLO TOURING SEAT – MAHOGANY BROWN (SHOWN WITH LOW-PROFILE PASSENGER PILLION)

C. LEATHER LOW-PROFILE BUCKET SEAT

A custom-look low and slammed seat, with a bucket contour for added support. Features embroidered logo and an opening that receives a matching Rider Backrest.

52095-08A **\$329.95**

Fits '08-later Touring and Tri Glide® models. Installation on '12-later CVO models requires removal of fender trim strips. Seat width 15.0"; passenger pillion width 8.5".

52918-98B **\$329.95**

Fits '97-'07 Road King (except FLHRS) and FLHX models. Also fits '97-'07 Electra Glide and Road Glide models equipped with Fuel Tank Console P/N 71288-03A or Trim Piece P/N 52447-96. Seat width 15.7"; passenger pillion width 6.5".



C. LEATHER LOW-PROFILE BUCKET SEAT

NOTE: Some Harley-Davidson® seats are made of leather. Fine leathers or other natural materials WILL gain "character," such as wrinkles or wear, with age. This is normal. A fine, aged patina and character wrinkles are a sign of the extremely high quality materials used to construct your seat or backrest. The appearance of scars or marks on the leather are a result of using natural leather panels and should not be thought of as an imperfection. Please use Harley-Davidson Leather Dressing P/N 98261-91V to protect your investment.

Notice: The prices appearing in this catalog are the manufacturer's suggested retail prices. Actual retail prices may vary.

TOURING & TRIKE 357

Seating – Low Profile



D. RALLYRUNNER SEAT

D. RALLYRUNNER® SEAT

The Rallyrunner® Seat features thicker padding for the rider and a wider passenger pillion for the passenger. The premium cowhide leather seating surface has a rich, luxurious feel and the carpeted hand-laid fiberglass seat base hugs the fender for a custom look. The foam padding will form to the rider's shape and provide hours of riding comfort.

51527-09A

\$399.95

Fits '08-later Touring models. Does not fit Trike models. Does not fit models equipped with Passenger Grab Rails. Does not accept rider backrest. Installation on '12-later CVO™ models requires removal of fender trim strips. Seat width 13.5"; passenger pillion width 10.0".

E. ROAD ZEPPELIN® AIR ADJUSTABLE SEAT

The mating of comfort and style. Low-profile Road Zeppelin® Seats are equipped with a unique adjustable air bladder system that distributes your weight across the seating surface. The air bladder system removes pressure points and provides shock absorption for the rider's and passenger's tailbone. You get hours of riding comfort, without sacrificing the low-slung custom look. The combination of smooth vinyl and water-resistant textured fabric seating surfaces allows air to circulate beneath the body, reducing the air temperature between the rider and seat. The easy-to-reach integrated hand pumps and air release valves permit quick and convenient adjustment for both the rider and passenger.

52000152

\$599.95

Fits '08-later Touring models. Does not fit Trike models. Does not fit models equipped with Passenger Grab Rails or Rider Backrests. Installation on '12-later CVO models requires removal of fender trim strips. Seat width 15.5", passenger pillion width 12.0".



E. ROAD ZEPPELIN AIR ADJUSTABLE SEAT



E. ROAD ZEPPELIN AIR ADJUSTABLE SEAT

NOTE: Some Harley-Davidson® seats are made of leather. Fine leathers or other natural materials WILL gain "character," such as wrinkles or wear, with age. This is normal. A fine, aged patina and character wrinkles are a sign of the extremely high quality materials used to construct your seat or backrest. The appearance of scars or marks on the leather are a result of using natural leather panels and should not be thought of as an imperfection. Please use Harley-Davidson Leather Dressing P/N 98261-91V to protect your investment.

Notice: The prices appearing in this catalog are the manufacturer's suggested retail prices. Actual retail prices may vary.

358 TOURING & TRIKE

Seating – Short & Tall Rider

REDUCED REACH® SEATS

Designed to position riders with a shorter inseam closer to the ground, Reduced Reach® Seats are shaped to place the rider in a comfortable and confident relationship to the hand and foot controls. The wide seating surface provides loads of support while riding and the narrow tapered nose brings your legs together for an easier reach to the ground at a stop. Reduced Reach Seats feature a stepped profile that provides back support and keeps the rider from sliding back during acceleration.

A. REDUCED REACH SEAT – '09-LATER MODELS

This Reduced Reach forward position seat brings the legs about 1.0" closer together and features enhanced back support padding that moves the rider lower and forward.* Seat can be equipped with optional rider backrest for added support and comfort.

*Measurements based on Original Equipment Electra Glide® seat:

'09 models – 1.0" lower, 2.5" forward

'10-'13 models – .5" lower, 2.5" forward

'14-later models – stock height, 2.0" forward

52000131 **\$349.95**

Fits '14-later Touring and Trike models. Seat width 14.0"; passenger pillion width 13.5".

54383-11 **\$349.95**

Fits '09-'13 Touring and Trike models. Also fits '14-later Touring models not equipped with Tour-Pak®. Installation on '12-later CVO™ models requires removal of fender trim strips. Seat width 13.0"; passenger pillion width 12.0".

B. REDUCED REACH SEAT – '08 MODELS

This Reduced Reach forward position seat brings the legs about 1.0" closer together so that feet rest firmly on the pavement and is shaped to move the rider approximately .5" lower* and .5" forward. Seat can be equipped with optional rider backrest for added support and comfort.

*Measurement based on '08 Electra Glide Original Equipment seat.

52619-08A **\$349.95**

Fits '08 Touring and Trike models. Seat width 15.0"; passenger pillion width 13.0".

C. REDUCED REACH SEAT – '97-'07 MODELS

This Reduced Reach forward position seat has a tapered nose to bring the legs closer together. The bucket-shaped pillow-look saddle features added back support padding that moves the rider approximately 1.5" lower and 1.5" forward. Seat can be equipped with an optional Rider Backrest Kit for added support.

52544-05A **\$349.95**

Fits '97-'07 Electra Glide (except FLHX) and '98-'07 Road Glide® models. Seat width 16.0"; passenger pillion width 13.0".

52609-05 **\$349.95**

Fits '97-'07 Road King® (except FLHRS) and FLHX models. Also fits '97-'07 FLHT and FLTR models equipped with Fuel Tank Console P/N 71288-03A or Trim Piece P/N 52447-96. Seat width 16.0"; passenger pillion width 13.0".



A. REDUCED REACH SEAT – '09-LATER MODELS



B. REDUCED REACH SEAT – '08-LATER MODELS



C. REDUCED REACH SEAT – '97-'07 MODELS

Notice: The prices appearing in this catalog are the manufacturer's suggested retail prices. Actual retail prices may vary.

TOURING & TRIKE 359

Seating – Short & Tall Rider



D. SUPER REDUCED REACH SEAT

D. SUPER REDUCED REACH® SEAT

Get a little bit closer. Super Reduced Reach® forward position seats are designed to move riders with a shorter inseam even closer to the controls and to bring the legs about 1.0" closer together so that your feet rest firmly on the pavement. The scooped bucket-shape saddle is enhanced with added back support padding to move the rider lower and forward.* The combination positions the rider closer to the hand and foot controls to offer both comfort and confidence. Seat can be equipped with optional rider backrest for added support and comfort.

*Measurements based on Original Equipment

Electra Glide® seat:

'09 models – 2.0" lower, 2.5" forward

'10-'13 models – 1.5" lower, 2.5" forward

'14-later models – .5" lower, 2.0" forward

52000132 **\$329.95**

Fits '14-later Touring and Tri Glide® models. Seat width 14.0"; passenger pillion width 13.5".

54382-11 **\$349.95**

Fits '09-'13 Touring and Trike models. Also fits '14-later Touring models not equipped with Tour-Pak®. Installation on '12-later CVO™ models requires removal of fender trim strips. Seat width 13.0"; passenger pillion width 12.0".



E. TALLBOY SEAT – '08-LATER MODELS

TALLBOY® SEATS

The correct riding position can help a tall rider sit comfortably on the bike and avoid leg cramps and back strain during a long day in the saddle. For riders with a longer inseam, a Tallboy® Seat will put you on the road to fatigue-free riding. Designed to move the rider up and back from the stock seating position, a Tallboy Seat can eliminate the "knees-high" riding position and effectively places the body for a natural arm and leg reach to the controls. Tallboy Seats feature a bucket-shaped design for added support and a wide seating surface to reduce pressure on the tailbone.

E. TALLBOY SEAT – '08-LATER MODELS

This Tallboy Seat moves the rider back* to provide much-needed arm and leg room for the long-limbed rider. The seat height is similar to stock and the slight bucket shape offers additional lower back support. Passenger comfort will be maximized with the Tour-Pak Luggage mounted in the rear-most position. Accepts rider backrest (except Adjustable Style) for additional touring comfort.

*Measurements based on Original Equipment

Electra Glide seat:

'08-'13 models – stock height, 2.0" rearward

'14-later models – stock height, 1.5" rearward

52000134 **\$349.95**

Fits '14-later Touring and Tri Glide models. Not compatible with Adjustable Rider Backrest kits or Passenger Grab Rails. Seat width 16.0"; passenger pillion width 14.5".

52099-09A **\$349.95**

Fits '08-'13 Touring and Trike models. Also fits '14-later Touring models not equipped with Tour-Pak. Does not fit models equipped with Adjustable Rider Backrest Kits or Passenger Grab Rails. Installation on '12-later CVO models requires removal of fender trim strips. Seat width 16.0"; passenger pillion width 14.0".

F. TALLBOY SEAT – '97-'07 MODELS

This Tallboy one-piece seat moves the rider back .5" and up 1.25" compared to the Original Equipment seat. The new position allows additional leg and arm movement for the long-limbed rider and a comfortable seating space for the open road. The bucket design of the Tallboy Seat provides additional rider back support and the wide raised pillion places the passenger for maximum comfort and commanding view. Can also be used with Rider Backrest Kits.

52975-05 **\$349.95**

Fits '97-'07 Electra Glide (except FLHX) and Road Glide® models. Seat width 17.5"; passenger pillion width 15.0".

52976-05 **\$349.95**

Fits '97-'07 Road King® and FLHX models. Also fits '97-'07 Electra Glide and Road Glide models equipped with Fuel Tank Console P/N 71288-03A or Trim Piece P/N 52447-96. Seat width 17.0"; passenger pillion width 16.0".



F. TALLBOY SEAT – '97-'07 MODELS

360 TOURING & TRIKE

Seating – Sundowner™

SUNDOWNER™ SEATS

The Sundowner™ Seat provides the maximum in long-riding comfort. The deep-bucket design puts your body in the proper touring position and the generous padding makes it comfortable for both the rider and passenger as the miles are adding up. The dished shape back provides added rider back support and the wide passenger pillion is shaped to minimize pressure points.

A. SUNDOWNER SEAT – SMOOTH

The smooth cover complements any Touring model. Seat accepts rider backrest for additional touring comfort.

52000128 **\$349.95**
Fits '14-later Touring and Tri Glide® models. Seat width 14.5"; passenger pillion width 13.0".

52093-08A **\$349.95**
Fits '08-'13 Touring and Trike models. Also fits '14-later Touring models not equipped with Tour-Pak®. Installation on '12-later CVO™ models requires removal of fender trim strips. Seat width 16.0"; passenger pillion width 14.0".

51726-05 **\$349.95**
Fits '97-'07 Road King® and FLHX models. Also fits '97-'07 Electra Glide® and Road Glide® models equipped with Fuel Tank Console P/N 71288-03A or Trim Piece P/N 52447-96. Seat width 15.0"; passenger pillion width 12.0".

51542-01B **\$349.95**
Fits '97-'07 Electra Glide (except FLHX) and Road Glide models. Seat width 16.0"; passenger pillion width 13.5".

B. SUNDOWNER SEAT – FREEWHEELER™

This Sundowner seat is finished in rich black vinyl and is styled to complement the Freewheeler™ Trike model's Original Equipment seat.

52000183 **\$349.95**
Fits '15-later FLRT models. Seat width 15.0"; passenger pillion width 11.0".

C. SUNDOWNER SEAT – ROAD KING® CLASSIC BASKETWEAVE

Decorated with pleated leather valance and chrome Road King Classic concho, the seat stays true to Road King Classic styling. Accepts rider backrest for additional touring comfort.

51615-09A **\$379.95**
Fits '08-'13 Touring and Trike models. Also fits '14-later Touring models not equipped with Tour-Pak. Installation on '12-later CVO models requires removal of fender trim strips. Seat width 16.0"; passenger pillion width 14.0".

51615-99C **\$379.95**
Fits '97-'07 Road King and FLHX models. Also fits '97-'07 Electra Glide and Road Glide models equipped with Fuel Tank Console P/N 71288-03A or Trim Piece P/N 52447-96. Seat width 15.0"; passenger pillion width 12.0".



A. SUNDOWNER SEAT – SMOOTH
(52000128 SHOWN)



B. SUNDOWNER SEAT – FREEWHEELER



C. SUNDOWNER SEAT – ROAD KING CLASSIC BASKETWEAVE
(51615-09A SHOWN)

Notice: The prices appearing in this catalog are the manufacturer's suggested retail prices. Actual retail prices may vary.

TOURING & TRIKE 361

Seating – Sundowner™



**D. SUNDOWNER SEAT – '06-'10 STREET GLIDE STITCHING
(51630-09A SHOWN)**

**D. SUNDOWNER™ SEAT – '06-'10 STREET GLIDE®
STITCHING**

Decorated with "tuck and roll" pleating, the Sundowner™ Seat complements the '06-'10 Street Glide® styling. Accepts rider backrest for additional touring comfort.

51630-09A \$369.95

Fits '08-'13 Touring and Trike models. Also fits '14-later Touring models not equipped with Tour-Pak®. Installation on '12-later CVO™ models requires removal of fender trim strips. Seat width 16.0"; passenger pillion width 14.0".

51630-06 \$379.95

Fits '97-'07 FLHX and Road King® models. Also fits '97-'07 Electra Glide® and Road Glide® models equipped with Fuel Tank Console P/N 71288-03A or Trim Piece P/N 52447-96. Seat width 15.0"; passenger pillion width 12.0".

E. SUNDOWNER SEAT – ROAD KING® BLACK STUDS

Decorated with black studs and the embroidered Road King V-logo, the seat stays true to Road King styling. Accepts rider backrest as well for additional touring comfort.

51617-99C \$379.95

Fits '97-'07 Road King and FLHX models. Also fits '97-'07 Electra Glide and Road Glide models equipped with Fuel Tank Console P/N 71288-03A or Trim Piece P/N 52447-96. Seat width 15.0"; passenger pillion width 12.0".

**F. SUNDOWNER SEAT – ROAD KING CUSTOM
STITCHING**

Decorated with complementing stitching, the Sundowner Seat holds true to the Road King Custom styling. Accepts rider backrest for additional touring comfort.

51093-04A \$379.95

Fits '97-'07 Road King and FLHX models. Also fits '97-'07 Electra Glide and Road Glide models equipped with Fuel Tank Console P/N 71288-03A or Trim Piece P/N 52447-96. Seat width 15.0"; passenger pillion width 12.0".



**E. SUNDOWNER SEAT – ROAD KING BLACK STUDS
(SHOWN WITH ROAD KING PASSENGER BACKREST PAD)**



**F. SUNDOWNER SEAT – ROAD KING CUSTOM STITCHING
(SHOWN WITH RIDER BACKREST KIT AND PASSENGER BACKREST PAD)**

TOURING

Notice: The prices appearing in this catalog are the manufacturer's suggested retail prices. Actual retail prices may vary.

362 TOURING & TRIKE

Seating – Sundowner™

A. SUNDOWNER™ SOLO SEAT

Only one can sit on the throne. This unique seat combines the deep bucket design and added back support of the two-up Sundowner™ Seat with the stripped-down look of a solo saddle. Same great comfort as the popular two-up version, but in a solo. Matching passenger pillion is available for added versatility.

Fits '97-'07 Road King® (except FLHRS) and FLHX models. Also fits '97-'07 Electra Glide® and Road Glide® models equipped with Fuel Tank Console P/N 71288-03A or Trim Piece P/N 52447-96. All models (except FLHR) require separate purchase of Solo Seat Hardware Kit P/N 52903-01. Does not accept rider backrest. Seat width 16.0".

51928-01 Smooth. **\$299.95**

51092-04 Road King Classic. **\$319.95**

Shown with:

SUNDOWNER PASSENGER PILLION – SMOOTH

This sculpted pillion provides your passenger with the same cushioned comfort as your Solo Sundowner Seat.

51929-01 **\$179.95**

Fits '97-'04 Touring models equipped with an Original Equipment or accessory solo seat (except Brawler® Solo seats). Passenger pillion width 12.5".



A. SUNDOWNER SOLO SEAT – SMOOTH (SHOWN WITH SUNDOWNER PASSENGER PILLION)



A. SUNDOWNER SOLO SEAT – ROAD KING CLASSIC BASKETWEAVE

B. SIGNATURE SERIES® SOLO SEAT WITH RIDER BACKREST

The perfect combination of foam density and shape has resulted in our most comfortable seat for long-haul touring. The seat is shaped with a wide seating area to spread the pressure across the broad surface and a narrow nose area to keep your legs together for a shorter reach to the ground. The Signature Series® Solo Seat features a built-in, fully adjustable and removable rider backrest for added support. The backrest provides a 5-position height adjustment with 1.5" range and a wide range of forward/back adjustment with a quick twist of the control knob. The backrest pad features a sleek shape that provides full lower back support without pushing the rider forward. When combined with the comfortable Passenger Pillion P/N 52000133 or 51770-09 (sold separately), the slim profile of the rider backrest offers the passenger a few more inches of space and the fold-down design permits easy passenger mounting/dismounting. The rich vinyl seating surface is easy to clean and maintain and features an embossed Bar & Shield logo on the side skirts for a finishing touch.

51700-09 **\$529.95**

Fits '08-later Touring models. Seat width 16.5".



B. SIGNATURE SERIES SOLO SEAT WITH RIDER BACKREST

C. SIGNATURE SERIES PASSENGER PILLION

This easy-to-install pillion is designed for long range passenger comfort. The wide seating surface and specific-density padding reduce pressure points and spread the weight for superior support. The smooth cover matches the Signature Series Solo Seat and the embossed Bar & Shield logo on the rear shows everyone that you are riding in style. Add a matching Smooth Passenger Backrest for the complete look.

52000133 **\$169.95**

Fits '14-later Touring models. Passenger pillion width 15.0".

51770-09 **\$169.95**

Fits '08-'13 Touring models equipped with Solo Seat P/N 51700-09. Also fits '14-later Touring models not equipped with Tour-Pak®. Installation on '12-later CVO™ models requires removal of fender trim strips. Passenger Pillion width 15.0".



C. SIGNATURE SERIES PASSENGER PILLION

Notice: The prices appearing in this catalog are the manufacturer's suggested retail prices. Actual retail prices may vary.

TOURING & TRIKE 363

Seating – Sun Ray®



D. SUN RAY HEATED SEAT – '14-LATER MODELS

D. SUN RAY® HEATED SEAT – '08-LATER MODELS

Chase away the chill on long fall and winter rides. This second generation heated seat features dual-zone heated rider and passenger positions with separate high/low/off toggle controls for personal comfort selection. The one-piece seat with integrated heat pad and control system is simple to install and the heating element is switched on/off with the ignition to avoid draining the battery. Smooth styling complements any Touring model. Can be used with optional Rider Backrest Kits.

52000135 Vinyl. **\$824.95**

Fits '14-later Touring and Tri Glide® models. Separate purchase of Electrical Harness Extension P/N 69200722 is required. Seat width 15.0"; passenger pillion width 15.0".

52633-08A Vinyl. **\$824.95**

Fits '08-'13 Touring and Trike models. Also fits '14-later Touring models not equipped with Tour-Pak®. '14-later Touring models require the separate purchase of Electrical Harness Extension P/N 69200722. Installation on '12-later CVO™ models requires removal of fender trim strips. Seat width 15.0"; passenger pillion width 15.0".

E. SUN RAY HEATED SEAT – '97-'07 MODELS

Chase away the chill on long fall and winter rides. This Sun Ray® Heated Seat features dual-zone heated rider and passenger positions with separate high/low/off toggle controls for personal comfort selection. The durable leather seating surface with embossed ostrich skin pattern covers a deep bucket rider seat and a supportive passenger pillion for cross-country comfort. The one-piece seat with integrated heat pad and control system is simple to install and the heating element is switched on/off with the ignition to avoid draining the battery. Can be used with Rider Backrest Kits.

51718-06 Leather. **\$999.95**

Fits '97-'07 Electra Glide® (except FLHX) and '98-'07 Road Glide® models. Seat width 17.0"; passenger pillion width 16.0".



D. SUN RAY HEATED SEAT – '08-'13 MODELS



E. SUN RAY HEATED SEAT – '97-'07 MODELS

Notice: The prices appearing in this catalog are the manufacturer's suggested retail prices. Actual retail prices may vary.

364 TOURING & TRIKE

Seating – Harley® Hammock

A. HARLEY® HAMMOCK RIDER AND PASSENGER TOURING SEAT

Protect the backside of both rider and passenger from harsh road conditions. With its revolutionary suspension systems, this Harley® Hammock Rider and Passenger Touring Seat offers increased isolation from sharp road impacts. For the rider, sling-like fabric suspension system acts like a hammock to reduce impacts and the two inches of traditional foam on top provides additional support. For the passenger, a multiple spring-board style suspension system along with two inches of traditional foam provides 15% improvement in passenger comfort. The generous seat length accommodates a wide variety of rider sizes and allows fore-and-aft movement to vary the position on a long ride. Available with or without dual-zone heated rider and passenger seating areas, this seat's vinyl surface is easy to clean and maintain. Can be equipped with Rider Backrest (sold separately) on most models.

52000177 With Heat. **\$899.95**
Fits '14-later Touring and Tri Glide® models. Separate purchase of Electrical Harness Extension P/N 69200722 is required. Seat width 17.0"; passenger pillion width 15.0".

52000176 Without Heat. **\$549.95**
Fits '14-later Touring and Tri Glide models. Seat width 17.0"; passenger pillion width 15.0".

52000004A With Heat. **\$899.95**
Fits '09-'13 Touring and Trike models. Also fits '14-later Touring models not equipped with Tour-Pak®. '14-later Touring vehicles require the separate purchase of Electrical Harness Extension P/N 69200722. Trike models require separate purchase of Paint Guard Kit P/N 52000013. Does not fit models equipped with Passenger Grab Rail. Installation on '12-later CVO™ models requires removal of fender trim strips. Seat width 17.5"; passenger pillion width 15.0".

52000003A Without Heat. **\$549.95**
Fits '09-'13 Touring and Trike models. Also fits '14-later Touring models not equipped with Tour-Pak. Trike models require separate purchase of Paint Guard Kit P/N 52000013. Does not fit models equipped with Passenger Grab Rail. Installation on '12-later CVO models requires removal of fender trim strips. Seat width 17.5"; passenger pillion width 15.0".

52000072 Without Heat. **\$549.95**
Fits '97-'07 Electra Glide® and Road Glide® models. Seat width 18.0"; passenger pillion width 15.5".

52000075 Without Heat. **\$549.95**
Fits '97-'07 Road King® and FLHX models. Seat width 18.0"; passenger pillion width 15.5".

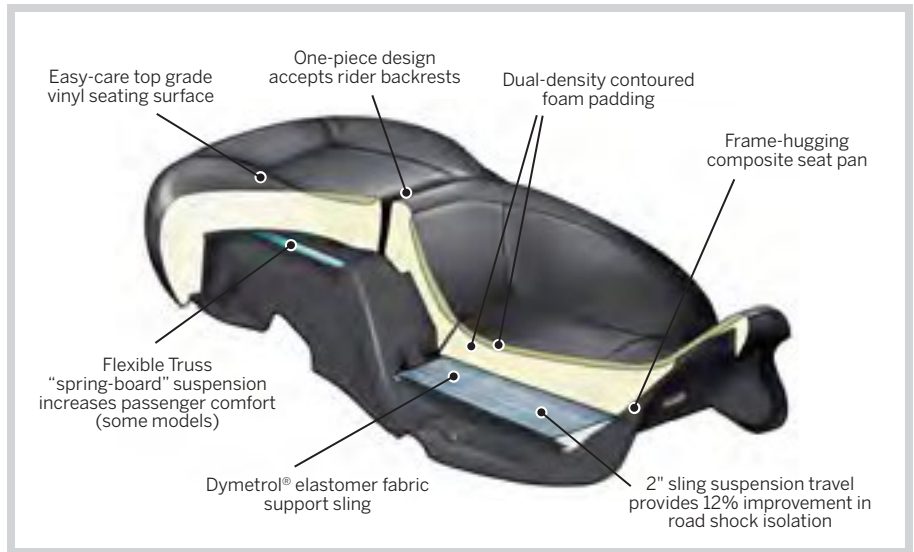

A. HARLEY HAMMOCK RIDER AND PASSENGER TOURING SEAT



A. HARLEY HAMMOCK RIDER AND PASSENGER TOURING SEAT
'14-LATER MODELS



A. HARLEY HAMMOCK RIDER AND PASSENGER TOURING SEAT
'97-'13 MODELS

Notice: The prices appearing in this catalog are the manufacturer's suggested retail prices. Actual retail prices may vary.

TOURING & TRIKE 365

Seating – Harley® Hammock

B. HARLEY® HAMMOCK RIDER TOURING SEAT

This Harley® Hammock Seat coddles the rider and supports their weight with a wide seating surface and the revolutionary sling-like fabric suspension system. The passenger rides on a generous pillion of dual-density foam, shaped for support and long-haul comfort. The Harley Hammock Seat's vinyl surface is easy to clean and maintain and is finished with a "Harley-Davidson" raised script logo. Can be equipped with Rider Backrest (sold separately) on most models.

53051-09 **\$549.95**

Fits '08 Touring models equipped with Tour-Pak® luggage. Does not fit models equipped with Passenger Grab Rail. Installation on '12-later CVO™ models requires removal of fender trim strips. Seat width 17.5"; passenger pillion width 15.0".

C. COMFORT STITCH SEAT

The deep bucket seat design and the smooth cover and stitching are the perfect complement to the Road King® style. The deep pocket provides additional back and thigh support for long distance comfort. Can be used with Rider Backrest Kits.

51157-04A **\$349.95**

Fits '97-'07 Road King and FLHX models. Also fits '97-'07 Electra Glide® and Road Glide® models equipped with Fuel Tank Console P/N 71288-03A or Trim Piece P/N 52447-96. Seat width 17.0"; passenger pillion width 16.0".

51703-05 **\$349.95**

Fits '97-'07 Electra Glide (except FLHX) and Road Glide models. Seat width 17.0"; passenger pillion width 16.0".

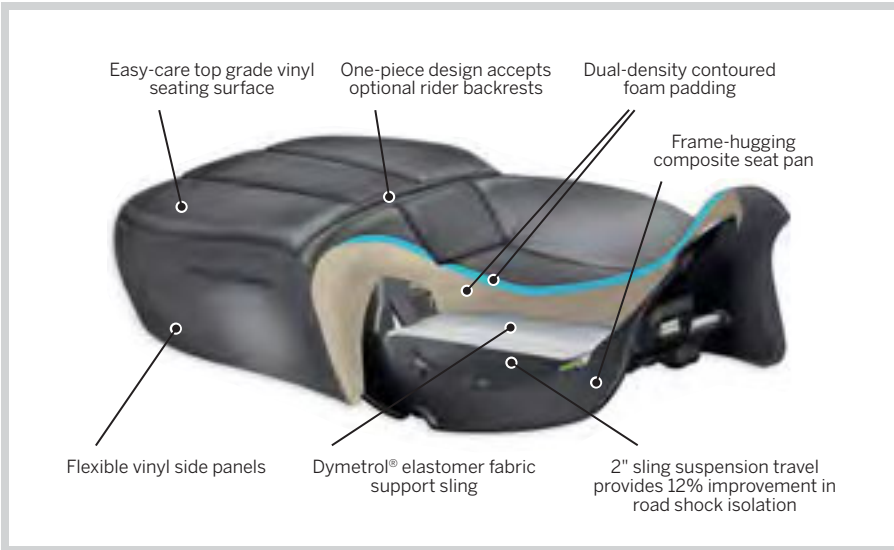

B. HARLEY HAMMOCK RIDER TOURING SEAT



**B. HARLEY HAMMOCK RIDER TOURING SEAT
'08 MODELS**



**C. COMFORT STITCH SEAT FOR ROAD KING MODELS
(SHOWN WITH COMFORT STITCH ADJUSTABLE RIDER BACKREST)**

TOURING

Notice: The prices appearing in this catalog are the manufacturer's suggested retail prices. Actual retail prices may vary.

366 TOURING & TRIKE

Seating – Road Zeppelin®

ROAD ZEPPELIN® AIR ADJUSTABLE SEATS

The open road. That's where we developed and tested the revolutionary comfort of the Road Zeppelin® Seat. This remarkable seat removes pressure points and "hot spots" by adjusting the amount of air contained in each bladder within the seat. Easy-to-reach rocker switches on the side of the seat control the built-in compressor, adding and bleeding off air with the quick push of a button to help relieve stress from the lower back, tail-bone or lower extremities. On a long run, occasionally inflating and deflating the air bladders reduces the "numb butt" effect by improving the blood flow to the extremities. So grab a seat. And enjoy the ride.

A. ROAD ZEPPELIN AIR ADJUSTABLE SEAT – '08-LATER MODELS

This Road Zeppelin Seat features two adjustment zones for the rider and one for the passenger and an internal air compressor that adjusts the air level nearly twice as fast as the previous version. The ergonomically-friendly seat design features a narrow front nose for ease of touching the ground at a stop, with a wide seating surface for long range rider and passenger comfort. This seat is a great addition to Trike models too. The easy-to-clean vinyl seat is finished with an embroidered Road Zeppelin logo that lets everyone see that you take riding comfort seriously. This easy-to-install seat accepts a rider backrest and passenger grab rail for additional touring comfort.

51072-09 Comfort Stitch. **\$739.95**
Fits '08-'13 Touring and '09-later Tri Glide® models. '14-later models requires the separate purchase of Electrical Harness Extension P/N 69200722. Installation on '12-'13 CVO™ models requires removal of fender trim strips. Seat width 20.0"; passenger pillion width 14.5".

Passenger Zone

Press the 3rd button to inflate and deflate the passenger area, providing maximum comfort to the backbone and support to the thigh area.

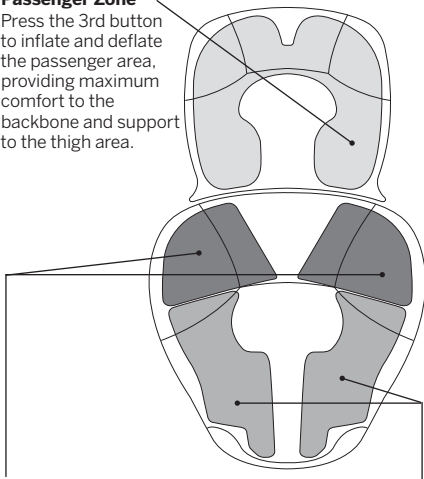

Lower Back Zones

Press the 2nd button (rider only) to adjust the support in the lower back zone chambers, relieving pressure points in the lower back.

Thigh Zones

Press the 1st button to adjust pressure in the two thigh zone chambers, improving blood flow to lower extremities and adding support to thighs.

'08-LATER MODELS



A. ROAD ZEPPELIN AIR ADJUSTABLE SEAT – '08-LATER MODELS



A. ROAD ZEPPELIN AIR ADJUSTABLE SEAT – CONTROL PANEL

Notice: The prices appearing in this catalog are the manufacturer's suggested retail prices. Actual retail prices may vary.

TOURING & TRIKE 367

Seating – Road Zeppelin®



**B. ROAD ZEPPELIN AIR ADJUSTABLE SEAT – LEATHER – '97-'07 MODELS
(SHOWN WITH RIDER AND PASSENGER BACKREST)**

B. ROAD ZEPPELIN® AIR ADJUSTABLE SEAT – LEATHER – '97-'07 MODELS

This premium seat features leather seating surfaces for long-distance touring comfort. Kit includes protective rain cover.

52333-97E Leather. **\$939.95**

Fits '97-'07 Electra Glide® (except FLHX) and Road Glide® models. Seat width 21.0"; passenger pillion width 17.0".

Shown with:

ROAD ZEPPELIN PASSENGER BACKREST FOR KING TOUR-PAK®

52335-97A **\$299.95**

Fits '97-'13 Touring and Trike models equipped with King Tour-Pak® luggage.

Tailbone Zones

Press the 2nd button to inflate and deflate the tailbone chamber, providing maximum comfort to the backbone.

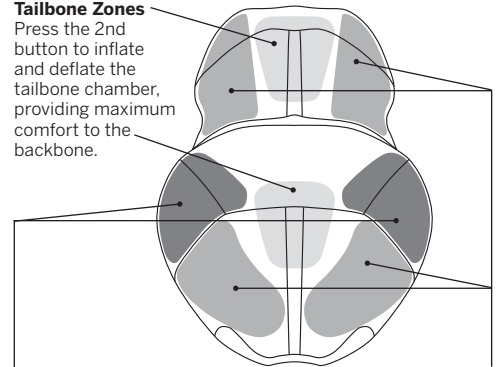

Lower Back Zones

Press the 3rd button (rider only) to adjust the support in the lower back zone chambers, relieving pressure points in the lower back.

Thigh Zones

Press the 1st button to adjust pressure in the two thigh zone chambers, improving blood flow through the lower extremities.

'97-'07 MODELS

C. ROAD ZEPPELIN SEAT PAD

Experience ultimate comfort. Road Zeppelin® Seat Pads are equipped with a unique air bladder system that allows your weight to be distributed evenly across the entire seating surface, ensuring hours of comfort for both rider and passenger. The air bladder system is designed to remove pressure points and provide shock absorption to reduce vibration. The mesh cover allows air to circulate beneath the rider's body, reducing the air temperature between the rider and seat. The easy-to-reach integrated hand pump and air release valve permits quick and convenient adjustment. Shaped to conform to most Harley-Davidson® seats, the pads feature an adjustable mounting strap and a non-skid surface to keep them in place.

52000084 Rider. **\$129.95**

Fits rider position on all models equipped with Original Equipment or accessory seats. Also fits passenger position on Touring models with large pillion area. Pad width – 14.0".

52400060 Passenger Pillion. **\$129.95**

Fits Original Equipment and accessory passenger pillions. Pad length – 11.0"; width – 8.0".



C. ROAD ZEPPELIN SEAT PAD

TOURING

Notice: The prices appearing in this catalog are the manufacturer's suggested retail prices. Actual retail prices may vary.

368 TOURING & TRIKE

Seating – Rider Backrests

A. ADJUSTABLE RIDER BACKRESTS

Add support for the long haul. With one quick pull from the integrated gas spring, you can instantly adjust the riding position through a 30-degree range. The backrest pad features a sleek shape that provides full lower back support without pushing the rider forward and a slim profile that offers the passenger a few more inches of space. The backrest features a pull knob-activated, five-position, 1.5" height adjustment. The backrest can be easily removed and folds down to allow easier passenger mounting.

Fits '97-later Touring and Tri Glide® models equipped with many one-piece slotted seats. This rider backrest may not look appropriate on select Original Equipment, CVO™ and accessory seats that are styled with a low-profile look. Installation requires separate purchase of model-specific Adjustable Rider Backrest Mounting Kit.

1. 52423-09A	Comfort Stitch Style.	\$109.95
2. 52591-09A	Road King® Classic Style.	\$109.95
3. 52546-09A	'06-'10 Street Glide® Style.	\$109.95
4. 52501-09A	Smooth Style.	\$109.95

Shown with:

ADJUSTABLE RIDER BACKREST MOUNTING KIT

Kit includes mounting bracket, adjustment handle and all required installation hardware.

52596-09A **\$219.95**
Required to install Adjustable Rider Backrest on '09-later Touring models. Does not fit Trike models.

54099-10 **\$219.95**
Required to install Adjustable Rider Backrest on '09-later Tri Glide models.

52593-09A **\$219.95**
Required to install Adjustable Rider Backrest on '97-'08 Touring models.



Pull knob in the center of backrest pad to adjust vertically to five different heights.

Push tab on side of frame to adjust angle of backrest pad 30° forward or backward.

A. ADJUSTABLE RIDER BACKREST KITS



A. ADJUSTABLE RIDER BACKRESTS (SHOWN WITH MOUNTING KIT)

Notice: The prices appearing in this catalog are the manufacturer's suggested retail prices. Actual retail prices may vary.

TOURING & TRIKE 369

Seating – Rider Backrests

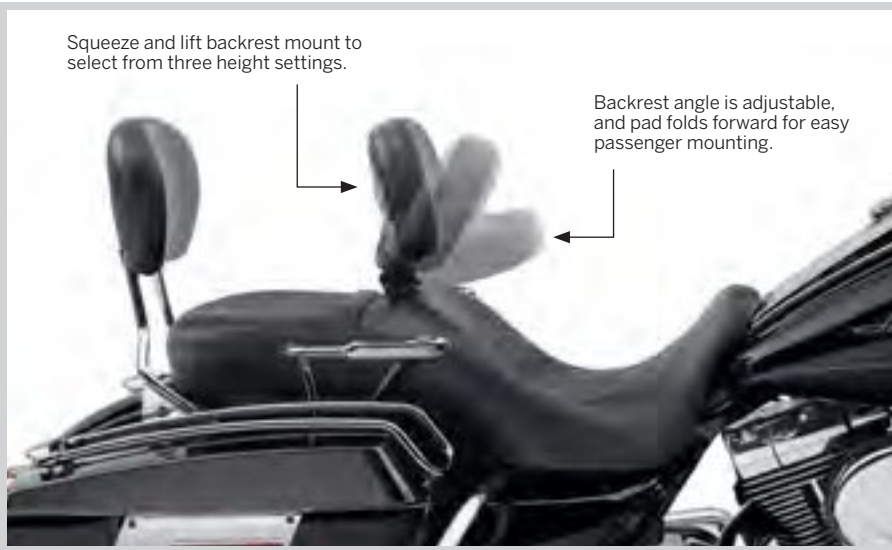

B. RIDER BACKREST

B. RIDER BACKRESTS

Add back support for long-haul riding comfort. Contoured backrest pad is shaped to provide full lower back support without pushing the rider forward and the slim profile offers the passenger a few more inches of room. An adjustable support bracket with four mounting locations accommodates different seats and riding positions. The backrest pad angle can be adjusted for maximum comfort.

Fits '88-later Touring models equipped with one-piece slotted seat. Does not fit Trike models. Installation requires separate purchase of model-specific Rider Backrest Mounting Kit.

1. 52572-09A	Comfort Stitch Style.	\$199.95
2. 52583-09A	Road King® Classic Style.	\$199.95
3. 51631-09A	'06-'10 Street Glide® Style.	\$199.95
4. 52900-09A	Smooth Leather Style.	\$219.95
5. 52914-09A	Smooth Vinyl Style.	\$199.95
6. 52300008	'11 CVO™ Street Glide Style.	\$259.95

Shown with:

RIDER BACKREST MOUNTING KIT

Kit includes mounting bracket and all required installation hardware.

52589-09A **\$44.95**

Required to install rider backrest on '09-later Touring models. Does not fit Trike models.

52587-09 **\$44.95**

Required to install rider backrest on '88-'08 Touring models.



B. RIDER BACKRESTS (SHOWN WITH MOUNTING KIT)

370 TOURING & TRIKE

Seating – Accessories

A. CIRCULATOR SEAT AND BACKREST PADS

Keep comfortable on your next long ride. These breathable Circulator Seat and Backrest Pads feature 3-D construction that promotes air movement and reduces heat build-up where the rider's body touches the seat or backrest. Designed to keep the rider cool by reducing the perspiration build-up between you and the seating surface, the Circulator Pad can be installed and removed in seconds for easy cleaning. The low-profile design minimizes seat-height change compared to inflatable pads, while enhancing comfort with its shock-absorbing construction. Manufactured of UV-stable materials, these seat and backrest pads resist fading when exposed to the sun. Elastic under-seat strap and non-slip base provide secure installation and the available Circulator Passenger Pillion Pad attaches to the rider pad with hook-and-loop tabs.

51076-10 Large Seat Pad. **\$89.95**
Fits Softail® and Touring models with Original Equipment and accessory seats. Will not fit Spring seats and Road Zeppelin® seats. 16.0" wide.

51078-10 Passenger Pillion Pad. **\$69.95**
Fits Original Equipment and accessory passenger pillions. 13.0" wide.

52300103 Wide Backrest Pad. **\$59.95**
Fits wide profile Rider and Passenger Backrest Pads up to 12.0" wide and 9.0" tall.

52300105 Tour-Pak® Wrap Around Backrest. **\$69.95**
Fits Tour-Pak Wrap Around Passenger Backrest Pads.



A. CIRCULATOR SEAT PADS (ROAD KING SHOWN)

B. RAIN COVERS*

Featuring a handy storage sack, this black nylon, water-resistant, Cordura® cover packs easily and shelters your seat from the storm.

51638-97 Solo Seat. **\$29.95**
Fits H-D® solo seats (except XR and FLSTS).

51639-97 Touring Seat. **\$31.95**
Fits FLSTC, FLSTS and most Touring seats. Does not fit with rider or passenger backrests.

51637-97 Two-Up Seat. **\$31.95**
Fits H-D two-up seats (except XR, FLSTC, FLSTS or seats with rider backrests).

52952-97 Seat with Rider Backrest. **\$39.95**
Fits most seats with rider backrest. Does not fit Trike models.



A. CIRCULATOR BACKREST PAD – WIDE



A. CIRCULATOR BACKREST PAD – WRAP AROUND



B. RAIN COVER – SOLO SEAT



B. RAIN COVER – TOURING SEAT

Notice: The prices appearing in this catalog are the manufacturer's suggested retail prices. Actual retail prices may vary.

TOURING & TRIKE 371

Seating – Accessories



C. TOUR-PAK PASSENGER ARMRESTS
(52400074 SHOWN)

C. TOUR-PAK® PASSENGER ARMRESTS

If your passenger is happy, you'll be happy. Premium passenger armrests have been ergonomically designed to provide the ultimate in passenger comfort. The soft pads provide excellent forearm support on a long ride and eliminate the passenger's "what do I do with my hands" dilemma. Both armrests conveniently swing out of the way for easy mounting and dismounting and the pads and arms can be oriented in multiple positions for increased comfort. The armrest pads feature spring-loaded hinged storage compartments that can easily hold your compact personal items. The high-quality black vinyl upholstered pads and support arms blend beautifully with Original Equipment seats and speaker pods. Complete kit includes all required installation hardware.

52400073 **\$399.95**

Fits '14-later Touring models equipped with Hard Tour-Pak® luggage (except CVO™ models). Also fits with H-D® Detachables™ Tour-Pak Mounting Racks. Does not fit Trike models.

52400074 **\$399.95**

Fits '09-'13 Touring models equipped with Hard Tour-Pak Luggage (except CVO models). Also fits with H-D Detachables Tour-Pak Mounting racks. Does not fit Trike models. Does not fit models equipped with Ultra Boom!™ Bagger Kit P/N 76000051 or Boom! Audio Amplifier Kit P/N 76000068.



C. TOUR-PAK PASSENGER ARMRESTS
(52400073 SHOWN)



C. PASSENGER ARMRESTS –
RETRACTED



C. PASSENGER ARMRESTS –
STORAGE COMPARTMENT

D. FLHT/FLTR TRIM PIECE

This top-stitched trim piece opens a new world to the Standard Electra Glide® and Road Glide® model owners, allowing fitment of Road King® seats.

52447-96 Fits '94-'07 FLHT and FLTR models. **\$29.95**

E. TANK BRA

Manufactured from non-abrasive, fleece-backed vinyl, this Tank Bra for your Touring model features an embroidered Bar & Shield logo. It protects your fuel tank from belt buckle and key scratches and nicks from road debris. Designed for easy installation and a custom fit without tank or seat removal.

62063-01 **\$44.95**

Fits '97-later Touring and Trike models.



D. FLHT/FLTR TRIM PIECE



E. TANK BRA

TOURING

Notice: The prices appearing in this catalog are the manufacturer's suggested retail prices. Actual retail prices may vary.

372 TOURING & TRIKE

Seating – Accessories

A. PASSENGER GRAB RAIL

Add comfort and confidence for your riding companion. This easy-to-install handrail provides a convenient hand grip for your passenger and a secure tie-down point for pillion-mounted touring luggage.

Fits '14-later Touring and Tri Glide® models. Does not fit models equipped with Harley® Hammock or Tallboy® Seats.

52400090 Chrome. **\$129.95**

52400091 Gloss Black. **\$129.95**

Fits '09-'13 Touring models. Does not fit Trike models. Does not fit models equipped with Harley Hammock or Tallboy Seats.

97026-09 Chrome. **\$129.95**

Fits '10-'11 FLHXXX, '06-'08 Electra Glide®, Street Glide®, Road King® and Road Glide® models. Does not fit Touring models with Tour-Pak® mounted rear speakers or models equipped with Leather Saddlebags or Harley Hammock Seats. Original Equipment on '09-'13 FLHTCUTG, '99-'05 FLHT, FLHTC and FLHTCU models.

91583-99 Chrome. **\$129.95**

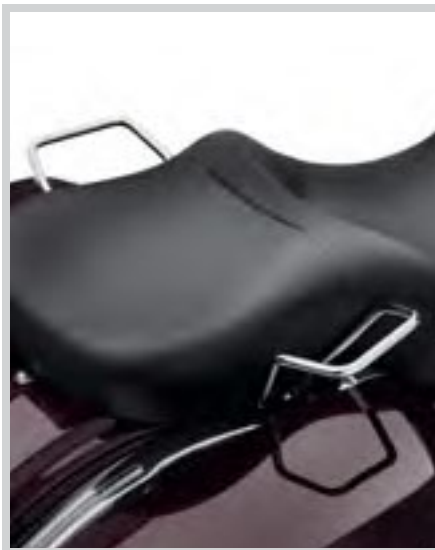

A. PASSENGER GRAB RAIL – CHROME
(52400090 SHOWN)



A. PASSENGER GRAB RAIL – GLOSS BLACK
(52400091 SHOWN)

B. PASSENGER HANDRAIL COVERS

Beef up the look of the passenger handrail with these easy-to-install chrome-plated grips. The thick diameter offers a firm and comfortable hand hold for your passenger and features jet black rubber inserts, "ball-milled" grooves and Bar & Shield logo for added style. Kit includes right and left grip and stainless steel mounting hardware.

91668-05 **\$64.95**

Fits '99-'13 Touring models equipped with Passenger Grab Rails.



A. PASSENGER GRAB RAIL
('09-'13 SHOWN)



B. PASSENGER HANDRAIL COVERS

C. BILLET SEAT MOUNTING BRACKET – CHROME

The highly stylized design of this bracket adds a stunning new look to the back of most seats.

51804-02 **\$19.95**

Replaces Bolt-On Seat Brackets P/N 51798-00, 51740-10, 52467-00, 51652-97A and 51652-83B used on most Original Equipment and accessory seats and pillions.



C. BILLET SEAT MOUNTING BRACKET – CHROME

D. QUICK-RELEASE SEAT HARDWARE KIT

These hardware kits allow the rider to remove one-piece Harley-Davidson® seats quickly and easily.

51676-97A **\$19.95**

Fits '97-later XG, XL, Dyna®, Softail® (except FLS models equipped with Original Equipment seat), Touring and Trike models. Does not fit seats equipped with spring-loaded rear seat bracket.



D. QUICK-RELEASE SEAT HARDWARE KIT

Notice: The prices appearing in this catalog are the manufacturer's suggested retail prices. Actual retail prices may vary.

COMFORT ON THE GO

Sometimes you need more than your bike to make it a great ride. Tour-Pak® luggage holds plenty of rain gear, extra clothing and basic supplies, while a detachable backrest means a passenger can take on the road with you.

THE RIGHT COMBINATION



PUTTING IT TOGETHER

A detachable sissy bar upright and backrest pad is the starting point for a complete touring machine. Start by shopping the following pages and selecting all the components required for your particular model.

EQUIPPED FOR THE MILES AHEAD

Solo and stripped down, two-up and fully loaded or anywhere in between, you can tailor any Harley-Davidson® motorcycle to meet the demands of the highway.



TWO-UP

Take a day's ride on a bike built for two. Saddlebags carry clothes and the essentials, while a Sissy Bar Backrest provides hours of passenger comfort on the open road.



TWO-UP TOUR-PAK® LUGGAGE

The ultimate road trip. With all this space and comfort, you and one lucky passenger are fully equipped to go wherever you want, for as long as you want. See you later.



SOLO TOUR-PAK LUGGAGE

Ride like you're on a mission. The saddlebags and Tour-Pak offer tons of storage space and the Solo Mounting Rack positions the Tour-Pak Pad for maximum rider back support.

LOAD IT UP



Rain gear, extra clothing and basic supplies are easy to take along when you add luggage to your bike. Designed for maximum versatility, this complete collection of sissy bar- and luggage rack-mounted soft touring luggage ensures you will pack what you need for your next trip.

Designed by riders, for riders, the Premium Luggage Collection is formed of superior heavy-weight ballistic nylon to maintain their shape and protect your belongings over the long haul. And the secure spandex mounting system slips over the passenger backrest for a snug fit.

CHANGING YOUR BACKREST



With a Docking Hardware Kit installed, adding or removing a detachable accessory is a simple "slide and click" proposition. Rotate the cam-lock to release the sissy bar from the rear docking points. Pivot the sissy bar forward and lift it free from the front docking points.

374 TOURING & TRIKE

Backrests & Racks

A. 4-POINT DOCKING HARDWARE KIT

The ideal choice for maximum versatility, this complete kit contains the docking hardware necessary to install all H-D® Detachables™ accessory options. Even if you only install a passenger backrest today, this kit allows you to add additional accessories as your touring demands change. Provides docking points to allow installation of H-D Detachables Sissy Bar, Solo Luggage Rack, Two-Up Luggage Rack, Solo Tour-Pak® Rack or Two-Up Tour-Pak Rack.

Fits '14-later Touring models (except models equipped with rigid-mount Tour-Pak luggage).

52300353	Chrome.	\$159.95
52300354	Gloss Black.	\$159.95

Fits '09-'13 FLHR, FLHRC, FLHT, FLHX, FLTR and FLTRX, FLHRSE5, FLHXSE/2/3, FLTRSE3 and FLTRXSE/2 models. For use with H-D Detachables Sissy Bars, Solo Luggage Racks, Two-Up Luggage Racks, Solo Tour-Pak Rack and Two-Up Tour-Pak Rack. FLHRC models require separate purchase of Saddlebag Hinge Stop P/N 90580-09.

54205-09A	Chrome.	\$159.95
54246-09A	Gloss Black.	\$159.95

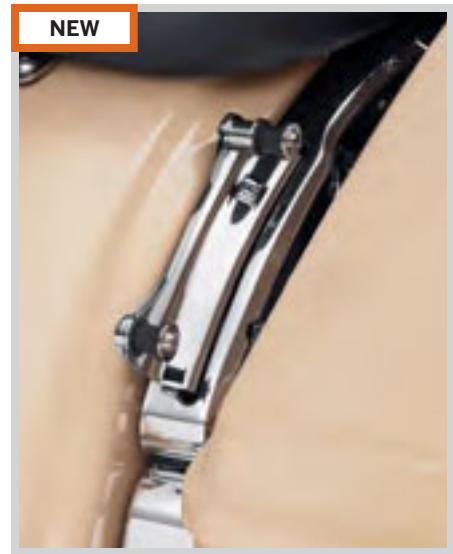

**A. 4-POINT DOCKING HARDWARE KIT – CHROME
'14-LATER MODELS**



**A. 4-POINT DOCKING HARDWARE KIT – GLOSS BLACK
'14-LATER MODELS**



A. 4-POINT DOCKING HARDWARE KIT – CHROME



**A. 4-POINT DOCKING HARDWARE KIT
'09-'13 MODELS**

A. 4-POINT DOCKING HARDWARE KIT – GLOSS BLACK

Notice: The prices appearing in this catalog are the manufacturer's suggested retail prices. Actual retail prices may vary.

TOURING & TRIKE 375

Backrests & Racks

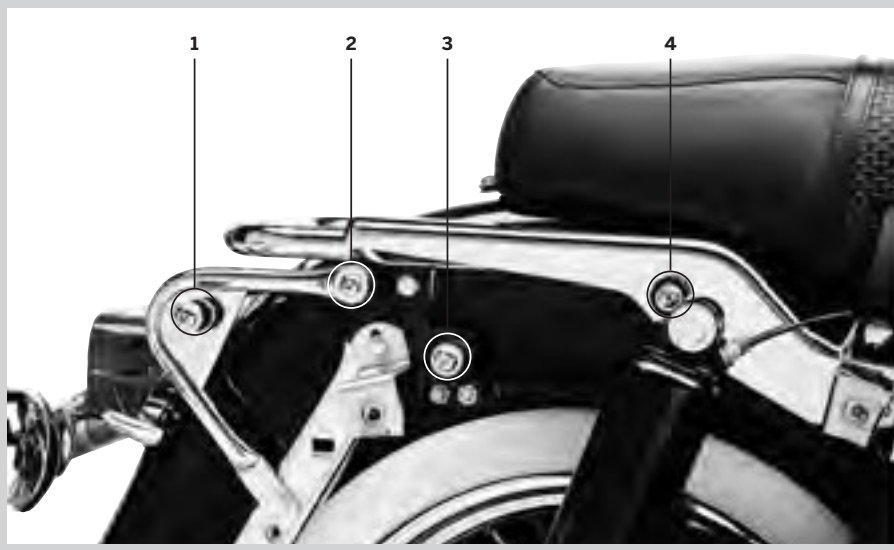

B. H-D DETACHABLES DOCKING HARDWARE KIT – '97-'08 TOURING MODELS

B. H-D® DETACHABLES™ DOCKING HARDWARE KITS – '97-'08 TOURING MODELS

For Sissy Bar, Solo Luggage Rack or Solo Tour-Pak®

Kit contains the docking hardware necessary to install H-D® Detachables™ accessories on your Road King®, Road Glide®, Street Glide® or Electra Glide® Standard model. Provides docking points to allow installation of detachable Passenger Backrest, Solo Luggage Rack or Solo Tour-Pak® Rack.

53803-06 **\$44.95**

Fits '97-'08 Touring models (except FLHTCUI and '07-'08 FLHRSE3/4).

For Two-Up Tour-Pak or Two-Up Luggage Rack

Kit contains the docking hardware necessary to install H-D Detachables accessories on your Road King, Road Glide, Street Glide or Electra Glide Standard model. Provides docking points to allow installation of detachable Two-Up Luggage Rack or Two-Up Tour-Pak.

53804-06 **\$59.95**

Fits '97-'08 Touring models (except FLHTCUI and '07-'08 FLHRSE3/4).

53988-07 **\$59.95**

Fits '07-'08 FLHRSE3/4 models.

Docking Hardware Fitment Matrix – '97-'08 Models

Touring Detachable	Docking Kit	Diagram
Sissy Bar Upright P/N 52933-97B, 52805-97B, 52935-04 or 52723-06	53803-06	3 & 4
Two-Up Luggage Rack P/N 53743-97	53804-06	1 & 2
Two-Up Tour-Pak Rack P/N 53276-04	53804-06	1 & 2
Solo Tour-Pak Rack P/N 53260-02	53803-06	3 & 4
Solo Luggage Rack P/N 53048-06	53803-06	3 & 4

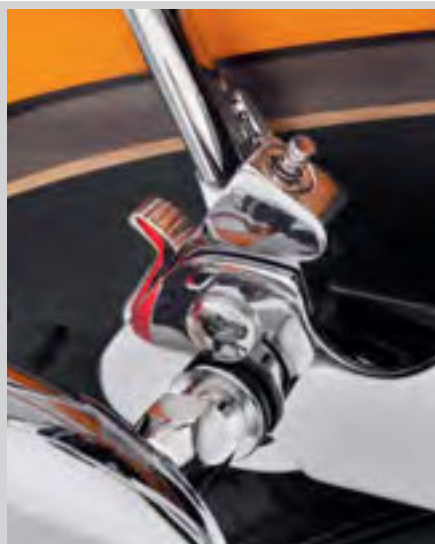

C. LOCKING H-D DETACHABLES LATCH KIT – CHROME

C. LOCKING H-D DETACHABLES LATCH KIT

This unique lock replaces the camlock on your Harley-Davidson® Detachables accessories, providing additional security and peace of mind when parking your vehicle. The kit includes two extended-reach barrel-style keys for easy access to the lock. Key registration and replacement service is available.

Fits all models equipped with detachable Sideplates, Racks and Tour-Pak Luggage Carriers (except '09-later Touring models equipped with detachable Solo Tour-Pak Rack).

90300087 Chrome. **\$79.95**

90300086 Black. **\$69.95**

D. H-D DETACHABLES LATCH KIT – CHROME

Decorative chrome latches are the perfect way to enhance the appearance of your detachable accessories. Meticulously polished and chrome-plated, these easy-to-install rotary latches are a direct replacement for the Original Equipment satin black parts and are a simple way to add a finishing touch to your ride. Latches feature an easy-to-pull finger release to simplify access in hard-to-reach areas.

12600036 **\$49.95**

Fits all models equipped with detachable Sideplates, One-Piece Sissy Bar Uprights, Racks and Tour-Pak Luggage Mounting Racks.



C. LOCKING H-D DETACHABLES LATCH KIT – BLACK

D. H-D DETACHABLES LATCH KIT – CHROME

Notice: The prices appearing in this catalog are the manufacturer's suggested retail prices. Actual retail prices may vary.

376 TOURING & TRIKE

Backrests & Racks

A. H-D® DETACHABLES™ Sissy Bar UPRIGHT

A sissy bar and passenger backrest pad is the starting point for building a complete touring machine. The backrest provides long-range comfort and support and adds a feeling of confidence and control for the passenger. Available in your choice of height, these H-D® Detachables™ One-Piece Uprights can be installed or removed in seconds to add versatility to your ride. A wide variety of Backrest Pads are available for separate purchase.

Fits '09-later Touring models equipped with required Docking Hardware Kits. '09-later Touring models equipped with rigid-mount Tour-Pak® require purchase of appropriate H-D Detachables Tour-Pak Conversion Kit.

52610-09	Short – Chrome.	\$179.95
54248-09	Short – Gloss Black.	\$179.95
52627-09	Standard-Height – Chrome.	\$179.95
54247-09	Standard-Height – Gloss Black.	\$179.95

Fits '97-'08 Road King®, FLHT, FLHX and FLTR models equipped with required Docking Kits. Fits '06-'08 FLHTC models equipped with H-D Detachables Tour-Pak Rack Mounting Kit P/N 53303-07 and Docking Hardware Kit P/N 53803-06.

52935-04	Short – Chrome.	\$179.95
52933-97B	Standard-Height – Chrome.	\$179.95
52723-06	Tall – Chrome.	\$179.95



A. H-D DETACHABLES Sissy Bar UPRIGHT – '09-LATER TOURING MODELS



A. SHORT H-D DETACHABLES Sissy Bar UPRIGHT – GLOSS BLACK



A. STANDARD-HEIGHT H-D DETACHABLES Sissy Bar UPRIGHT – CHROME



A. H-D DETACHABLES Sissy Bar UPRIGHT – '09-LATER MODELS

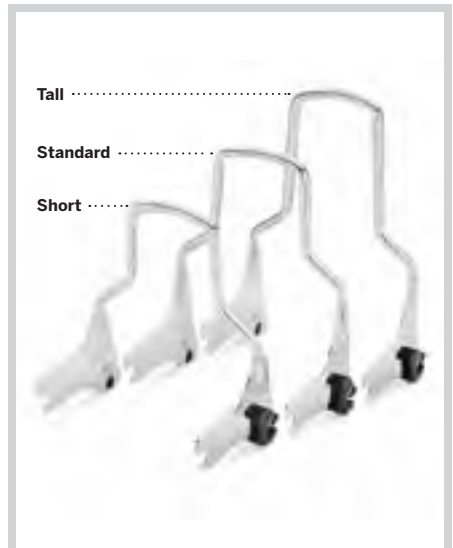

A. H-D DETACHABLES Sissy Bar UPRIGHT – '97-'08 MODELS

Notice: The prices appearing in this catalog are the manufacturer's suggested retail prices. Actual retail prices may vary.

TOURING & TRIKE 377

Backrests & Racks



B. PREMIUM H-D DETACHABLES BACKREST WITH ADJUSTABLE RECLINE



B. PREMIUM H-D® DETACHABLES™ BACKREST WITH ADJUSTABLE RECLINE

Enhance your passenger's ride with an adjustable passenger backrest. This adjustable backrest allows the passenger to change the recline angle for maximum comfort. Simply turn the glove-friendly locking knobs and adjust the upright to one of three different recline settings. The 3 position settings provide 16 degrees of adjustment, with the mid-position that matches a standard backrest recline. The exclusive cam lock H-D® Detachables™ design lets you add or remove the passenger backrest assembly in seconds. Available in chrome and gloss black finishes.

Fits '09-later Touring models equipped with required Docking Hardware Kits (except models equipped with Stealth Detach Luggage Rack). '09-later Touring models equipped with rigid-mount Tour-Pak® require purchase of appropriate H-D Detachables Tour-Pak Conversion Kit.

52300257	Standard-Height – Chrome.	\$299.95
52300258	Standard-Height – Gloss Black.	\$299.95

C. AIR WING SISSY BAR UPRIGHT

Combine long-range comfort with an impressive dose of style. The Air Wing Sissy Bar Upright features a sleek tapered profile capped with a beautifully crafted billet airfoil casting. The detachable sissy bar is designed to be installed or removed in seconds, adding versatility to your ride. Finish the look with the matching Air Wing Sissy Bar Backrest Pad P/N 52300302 and complementing Air Wing Two-Up Luggage Rack. The bar can be equipped with optional LED Light Kit P/N 68000076 (Red) or 68000077 (Smoked) for added rear visibility. Requires separate purchase of Wiring Harness P/N 70641-08.

Fits '09-later Touring models equipped with required Docking Hardware Kits (except models equipped with Stealth Detach Luggage Rack). '09-later Touring models equipped with rigid-mount Tour-Pak® require purchase of appropriate H-D Detachables Tour-Pak Conversion Kit.

52300146	Chrome.	\$259.95
52300147	Gloss Black.	\$259.95

Also available:

LED LIGHT KIT

This fast-acting LED Light Kit operates as a supplemental rear running light and brake light. The high, center-mount position places the light in the line-of-sight of following vehicles and the bright, fast-acting LED lamps get you noticed. Wiring is concealed inside the tubes for a clean, custom installation. Available with red or smoked lens.

Fits Air Foil Luggage Rack P/N 54290-11, 54291-11 and Air Wing Sissy Bar Upright P/N 52300146 and 52300147. Installation requires separate purchase of model-specific Wiring Harness Kit.

68000076	Red Lens.	\$44.95
68000077	Smoked Lens.	\$44.95

Also available:

LED LIGHT KIT WIRING HARNESS

Required for installation of LED Light Kit on Air Wing Sissy Bar Upright P/N 52300146 or 52300147.

70641-08		\$13.95
Fits '09-'13 Touring models equipped with Air Wing Sissy Bar Upright P/N 52300146 or 52300147.		

LED LIGHT KIT WIRING HARNESS

Required for installation of optional LED Light Kit on Luggage Racks and Passenger Backrests.

69200772		\$14.95
Fits '14-later Touring models equipped with Adjustable Luggage Rack P/N 50300044 or 50300076, Air Wing Racks P/N 54283-09, 50300008, 79179-08 or 53000062 and Air Wing Passenger Backrests P/N 52300146 or 52300147.		



B. PREMIUM H-D DETACHABLES BACKREST WITH ADJUSTABLE RECLINE – CHROME



B. PREMIUM H-D DETACHABLES BACKREST WITH ADJUSTABLE RECLINE – GLOSS BLACK

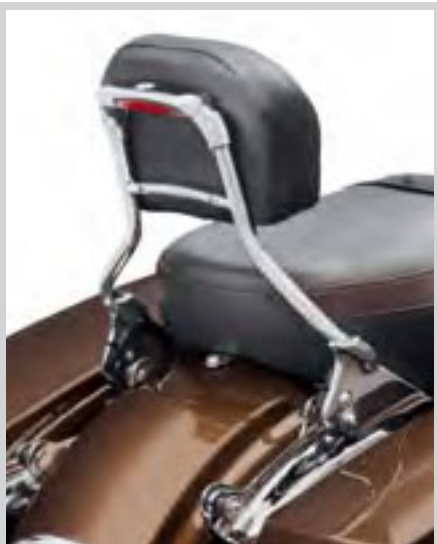

C. AIR WING SISSY BAR UPRIGHT – CHROME

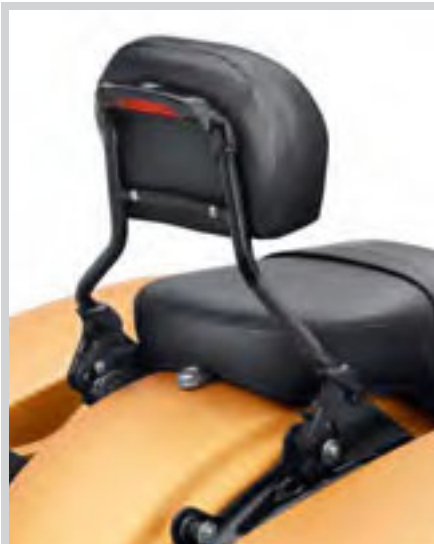

C. AIR WING SISSY BAR UPRIGHT – GLOSS BLACK

Notice: The prices appearing in this catalog are the manufacturer's suggested retail prices. Actual retail prices may vary.

378 TOURING & TRIKE

Backrests & Racks

A. COMPACT PASSENGER BACKREST PAD

Sized to complement low-profile custom seats, this Compact Leather Backrest Pad combines practical passenger support with custom compact style. The leather cover with smooth insert complements both synthetic and leather seating surfaces.

52408-07A **\$199.95**

Fits Short H-D® Detachables™ Passenger Sissy Bar Upright P/N 52935-04, 52610-09 or 54248-09. Will not fit seats with tall passenger pillion pads. Pad height 6.5"; width 10.5".



A. COMPACT PASSENGER BACKREST PAD

B. SHORT PASSENGER BACKREST PAD – SMOOTH LOOK

Smooth top-stitched pad complements most seating surfaces.

51579-05A **\$109.95**

Fits Short H-D Detachables Passenger Sissy Bar Upright P/N 52935-04, 52610-09 or 54248-09. Will not fit seats with tall passenger pillion pads. Pad height 6.5"; width 10.5".

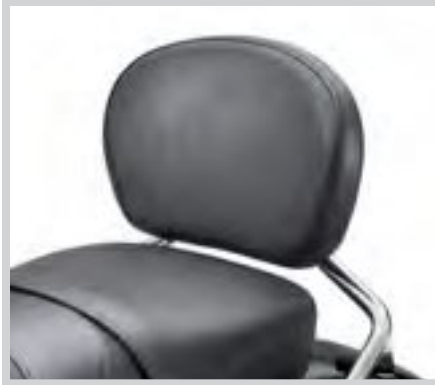

B. SHORT PASSENGER BACKREST PAD – SMOOTH LOOK

C. SHORT PASSENGER BACKREST PAD – MAHOGANY BROWN

Dressed in rich textured brown vinyl and finished with elegant gold stitching, this Short Passenger Backrest Pad is the perfect complement to the Mahogany Brown Seat and Pillion collection. Styled to match the '12 FLTRXSE model.

52300141A **\$119.95**

Fits Short H-D Detachables Passenger Sissy Bar Upright P/N 52935-04, 52610-09 or 54248-09. Will not fit seats with tall passenger pillion pads. Pad height 6.5"; width 10.5".



C. SHORT PASSENGER BACKREST PAD – MAHOGANY BROWN

D. SHORT PASSENGER BACKREST PAD – CVO ROAD GLIDE CUSTOM STYLING

Matches '13 CVO™ Road Glide® Original Equipment seat. (except the 110th Anniversary edition CVO FLTRXSE2).

52300300 **\$129.95**

Fits Short H-D Detachables Passenger Sissy Bar Upright P/N 52935-04, 52610-09 or 54248-09. Will not fit seats with tall passenger pillion pads. Pad height 6.5"; width 10.5".



D. SHORT PASSENGER BACKREST PAD – CVO ROAD GLIDE CUSTOM STYLING

E. SHORT PASSENGER BACKREST PAD – CVO STREET GLIDE CUSTOM STYLING

Matches '15 CVO™ Street Glide® Original Equipment seat.

52300361 **\$129.95**

Fits Short H-D Detachables Passenger Sissy Bar Upright P/N 52935-04, 52610-09 or 54248-09. Will not fit seats with tall passenger pillion pads. Pad height 6.5"; width 10.5".



NEW

E. SHORT PASSENGER BACKREST PAD – CVO STREET GLIDE CUSTOM STYLING

F. AIR WING PASSENGER BACKREST PAD

Styled to complement available touring and custom seats, this pad is shaped to fit the contour of the Air Wing Sissy Bar Upright P/N 52300146 or 52300147.

52300302 **\$99.95**

Fits '09-later Touring models equipped with the Air Wing Sissy Bar Upright P/N 52300146 or 52300147.

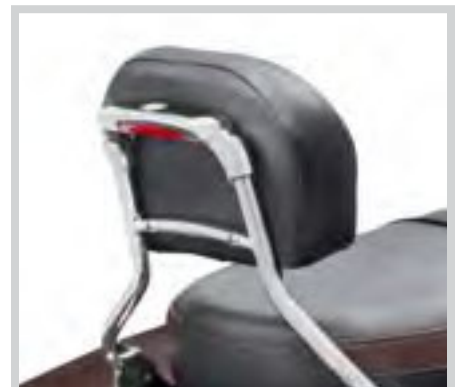

F. AIR WING PASSENGER BACKREST PAD

Notice: The prices appearing in this catalog are the manufacturer's suggested retail prices. Actual retail prices may vary.

TOURING & TRIKE 379

Backrests & Racks



G. MID-SIZED PASSENGER BACKREST PAD – LEATHER

PASSENGER BACKREST PADS – MID-SIZED

Sized to fit Standard-Height and Tall Touring Sissy Bar Uprights. Available to match a wide variety of seat stitch designs, these Mid-Sized Backrest Pads feature a gentle curved shape that cradles the spine and provides hours of passenger comfort.

Fits Standard-Height H-D® Detachables™ Passenger Sissy Bar Uprights P/N 52300324, 52627-09, 54247-09, 52933-97B or 52805-97B, Tall H-D Detachables Passenger Sissy Bar Upright P/N 52723-06, Premium H-D Detachables Sissy Bar Upright 52300257 or 52300258. Pad height 8.0"; width 12.0".

G. MID-SIZED PASSENGER BACKREST PAD – LEATHER

Styled to match Leather Low-Profile Bucket Seat P/N 52918-98A.

52920-98B **\$119.95**

H. MID-SIZED PASSENGER BACKREST PAD – TOP-STITCHED

Smooth top-stitched pad complements most seating surfaces.

52924-98B **\$109.95**

I. MID-SIZED PASSENGER BACKREST PAD – COMFORT STITCH

Styled to match Comfort Stitch Seats and Rider Backrests.

51727-05A **\$109.95**

J. MID-SIZED PASSENGER BACKREST PAD – CUSTOM STITCHING

Styled to match Road King® Custom models.

52657-04B **\$99.95**

K. MID-SIZED PASSENGER BACKREST PAD – '06-'10 STREET GLIDE® STITCHING

Styled to match the '06-'10 Street Glide® model.

51633-06A **\$109.95**



H. MID-SIZED PASSENGER BACKREST PAD – TOP-STITCHED

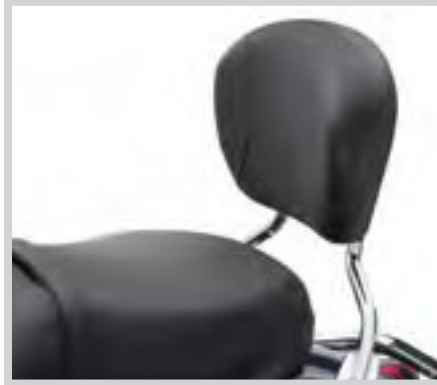

I. MID-SIZED PASSENGER BACKREST PAD – COMFORT STITCH



J. MID-SIZED PASSENGER BACKREST PAD – CUSTOM STITCHING



K. MID-SIZED PASSENGER BACKREST PAD – STREET GLIDE STITCHING

PASSENGER BACKREST PADS – OVERSIZED

Sized to fit Standard-Height and Tall Touring Sissy Bar Uprights. Available to match a wide variety of seat stitch designs, these Oversized Backrest Pads feature a large surface area and a generous curved shape that surrounds the passenger's lower back and provides added support for hours in the saddle.

Fits Standard-Height H-D Detachables Passenger Sissy Bar Uprights P/N 52300324, 52627-09, 54247-09, 52933-97B or 52805-97B, Tall H-D Detachables Passenger Sissy Bar Upright P/N 52723-06, Premium H-D Detachables Sissy Bar Upright 52300257 or 52300258. Pad height 9.5"; width 13.5".

L. OVERSIZED PASSENGER BACKREST PAD – SMOOTH

Smooth top-stitched pad complements most seating surfaces.

52886-98D **\$109.95**

M. OVERSIZED PASSENGER BACKREST PAD – STUDDED

Styled to match studded Original Equipment Road King and Road King Touring Seat P/N 51617-99C.

52709-97C **\$109.95**



L. OVERSIZED PASSENGER BACKREST PAD – SMOOTH



M. OVERSIZED PASSENGER BACKREST PAD – STUDDED

TOURING

Notice: The prices appearing in this catalog are the manufacturer's suggested retail prices. Actual retail prices may vary.

380 TOURING & TRIKE

Backrests & Racks

A. BILLET BACKREST PAD MOUNT

Chrome-plated billet aluminum and an engraved Bar & Shield emblem set the tone for this custom Passenger Backrest Mount, which will make you look even better as you're rolling by. Replaces the stock mounting plate and includes chrome-plated mounting hardware.

53086-04 Chrome. **\$69.95**

Fits Touring models equipped with H-D® Detachables™ Sissy Bar Upright P/N 52805-97B, 52933-97B, 52935-04, 52723-06, 52610-09, 52627-09, 25300257 or 52300258.

B. STYLED BACKREST PAD MOUNT

This custom Backrest Mounting Plate replaces the stamped metal mount for a distinctive look. The mirror-finished bracket, chrome-plated mounting hardware and Vivid Black insert contrasts with a leather or vinyl backrest pad to dress your Touring bike in style.

52825-05 Chrome. **\$49.95**

Fits Touring models equipped with H-D Detachables Sissy Bar Upright P/N 52805-97B, 52935-04, 52933-97B, 52723-06, 52610-09, 52627-09, 25300257 or 52300258.



A. BILLET BACKREST PAD MOUNT



B. STYLED BACKREST PAD MOUNT

C. QUICK-RELEASE Sissy BAR UPRIGHT – FREEWHEELER™ MODELS

Add passenger comfort and support to your Freewheeler™ Trike model. Designed to blend with the curved lines of the trunk lid, this standard-height polished chrome upright plugs into the Original Equipment docking ports and can be removed in seconds with a simple push of the release buttons. The one-piece upright accepts most mid-sized or oversized touring model passenger backrest pads (sold separately) and is the perfect finishing element for your long-distance touring machine.

52300324 Chrome. **\$249.95**

Fits '15-later FLRT models.

D. AIR WING LUGGAGE RACK – FREEWHEELER MODELS

The low-profile aerodynamic styling of the Air Wing Luggage Rack draws your eye with its sleek lines and the engraved Harley-Davidson script adds a signature touch. This full-sized rack protects the trunk lid from scratches. The die-cast wing and lightweight steel tubing are hand-polished before finishing for long-lasting beauty. Kit includes all necessary mounting hardware.

50300097 Chrome. **\$199.95**

Fits '15-later FLRT models.

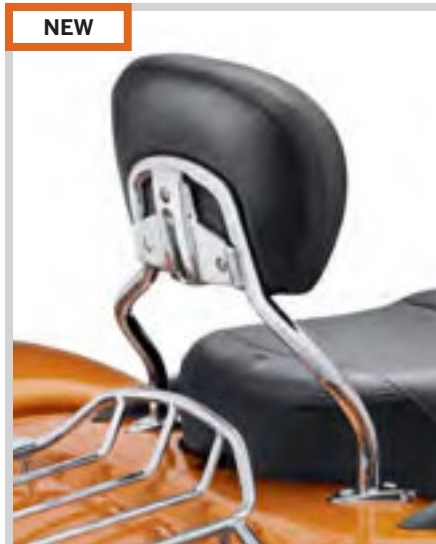

C. QUICK-RELEASE Sissy BAR UPRIGHT – FREEWHEELER MODELS (SHOWN WITH STYLED BACKREST MOUNT)



D. AIR WING LUGGAGE RACK – FREEWHEELER MODELS

Notice: The prices appearing in this catalog are the manufacturer's suggested retail prices. Actual retail prices may vary.

TOURING & TRIKE 381

Backrests & Racks



E. ADJUSTABLE TWO-UP LUGGAGE RACK – CHROME (CLOSED)



E. ADJUSTABLE TWO-UP LUGGAGE RACK – CHROME (OPEN)



E. ADJUSTABLE TWO-UP LUGGAGE RACK – FINGERTIP CONTROL



E. ADJUSTABLE TWO-UP LUGGAGE RACK – GLOSS BLACK (CLOSED)



F. KING H-D DETACHABLES TWO-UP LUGGAGE RACK – CHROME



F. KING H-D DETACHABLES TWO-UP LUGGAGE RACK – GLOSS BLACK

E. ADJUSTABLE TWO-UP LUGGAGE RACK*

Expand your options at the push of a button. This stylish rack offers style, function and practicality in one. The Adjustable Two-Up Luggage Rack features telescoping side extensions that allow the rider to customize the rack's width in seconds. To accommodate a wide soft bag or duffel, just press the buttons, slide out the side extensions and increase the usable surface area by 50%. When an oversize rack is not required, just slide in the extensions for a clean look. The beefy rack accommodates a load capacity up to 30 pounds and the side rails feature convenient mounting points that easily accept bag tie-down straps and bungee cords. The H-D® Detachables™ rack can be completely removed from the bike in seconds and is designed to accept the internally-wired LED Light Kit P/N 68065-10 or 68219-10 (sold separately) for added visibility from the rear. Rack Dimensions: 12.0" D x 12.75" W (Unexpanded); 12.0" D x 18.75" W (Expanded).

Fits '09-later Touring models equipped with 4-Point Docking Hardware Kits (except '09-later CVO™ models with rigid-mount Tour-Pak®). Models equipped with Original Equipment rigid-mount Tour-Pak require purchase of appropriate H-D Detachables Tour-Pak Rack Kit. FLHX, FLHXS, FLTR and FLTRX models require separate purchase of Antenna Relocation Kit or Hidden Antenna Kit. Some FLHRC EU registration plates may interfere with rack.

50300044	Chrome.	\$399.95
50300076	Gloss Black.	\$399.95

Also available:

LED LIGHT KIT

Fast-acting LED Light Kit operates as a supplemental rear running light and brake light. The high, center-mount position places the light in the line-of-sight of following vehicles and the bright, fast-acting red LED lamps get you noticed. Wiring is concealed inside the rack for a clean, custom installation. Available with red or smoked lens.

Fits '14-later Touring models equipped with Air Wing H-D Detachables Luggage Rack P/N 54283-09 and 50300008 and Adjustable Two-Up Luggage Rack P/N 50300044 or 50300076. Does not fit CVO models.

68000111	Red Lens.	\$69.95
68000116	Smoked Lens.	\$69.95

Fits '09-'13 Touring models equipped with Air Wing H-D Detachables Luggage Rack P/N 54283-09 and 50300008, Adjustable Two-Up Luggage Rack P/N 50300044 and 50300076. Does not fit CVO models.

68065-10	Smoked Lens.	\$59.95
68219-10	Red Lens.	\$54.95

F. KING H-D® DETACHABLES™ TWO-UP LUGGAGE RACK*

This stylish oversized King Two-Up Luggage Rack adds extra capacity for your cross-town or cross-country ride. The classic harp-shaped rack is constructed of large diameter steel rod, welded and perfectly polished for an elegant look. This rack is first in class with an increased load capacity up to 30 pounds. The large rack with side extensions offers a versatile flat load surface and the slotted side plates provide options for securing soft or rigid carrying bags. Designed to work with or without a H-D Detachables Passenger Backrest, the rack can be installed or removed from the bike in seconds.

Fits '09-later Touring models equipped with 4-point Docking Hardware Kits. '09-later Touring models equipped with rigid-mount Tour-Pak require purchase of appropriate H-D Detachables Tour-Pak Conversion Kit. FLHX, FLHXS, FLTR and FLTRX models require separate purchase of Antenna Relocation Kit or Hidden Antenna Kit. Some FLHRC EU registration plates may interfere with rack.

50300054	Chrome.	\$234.95
50300058	Gloss Black.	\$234.95



***WARNING:** Do not use this rack as a seat. Do not exceed the fender rack weight capacity. Using as seat or exceeding this capacity could cause handling problems which could result in loss of control and death or serious injury.

Notice: The prices appearing in this catalog are the manufacturer's suggested retail prices. Actual retail prices may vary.

382 TOURING & TRIKE

Backrests & Racks

A. AIR WING H-D® DETACHABLES™ TWO-UP LUGGAGE RACK*

The low-profile aerodynamic styling defines the look of this Luggage Rack. Designed to work with or without H-D® Detachables™ Passenger Backrests, this rack can be installed or removed from the Docking Hardware in seconds, creating a truly versatile ride. Available in mirror chrome or rich gloss black finish, the rack draws your eye with its sleek lines and the engraved Harley-Davidson script adds a signature touch. The die-cast wing and lightweight steel tubing are hand-polished before finishing for long-lasting beauty. Kit includes all necessary mounting hardware. For added visibility, the rack is designed to incorporate the internal wiring of the Air Wing Rack Light Kit (sold separately) for a clean look.

Fits '09-later Touring models equipped with 4-point Docking Hardware Kits. '09-later Touring models equipped with rigid-mount Tour-Pak® require purchase of appropriate H-D Detachables Tour-Pak Conversion Kit. FLHX, FLHXS, FLTR and FLTRX models require separate purchase of Antenna Relocation Kit or Hidden Antenna Kit. Some FLHRC EU registration plates may interfere with rack.

54283-09	Chrome.	\$249.95
50300008	Gloss Black.	\$249.95



A. AIR WING H-D DETACHABLES TWO-UP LUGGAGE RACK – GLOSS BLACK



A. AIR WING H-D DETACHABLES TWO-UP LUGGAGE RACK – CHROME

B. LED LIGHT KIT

Fits '14-later Touring models equipped with Air Wing H-D Detachables Luggage Rack P/N 54283-09 and 50300008 or Adjustable Two-Up Luggage Rack P/N 50300044 and 50300076. Requires separate purchase of model-specific wiring harness. Does not fit CVO™ models.

68000111	Red Lens.	\$69.95
68000116	Smoked Lens.	\$69.95

Fits '09-'13 Touring models equipped with Air Wing H-D Detachables Luggage Rack P/N 54283-09 and 50300008 or Adjustable Two-Up Luggage Rack P/N 50300044 and 50300076. Does not fit CVO models.

68065-10	Smoked Lens.	\$59.95
68219-10	Red Lens.	\$54.95



B. AIR WING LUGGAGE RACK LED LIGHT KIT



B. AIR WING LUGGAGE RACK LED LIGHT KIT

C. STEALTH H-D DETACHABLES TWO-UP LUGGAGE RACK*

Style and practicality in one. This classic four-bar H-D Detachables Luggage Rack flows with the long and lean lines of today's custom rides. The rails and curving support blend together for an integrated floating look and the "stealth" hidden hardware adds to the clean design.

Fits '09-later Touring models equipped with 4-point Docking Hardware Kits (except '09-later Touring models equipped with Premium H-D Detachables Backrest with Adjustable Recline P/N 523000257 and 523000258). '09-later Touring models equipped with rigid-mount Tour-Pak require purchase of appropriate H-D Detachables Tour-Pak Conversion Kit. FLHX, FLHXS, FLTR and FLTRX models require separate purchase of Antenna Relocation Kit or Hidden Antenna Kit. Some FLHRC EU registration plates may interfere with rack.

53472-09	Chrome.	\$299.95
53566-09	Gloss Black.	\$299.95



C. STEALTH H-D DETACHABLES LUGGAGE RACK – CHROME



C. STEALTH H-D DETACHABLES LUGGAGE RACK – GLOSS BLACK



***WARNING:** Do not use this rack as a seat. Do not exceed the fender rack weight capacity. Using as seat or exceeding this capacity could cause handling problems which could result in loss of control and death or serious injury.

Notice: The prices appearing in this catalog are the manufacturer's suggested retail prices. Actual retail prices may vary.

TOURING & TRIKE 383

Backrests & Racks

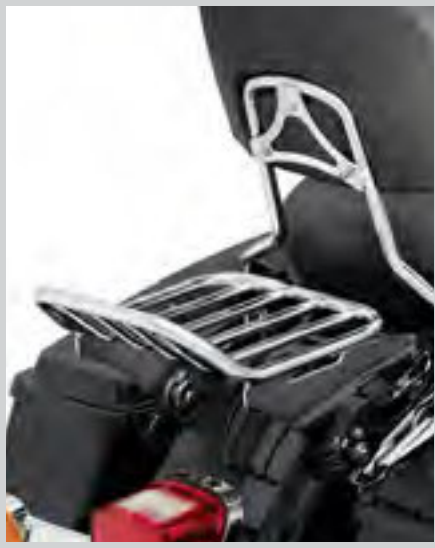

D. H-D DETACHABLES TWO-UP LUGGAGE RACK – CHROME



D. H-D DETACHABLES TWO-UP LUGGAGE RACK – GLOSS BLACK

D. H-D® DETACHABLES™ TWO-UP LUGGAGE RACK*

Smooth sweeping curves and a brilliant chrome finish defines the look of this Luggage Rack. Available in chrome or gloss black finish, this sleek and functional rack is an elegant solution for carrying your luggage across the country. Designed to work with or without H-D® Detachables™ Passenger Backrests, this rack can be installed or removed from the Docking Hardware in seconds, creating a truly versatile ride.

Fits '09-later Touring models equipped with 4-point Docking Hardware Kits. '09-later Touring models equipped with rigid-mount Tour-Pak® require purchase of appropriate H-D Detachables Tour-Pak Conversion Kit. FLHX, FLXS, FLTR and FLTRX models require separate purchase of Antenna Relocation Kit or Hidden Antenna Kit. Some FLHRC EU registration plates may interfere with rack.

54215-09	Chrome.	\$219.95
50300042	Gloss Black.	\$219.95

E. LUGGAGE RACK FOR H-D DETACHABLES PASSENGER SISSY BAR UPRIGHT*

This attractive chrome-plated rack adds additional versatility to your H-D Detachables Passenger Backrest. Designed to mount directly to the backrest upright, the rack and backrest can be easily removed or reinstalled as a unit to suit your touring or cruising style.

53011-98 **\$209.95**

Fits '94-'08 Touring models equipped with H-D Detachables Backrests P/N 52805-97B, 52933-97B and 52723-06. (Does not fit P/N 52935-04.) FLHRC and '07-'08 FLHRSE models also require separate purchase of Saddlebag Hinge Stop Kit P/N 90580-09.



E. LUGGAGE RACK FOR H-D DETACHABLES PASSENGER SISSY BAR UPRIGHT



F. H-D DETACHABLES TWO-UP LUGGAGE RACK

F. H-D DETACHABLES TWO-UP LUGGAGE RACK*

Designed to work with H-D Detachables Backrests, these racks allow you to convert from a two-up traveler to a solo rider in classic style.

53743-97 **\$209.95**

Fits '97-'08 Road King®, FLHT, FLHX and FLTR models equipped with required Docking hardware. FLTR and FLHX models require separate purchase of Antenna Relocation Kit P/N 76208-07. Does not fit with Layback License Plate Mounting Kit P/N 53385-00. Some EU registration plates may interfere with rack.

G. H-D DETACHABLES SOLO LUGGAGE RACK*

Add touring capabilities to your solo seat-equipped model in less than 60 seconds. This H-D Detachables Solo Rack fits over the fender when the passenger pillion is removed. The rack features sweeping curved rails and the chrome finish adds a stylish flair. Easily interchangeable with H-D Detachables Passenger Sissy Bar Upright.

54213-09A **\$249.95**

Fits '09-later FLHR, FLHRC, FLHT, FLHX, FLXS, FLTR, FLTRX, FLHRSE5, FLHXSE/2/3, FLTRSE3 and FLTRXSE/2 models equipped with a solo seat. Requires separate purchase of 2-Point or 4-Point Docking Hardware Kit.



G. H-D DETACHABLES SOLO LUGGAGE RACK – ('09-LATER MODELS SHOWN)



H. STEALTH RIGID LUGGAGE RACK

H. STEALTH RIGID LUGGAGE RACK*

Style and practicality in one. The classic four-bar luggage rack has been updated to flow with the long and lean lines of today's custom rides. The chrome-plated rails are rigid-mounted to the curving fender support and blend together for an integrated floating look and the "stealth" hidden hardware adds to the clean design.

53938-04 **\$309.95**

Fits '06-'08 FLHX models. Also fits '99-'08 Electra Glide® Standard, Road King (except FLHRSE3/4) and Road Glide® models with separate purchase of Bullet Turn Signal Bar and License Plate Relocation Kit P/N 53702-04.



***WARNING:** Do not use this rack as a seat. Do not exceed the fender rack weight capacity. Using as seat or exceeding this capacity could cause handling problems which could result in loss of control and death or serious injury.

Notice: The prices appearing in this catalog are the manufacturer's suggested retail prices. Actual retail prices may vary.

384 TOURING & TRIKE

Backrests & Racks

H-D® DETACHABLES™ TOUR-PAK® MOUNTING RACKS

Fully loaded, stripped down or anywhere in between, you can tailor your Harley-Davidson® Touring motorcycle to meet the demands of the highway. With H-D® Detachables™ docking hardware, you can transform your ride in the blink of an eye. Switch from a comfortable passenger backrest to load-hauling Tour-Pak® luggage in seconds. You can easily remove the Tour-Pak for easy maneuverability around town and reinstall it for an epic ride across the country. It's your choice and Harley-Davidson provides the flexibility to do it your way.



A. H-D DETACHABLES TWO-UP TOUR-PAK MOUNTING RACK



B. H-D DETACHABLES SOLO TOUR-PAK MOUNTING RACK



RACK INSTALLED



RACK REMOVED



***WARNING:** Do not use this rack as a seat. Do not exceed the fender rack weight capacity. Using as seat or exceeding this capacity could cause handling problems which could result in loss of control and death or serious injury.

Notice: The prices appearing in this catalog are the manufacturer's suggested retail prices. Actual retail prices may vary.

TOURING & TRIKE 385

Backrests & Racks

NEW



A. H-D DETACHABLES TWO-UP TOUR-PAK MOUNTING RACK – GLOSS BLACK

NEW



A. H-D® DETACHABLES™ TWO-UP TOUR-PAK® MOUNTING RACK*

Change your riding style in less than 60 seconds. The ultimate in touring flexibility, this Tour-Pak® Rack makes the convenience and protection of a Razor-Pak, Chopped, King or Leather Tour-Pak Luggage System a simple on-and-off proposition. Simple turn latches mount the rack to the bike's docking points and allow you to replace the Tour-Pak with a detachable sissy bar upright for around-town cruising. The mounting rack positions a Tour-Pak behind the passenger pillion and allows the passenger to use the luggage as a supporting backrest. Adjustable over a .75" range, the Tour-Pak can be located for maximum passenger room and comfort. Tour-Pak, Passenger Backrest Pad and Docking Hardware Kit sold separately.

Fits '14-later Road King®, Road Glide® and Street Glide® models. Requires separate purchase of Docking Hardware Kit. Street Glide and Road Glide models require Boom!™ Audio Hidden AM/FM/WB Antenna P/N 76000513 or Antenna Relocation Kit P/N 76000582.

53000221	Chrome.	\$199.95
53000459	Gloss Black.	\$199.95

Fits '09-'13 FLHR, FLHRC, FLHT, FLHX, FLTR, FLTRX, FLHRSE5, FLHXSE/2/3, FLTRSE3 and FLTRXSE/2 models. Requires separate purchase of 4-Point Docking Hardware Kit. FLHX and FLTR models require separate purchase of Tour-Pak Antenna Relocation Kit P/N 76556-09. FLHRSE5, FLHXSE/2/3, FLTRSE3 and FLTRXSE/2 models require separate purchase of Boom!™ Audio Hidden Antenna Kit P/N 76000266.

53276-09A	Chrome.	\$194.95
------------------	---------	-----------------

Fits '97-'08 Road King, FLHT, FLHX and FLTR models equipped with required docking hardware. FLTR and FLHX models require Antenna Relocation Kit P/N 76326-00A. Does not fit with Layback License Plate Mounting Kit P/N 53385-00. Some EU registration plates may interfere with Tour-Pak Rack. Models with rear fender tip trim can be adapted with the separate purchase of License Plate Relocation Kit P/N 60095-00A.

53276-04	Chrome.	\$194.95
-----------------	---------	-----------------

B. H-D DETACHABLES SOLO TOUR-PAK® MOUNTING RACK*

The Solo Tour-Pak Rack moves a Razor-Pak, Chopped or King Tour-Pak forward to a comfortable back-supporting position. The rack is designed to position the Tour-Pak for solo riding and is adjustable over a .75" range. Simply remove the Tour-Pak from the convenient H-D® Detachables™ docking hardware, add a passenger pillion and the bike is ready for two-up riding. Tour-Pak, Backrest Pad and Docking Hardware sold separately.

53000225	Chrome.	\$209.95
-----------------	---------	-----------------

Fits '14-later Road King, Road Glide and Street Glide models equipped with a solo seat. Requires separate purchase of Docking Hardware Kit and Boom!™ Audio Hidden AM/FM/WB Antenna P/N 76000513. Chopped Tour-Pak requires separate purchase of Tour-Pak Spacer Kit P/N 53000461. Not for use with Three-Pocket Fairing Pouch P/N 93300054 if used with Docking Kit P/N 52300131.

53260-09A	Chrome.	\$199.95
------------------	---------	-----------------

Fits '09-'13 FLHR, FLHRC, FLHT, FLHX, FLTR, FLTRX, FLHRSE5, FLHXSE/2/3, FLTRSE3 and FLTRXSE/2 models equipped with a solo seat. Requires separate purchase of 2-Point or 4-Point Docking Hardware Kit. FLHX and FLTR models require separate purchase of Tour-Pak Antenna Relocation Kit P/N 76556-09. FLHRSE5, FLHXSE/2/3, FLTRSE3 and FLTRXSE/2 models require separate purchase of Boom! Audio Hidden Antenna Kit P/N 76000266.

53260-02	Chrome.	\$209.95
-----------------	---------	-----------------

Fits '97-'08 Road King, FLHT, FLHX and FLTR models equipped with solo seat and required docking hardware.



A. H-D DETACHABLES TWO-UP TOUR-PAK MOUNTING RACK – '14-LATER MODELS



A. H-D DETACHABLES TWO-UP TOUR-PAK MOUNTING RACK – '09-'13 MODELS



A. H-D DETACHABLES TWO-UP TOUR-PAK MOUNTING RACK – '97-'08 MODELS



B. H-D DETACHABLES SOLO TOUR-PAK MOUNTING RACK – '14-LATER MODELS



B. H-D DETACHABLES SOLO TOUR-PAK MOUNTING RACK – '09-'13 MODELS



B. H-D DETACHABLES SOLO TOUR-PAK MOUNTING RACK – '97-'08 MODELS



***WARNING:** Do not use this rack as a seat. Do not exceed the fender rack weight capacity. Using as seat or exceeding this capacity could cause handling problems which could result in loss of control and death or serious injury.

Notice: The prices appearing in this catalog are the manufacturer's suggested retail prices. Actual retail prices may vary.

TOURING

386 TOURING & TRIKE

Backrests & Racks

A. H-D® DETACHABLES™ TOUR-PAK® CONVERSION KIT ^{1,2} – '14-LATER

Transform your Electra Glide® model for around-town cruising. This kit includes everything needed to convert the rigid-mount Tour-Pak® luggage to an easy on-and-off detachable version. Complete kit includes Docking Hardware Kit, H-D® Detachables™ Two-Up Tour-Pak Mounting Rack, AM/FM Antenna Relocation Kit, License Plate Relocation Kit and Red Lens Electra Glo™ LED Saddlebag Run/Turn/Tail Lamp Kit.

53000291 **\$569.95**

Fits '14-later FLHTCU, FLHTCUL, FLHTK, FLHTKL, FLHTKSE and FLTRUSE models. Models equipped with CB require separate purchase of CB Antenna Relocation Kit P/N 76000308. CVO™ models separate purchase of Lighting Module P/N 69200949.

Also available:

CB ANTENNA RELOCATION KIT

Relocates your CB antenna to the rear fender to accommodate use with a H-D Detachables Two-Up Tour-Pak Luggage Mounting Rack. Kit includes mounting bracket, all mounting hardware and wiring harness.

76000308 **\$69.95**

Fits '14-later FLHTCU, FLHTCUL, FLHTK, FLHTKL, FLHTKSE and FLTRUSE models equipped with Detachable Tour-Pak Conversion Kit P/N 53000291.

B. H-D DETACHABLES TOUR-PAK CONVERSION KIT¹ – '97-'13

Transform your Electra Glide model for around-town cruising. This kit includes everything needed to convert the rigid-mount Tour-Pak to an easy on-and-off detachable version. Complete kit includes two-up docking hardware kit, H-D Detachables Two-Up Tour-Pak Rack, chrome license plate holder, reflector and AM/FM antenna relocation hardware.

53246-09B **\$549.95**

Fits '09-'13 FLHTC, FLHTCU, FLHTK and FLTRU models. FLHTCU and FLHTK require separate purchase of Wiring Harness P/N 70032-09. FLTRU models require separate purchase of Wiring Harness P/N 69200181.

53303-07 **\$329.95**

Fits '97-'08 FLHTC models. '97-'05 models require separate purchase of Light Harness Kit P/N 70113-08.

Also available:

TOUR-PAK QUICK DISCONNECT HARNESS FOR ULTRA MODELS

Wiring Harness Kit allows the installation of Detachable Tour-Pak Rack Kit on specified models.

70032-09 **\$89.95**

Fits '09-'13 FLHTCU and FLHTK models equipped with Detachable Tour-Pak Rack Kit P/N 53246-09A.

69200181 **\$99.95**

Fits '11-'13 FLTRU models equipped with Detachable Tour-Pak Rack Kit P/N 53246-09A.

70113-08 **\$14.95**

Fits '97-'05 FLHTC models equipped with Detachable Tour-Pak Kit P/N 53303-07.

NEW



H-D DETACHABLES TOUR-PAK CONVERSION KIT – '14-LATER MODELS

NEW



A. H-D DETACHABLES TOUR-PAK CONVERSION KIT – '14-LATER MODELS

NEW



B. H-D DETACHABLES TOUR-PAK CONVERSION KIT – '97-'08 MODELS



¹ WARNING: Do not use this rack as a seat. Do not exceed the fender rack weight capacity. Using as seat or exceeding this capacity could cause handling problems which could result in loss of control and death or serious injury.



² WARNING: Disconnecting your DOT requirement brake lamp could reduce your visibility to others and result in death or serious injury.



B. H-D DETACHABLES TOUR-PAK CONVERSION KIT – '09-'13 MODELS

Notice: The prices appearing in this catalog are the manufacturer's suggested retail prices. Actual retail prices may vary.



NEW



NEW

C. TOUR-PAK LUGGAGE AND SADDLEBAG INTERIOR LIGHT KIT – '14-LATER MODELS

TOURING & TRIKE 387

Tour-Pak® Luggage

C. TOUR-PAK® LUGGAGE AND SADDLEBAG INTERIOR LIGHT KIT

Don't be left in the dark. This bright convenience lamp kit turns nighttime into day when you open your Tour-Pak® luggage or saddlebag. A brilliant white LED light pod mounts inside the Tour-Pak luggage to illuminate the interior and the two available LED light pods mount to the bottom of the Tour-Pak luggage to cast light inside the open saddlebags. Each LED light pod features a soft-touch micro switch for ease of activation and a 5-minute auto shutoff timer to prevent battery drain.

3-Light Tour-Pak & Saddlebag Light Kit

68000151 **\$119.95**
Fits '14-later Touring models equipped with rigid or detachable King Tour-Pak Luggage.

54331-04A **\$119.95**
Fits '93-'13 Touring models equipped with rigid or detachable King or Chopped Tour-Pak Luggage.

1-Light Tour-Pak Light Kit

68000152 **\$94.95**
Fits '14-later Touring models equipped with rigid or detachable King Tour-Pak Luggage.

54332-04A **\$94.95**
Fits '93-'13 Touring models equipped with rigid or detachable King or Chopped Tour-Pak Luggage.

69200289 **\$89.95**
Fits '09-'13 Trike models equipped with a King Tour-Pak.

2-Light Saddlebag Light Expansion Kit

68000153 **\$59.95**
Fits '14-later Touring models equipped with King Tour-Pak and Tour-Pak Interior Light Kit P/N 68000151.

1-Light Saddlebag Light Expansion Kit

54333-04A **\$38.95**
Fits '93-'13 Touring models equipped with King or Chopped Tour-Pak Luggage and Tour-Pak Interior Light Kit P/N 54331-04A.



C. TOUR-PAK LUGGAGE INTERIOR LIGHT KIT – '93-'13 MODELS

D. TRUNK INTERIOR LIGHT KIT

Don't be left in the dark. This bright convenience lamp kit turns nighttime into day when you open your Trike's trunk. Two brilliant white LED light pods mount inside the trunk to illuminate the interior and the included contact switch turns the light on and off when you open and close the door. A 5-minute auto shut-off timer prevents battery drain. Kit includes wiring harness and installation hardware.

83946-11 Fits '09-later FLHTCUTG models. **\$84.95**



C. TOUR-PAK INTERIOR LIGHT KIT – TRIKE



D. TRUNK INTERIOR LIGHT KIT

Notice: The prices appearing in this catalog are the manufacturer's suggested retail prices. Actual retail prices may vary.

COLOR-MATCHED TOUR-PAK® LUGGAGE

When you're serious about racking up miles, Tour-Pak® luggage systems will help you pack for the trip. This Color-Matched hard luggage provides the capacity to pack for almost any riding condition. Carry the rain gear, clothing and camping equipment you need for a ride across the country or pack the groceries on a run to the corner store. Tour-Pak luggage is available in primed finish or Color-Matched to many factory color combinations. Solid colors, solid colors with complementing pinstripes and two-tone finishes are available to match most late-model Harley-Davidson color schemes.

Tour-Pak luggage systems are available in three capacities. The Razor-Pak is sized to carry a briefcase, laptop computer or a change of clothes, the Chopped Tour-Pak offers a low-profile shape, styled to complement a long and lean Touring bike and the King Tour-Pak is sized to provide maximum storage space.

Tour-Pak luggage can be installed on Touring models equipped with rigid or H-D® Detachables™ Tour-Pak Racks. Passenger backrest pads are available to complement Original Equipment or accessory seats.

KING TOUR-PAK LUGGAGE – '97-'13 MODELS



CAPACITY 4,260 CI

Add long-haul convenience and storage capacity to your Road King®, Street Glide® or Electra Glide® Standard model. Color-Matched to the motorcycle base color, this Tour-Pak is factory drilled for wrap-around backrest (sold separately). Tour-Pak includes hinges and latches, bottom reinforcement plate, luggage box mat, map pouch and chrome side accents. King Tour-Pak can be equipped with optional wrap-around LED rear and side light kits (sold separately).

KING TOUR-PAK LUGGAGE – '14-LATER MODELS



CAPACITY 4,290 CI

Turn your Touring model into a complete cross-country touring machine. The color-matched King Tour-Pak carrier features a streamlined profile that complements the sleek design of the '14-later Rushmore models. Tour-Pak is factory drilled for wrap-around backrest (sold separately) and equipped with chrome hinges, chrome one-touch latch, chrome side accents, luggage box mat and lid tether. Optional LED rear and side light kits are available.

CHOPPED TOUR-PAK LUGGAGE – '97-'13 MODELS



CAPACITY 3,285 CI

Achieve a radical touring profile with this 3.0" lower Tour-Pak. The traditional Tour-Pak luggage shape has been chopped and sectioned for a sleek, sporty look, while maintaining the practical weather tight and secure storage that the long-distance rider demands. The Chopped Tour-Pak is completely assembled with factory hinges and latches and is pre-drilled for your choice of Chopped Tour-Pak backrest pads (sold separately).

CHOPPED TOUR-PAK LUGGAGE – '14-LATER MODELS



CAPACITY 3,285 CI

Get ready to travel in style. The slim profile of the Chopped Tour-Pak is the perfect match for your radical custom bagger. But don't let the silhouette fool you – the Chopped Tour-Pak has loads of room to store all your gear. The Chopped Tour-Pak is factory drilled for your choice of Chopped Tour-Pak backrest pads (sold separately), and equipped with chrome hinges, chrome one-touch latch, luggage box mat and lid tether.

KING TOUR-PAK® LUGGAGE

See pages 806-807 for a complete list of available Color-Matched options.



**2014-LATER COLOR-MATCHED KING TOUR-PAK LUGGAGE
(SHOWN WITH H-D DETACHABLES TWO-UP TOUR-PAK RACK AND BACKREST PAD)**



**1997-2013 COLOR-MATCHED KING TOUR-PAK LUGGAGE
(SHOWN WITH H-D DETACHABLES TWO-UP TOUR-PAK RACK, BACKREST PAD AND SIDE LIGHT COVER)**

Available to fit:

Fits '14-later Road King®, Road Glide®, Street Glide® and select CVO™ models. Separate purchase of H-D® Detachables™ Two-Up or Solo Tour-Pak Mounting Rack and applicable Docking Hardware is required. Separate purchase of Tour-Pak Lock Kit P/N 90300030 is required.

Fits '09-'13 Electra Glide® Standard, Road King, Road Glide, Street Glide, Street Glide Trike and select CVO models. Separate purchase of detachable Two-Up or Solo Tour-Pak Mounting Rack and applicable Docking Hardware is required. Separate purchase of Tour-Pak Lock Kit P/N 53194-07 is required. FLHXXX models require addition of Tour-Pak Installation Kit P/N 54144-10 and Spacer Kit P/N 83294-10.

Fits '06-'08 Electra Glide Standard, Road King, Road Glide and Street Glide models. Separate purchase of detachable Two-Up or Solo Tour-Pak Mounting Rack and applicable Docking Hardware is required. Separate purchase of Tour-Pak Lock Kit P/N 53194-07 is required.

Fits '07-'05 Electra Glide Standard, Road King, and Road Glide models. Separate purchase of detachable Two-Up or Solo Tour-Pak Mounting Rack and applicable Docking Hardware is required. Separate purchase of Tour-Pak Lock Kit P/N 53194-07 is required.

390 TOURING & TRIKE

Tour-Pak® Luggage

CHOPPED TOUR-PAK® LUGGAGE

See pages 806-807 for a complete list of available Color-Matched options.



**2014-LATER COLOR-MATCHED CHOPPED TOUR-PAK LUGGAGE
(SHOWN WITH H-D DETACHABLES TWO-UP TOUR-PAK RACK AND BACKREST PAD)**



**1997-2013 COLOR-MATCHED CHOPPED TOUR-PAK LUGGAGE
(SHOWN WITH H-D DETACHABLES TWO-UP TOUR-PAK RACK AND BACKREST PAD)**

Available to fit:

Fits '14-later Road King®, Road Glide®, Street Glide® and select CVO™ models. Does not fit FLRT models. Separate purchase of H-D® Detachables™ Two-Up or Solo Tour-Pak Mounting Rack and applicable Docking Hardware is required. Separate purchase of Tour-Pak Lock Kit P/N 90300030 is required.

Fits '97-'13 Touring models. FLHTCUTG models require separate purchase of Spacer Kit P/N 83294-10. FLHXXX models require addition of Tour-Pak Installation Kit P/N 54144-10 and Spacer Kit P/N 83294-10.

RAZOR-PAK LUGGAGE

The ultimate in touring style. The slim but surprisingly roomy Razor-Pak Luggage is designed to add convenient luggage-carrying capacity without distracting from the lean look of your custom bagger. Ideal size to carry a briefcase, laptop computer or a change of clothes, the locking Razor-Pak top case can actually swallow compact half-helmets and some lightweight riding gear. So, get in a good day at the office, change your gear and hit Main Street in style. Razor-Pak Luggage can be mounted to rigid or H-D® Detachables™ Tour-Pak® mounting racks and accepts many of the lid racks, trim, spoilers and other accessories available for Chopped and King Tour-Pak Luggage.



**1997-2013 COLOR-MATCHED RAZOR-PAK LUGGAGE
(SHOWN WITH H-D DETACHABLES TWO-UP TOUR-PAK RACK AND BACKREST PAD)**



CAPACITY 1,900 CI

Surprisingly roomy Razor-Pak luggage is designed to add convenient luggage-carrying capacity without distracting from the lean look of your custom bagger.



**1997-2013 COLOR-MATCHED RAZOR-PAK LUGGAGE
(SHOWN WITH H-D DETACHABLES TWO-UP TOUR-PAK RACK AND BACKREST PAD)**

Fits '97-'13 Touring models. FLHTCUTG models require addition of Spacer Kit P/N 83294-10. FLHXXX models require addition of Tour-Pak Rack Kit P/N 54144-10 and Spacer Kit P/N 83294-10.

79175-10BDK	Unpainted.	\$699.95
79175-12DJO	Big Blue Pearl.	\$799.95
79175-10BYM	Black Denim.	\$799.95
79175-10BPY	Black Pearl.	\$799.95
79175-13DPU	Candy Orange.	\$799.95
79175-12DGV	Chrome Yellow.	\$799.95
79175-12DJS	Ember Red Sunglo.	\$799.95
79175-12DKJ	Midnight Pearl.	\$799.95
79175-10CYS	Red Hot Sunglo.	\$799.95
79175-10DGX	Sedona Orange.	\$799.95
79175-10DH	Vivid Black.	\$799.95
79175-10CGS	White Gold Pearl.	\$799.95

Shown with:

RAZOR-PAK BACKREST PAD – SMOOTH

Clean, smooth styling complements most seating surfaces.

79192-10 **\$139.95**

Fits '97-'13 models equipped with Razor-Pak luggage.

392 TOURING & TRIKE

Tour-Pak® Luggage

A. TOUR-PAK® LUGGAGE

Add cross-country luggage capacity to your ride with accessory Tour-Pak® Luggage. A cavernous interior will hold one full-face helmet or two half helmets. Kit includes backrest pad, interior rubber mat, hardware and instructions. Luggage capacity: 2,500 cubic inches. Dimensions: 18.5" W x 17.0" D x 13.0" H. Racks and docking kits sold separately. International models may require separate purchase of License Plate Relocation Kit P/N 60095-00A.

Fits '04-later XL models (except XL883N, XL1200C, XL1200N and XL1200T) equipped with Solo Tour-Pak Rack. Fits '00-later Softail® models (except FLS, FLSTNSE, FLSTSE/2/3 and FXCW, FXCWC, FXS, FXSB, FXSBSE, FXSTD, FXSTSSE3) equipped with H-D® Detachables™ Solo or Two-Up Tour-Pak Rack. Fits '97-'13 Touring models equipped with H-D Detachables Two-Up or Solo Tour-Pak Racks.

53147-98C **\$699.95**
Road King Classic Leather Styling.

53690-06A **\$514.95**
Smooth Vinyl.

53057-07A **\$729.95**
CVO Road King Flamed Leather Styling. Installation requires separate purchase of Lock Set P/N 54360-05.



A. ROAD KING CLASSIC LEATHER TOUR-PAK LUGGAGE

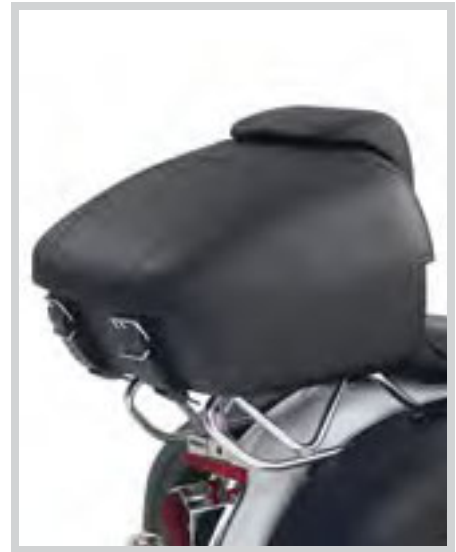

A. SMOOTH VINYL TOUR-PAK LUGGAGE

B. LEATHER TOUR-PAK LOCK SET

Designed to discourage grab-and-run theft, this Lock Set provides a level of security that leather straps alone can't match. The complete kit includes external locking push-button latch release, locking mechanism, release cable, two keys, steel Tour-Pak lid mounting plate and all required installation hardware. Special order keyed-to-match lock sets are available for models with barrel-type keys. Contact your Dealer with your vehicle key code.

54360-05 **\$199.95**
Fits models equipped with Leather or Synthetic Leather Tour-Pak Luggage (except P/N 79189-06).



A. CVO ROAD KING FLAMED LEATHER TOUR-PAK LUGGAGE



B. LEATHER TOUR-PAK LOCK SET

C. PREMIUM LEATHER TOUR-PAK LUGGAGE

This king-sized Tour-Pak will provide all the storage capacity you need for a trip across the country. This smooth leather-wrapped luggage is highlighted with an embossed ostrich pattern insert, leather braiding and custom stitching and features a raised center section to accommodate most full-face helmets. Tour-Pak includes Chrome Luggage Rack, Chrome Accent Spears and Interior Light. Kit does not include Tour-Pak mounting rack, hardware or instructions to relocate an antenna on models equipped with a radio or CB.

79189-06 **\$1,499.95**
Fits '97-'08 Road King®, Road Glide®, Electra Glide® Standard and Street Glide® models equipped with Tour-Pak Rack and appropriate Docking Hardware Kits. Road Glide and Street Glide models require separate purchase of Antenna Relocation Kit P/N 76326-00A. All models require separate purchase of Tour-Pak Installation Kit P/N 90067-06, Keyed-to-Match Tour-Pak Lock P/N 53865-06A, Lock Clip P/N 53868-06 and Fitted Tour-Pak Liners P/N 91814-06 and 53230-06. International models may require separate purchase of License Plate Relocation Kit P/N 60095-00A.

Shown with:

TOUR-PAK INSTALLATION KIT

Kit includes wrap-around passenger backrest pad and required Tour-Pak installation hardware. Does not include Tour-Pak mounting rack.

90067-06 **\$399.95**
Required for installation of Premium Leather Tour-Pak Luggage P/N 79189-06 on '97-'08 Road King, Road Glide, Electra Glide Standard and Street Glide models.



C. PREMIUM LEATHER TOUR-PAK LUGGAGE (SHOWN WITH TOUR-PAK INSTALLATION KIT)

Notice: The prices appearing in this catalog are the manufacturer's suggested retail prices. Actual retail prices may vary.

TOURING & TRIKE 393

Tour-Pak® Luggage

CHOPPED TOUR-PAK® BACKREST PADS

Chopped Tour-Pak® Backrest Pads provide deep padded support for your passenger and a low-profile shape that complements the low, lean look of your Tour-Pak. Easy to install, the floating design of the integrated mounts reduce the contact between the pad and the Tour-Pak to minimize paint scuffing. Chopped Backrest Pads are available in a wide variety of styles to match most seating surfaces.

D. CHOPPED TOUR-PAK BACKREST PAD – SMOOTH

Clean, smooth styling complements most seating surfaces.

52300319 **\$169.95**

Fits '14-later Touring and Tri Glide® models equipped with Chopped Tour-Pak luggage.

52898-98A **\$169.95**

Fits '97-'13 Touring models equipped with Chopped Tour-Pak luggage.

E. CHOPPED TOUR-PAK BACKREST PAD – CVO™ STREET GLIDE STYLING

Matches '15 CVO™ Street Glide® Original Equipment seat.

52300359 **\$199.95**

Fits '14-later Touring and Tri Glide models equipped with Chopped Tour-Pak luggage.

F. CHOPPED TOUR-PAK BACKREST PAD – CVO ROAD KING STYLING

Matches '14 CVO™ Road King® Original Equipment seat with leather tuck and roll inlay.

52300335 **\$209.95**

Fits '14-later Touring and Tri Glide models equipped with Chopped Tour-Pak luggage.

G. CHOPPED TOUR-PAK BACKREST PAD – CVO ROAD GLIDE® CUSTOM STYLING

Matches '13 CVO Road Glide® Custom Original Equipment seat. (except the 110th Anniversary edition CVO FLTRXSE2).

52300298 **\$209.95**

Fits '97-'13 Touring models equipped with Chopped Tour-Pak luggage.

H. CHOPPED TOUR-PAK BACKREST PAD – '06-'10 STREET GLIDE STYLING

Styled to match the '06-'10 Street Glide® Original Equipment or Sundowner™ seat.

51635-06 **\$199.95**

Fits '97-'13 Touring models equipped with Chopped Tour-Pak luggage.



D. CHOPPED TOUR-PAK BACKREST PAD – SMOOTH
'14-LATER MODELS



D. CHOPPED TOUR-PAK BACKREST PAD – SMOOTH
'97-'13 MODELS



E. CHOPPED TOUR-PAK BACKREST PAD – '15 CVO STREET GLIDE STYLING



F. CHOPPED TOUR-PAK BACKREST PAD – '14 CVO ROAD KING STYLING



G. CHOPPED TOUR-PAK BACKREST PAD – '13 CVO ROAD GLIDE CUSTOM STYLING



H. CHOPPED TOUR-PAK BACKREST PAD – '06-'10 STREET GLIDE STYLING

Notice: The prices appearing in this catalog are the manufacturer's suggested retail prices. Actual retail prices may vary.

394 TOURING & TRIKE

Tour-Pak® Accessories

A. SUN RAY® HEATED KING TOUR-PAK® BACKREST PAD

Take the chill out of cool spring days and brisk fall nights with a heated wrap-around backrest pad. The Sun Ray® Pad features a convenient high/low/off toggle control that directs two levels of soothing warmth right where you need it. This one-piece pad with integrated heat element and thermostatic control system is simple to install and the heating element is switched off with the ignition to avoid draining the battery. Available in Smooth or Comfort Stitch styles, this pad can be teamed with a Sun Ray or Harley® Hammock Heated Seat for the ultimate in back and bottom comfort.

Fits '14-later Touring and Tri Glide® models equipped with King Tour-Pak® luggage.

52300317 Comfort Stitch. **\$349.95**

Fits '97-'13 Touring and Trike models equipped with King Tour-Pak. Models not equipped with separate Tour-Pak backrest lower pad require separate purchase of Tour-Pak Lower Backrest Pad P/N 52400020.

54387-11 Comfort Stitch. **\$349.95**

Shown with:

TOUR-PAK LOWER BACKREST PAD

One-piece pad provides lower back comfort and protects the Tour-Pak box from scuffs and scratches. Black vinyl surface complements most leather and vinyl seats and King Tour-Pak backrests. Kit includes pad and all necessary installation hardware.

52400020 **\$39.95**

Fits '97-'13 Touring and Trike models equipped with King Tour-Pak luggage.

KING TOUR-PAK BACKREST PADS

Wrap-Around King Tour-Pak Backrest Pads are shaped to surround your passenger in comfort. The curved shape cradles the back and the integrated side wings fit naturally beneath your passenger's arms for added support. These backrests feature easy-to-install isolation mounts to reduce contact between the pad and the Tour-Pak. King Backrest Pads are available in a variety of styles to match most seating surfaces.

B. KING TOUR-PAK BACKREST PAD – COMFORT STITCH

Styled to match the Comfort Stitch Touring Seat series.

52300314 **\$229.95**

Fits '14-later Touring and Tri Glide models equipped with King Tour-Pak luggage.

52395-03B **\$229.95**

Fits '97-'13 Touring and Trike models equipped with King Tour-Pak luggage.

C. KING TOUR-PAK BACKREST PAD – SMOOTH

Clean, smooth styling complements most seating surfaces.

52300312 **\$219.95**

Fits '14-later Touring and Tri Glide models equipped with King Tour-Pak luggage.

52892-98B **\$219.95**

Fits '97-'13 Touring and Trike models equipped with King Tour-Pak luggage.



A. SUN RAY HEATED KING TOUR-PAK BACKREST PAD – COMFORT STITCH '14-LATER MODELS



A. SUN RAY HEATED KING TOUR-PAK BACKREST PAD – COMFORT STITCH '97-'13 MODELS



B. KING TOUR-PAK BACKREST PAD – COMFORT STITCH '14-LATER MODELS

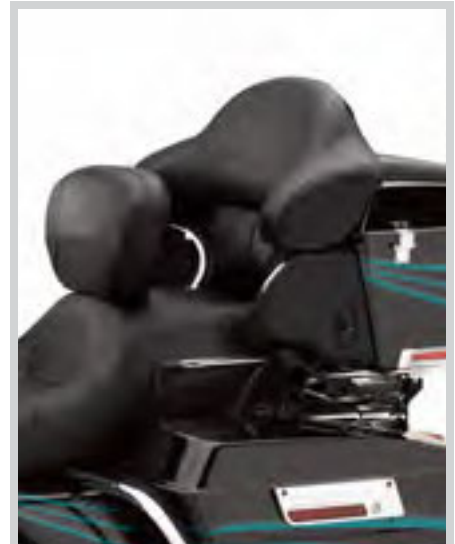

B. KING TOUR-PAK BACKREST PAD – COMFORT STITCH '97-'13 MODELS



C. KING TOUR-PAK BACKREST PAD – SMOOTH '14-LATER MODELS

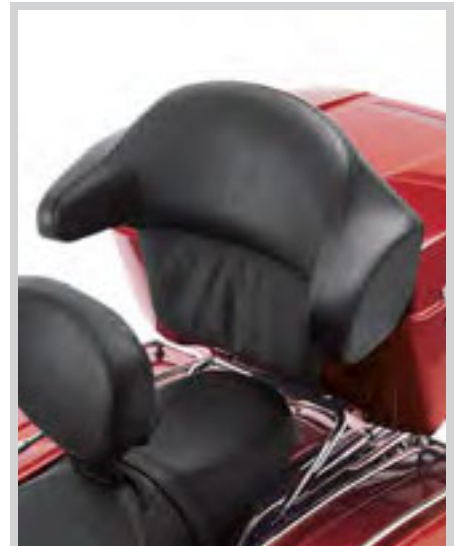

C. KING TOUR-PAK BACKREST PAD – SMOOTH '97-'13 MODELS

Notice: The prices appearing in this catalog are the manufacturer's suggested retail prices. Actual retail prices may vary.

TOURING & TRIKE 395

Tour-Pak® Accessories

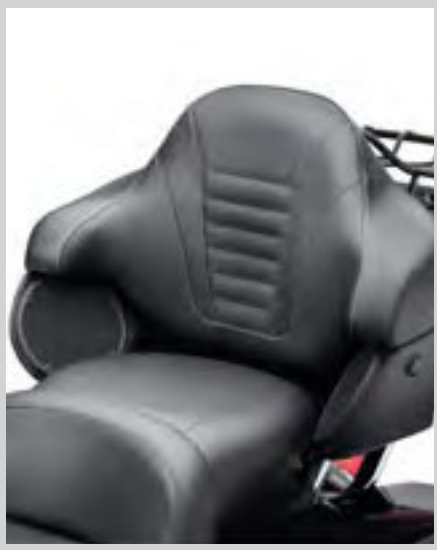

D. KING TOUR-PAK BACKREST PAD – '14 CVO ROAD KING STYLING



E. KING TOUR-PAK BACKREST PAD – '13 CVO ROAD GLIDE CUSTOM STYLING



F. KING TOUR-PAK BACKREST PAD – '15 CVO STREET GLIDE STYLING



G. KING TOUR-PAK BACKREST PAD – LEATHER ROAD ZEPPELIN

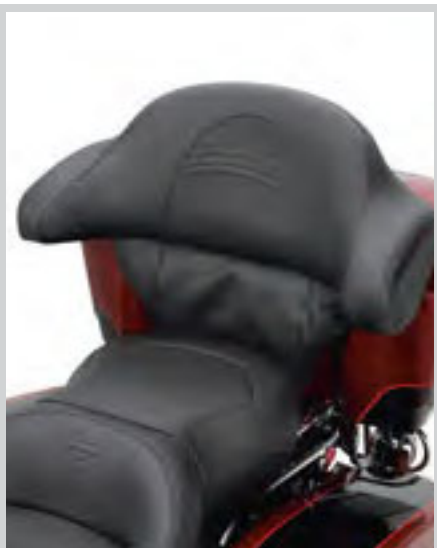

H. KING TOUR-PAK BACKREST PAD – '06-'10 STREET GLIDE STYLING



I. KING TOUR-PAK BACKREST PAD – ROAD KING STYLING

D. KING TOUR-PAK BACKREST PAD – CVO™ ROAD KING® STYLING

Matches '14 CVO™ Road King® Original Equipment seat.

52300334 \$299.95

Fits '14-later Touring and Tri Glide® models equipped with King Tour-Pak® luggage.

E. KING TOUR-PAK BACKREST PAD – CVO ROAD GLIDE CUSTOM STYLING

Matches '13 CVO Road Glide® Original Equipment seat (except the 110th Anniversary edition CVO FLTRXSE2).

52300295 \$299.95

Fits '97-'13 Touring and Trike models equipped with King Tour-Pak luggage.

F. KING TOUR-PAK BACKREST PAD – CVO STREET GLIDE STYLING

Matches '15 CVO Street Glide® Original Equipment seat.

52300360 \$299.95

Fits '14-later Touring and Tri Glide models equipped with King Tour-Pak luggage.

G. KING TOUR-PAK BACKREST PAD – LEATHER ROAD ZEPPELIN®

Styled to match the tufted leather Road Zeppelin® seat.

52335-97A \$299.95

Fits '97-'13 Touring and Trike models equipped with King Tour-Pak luggage.

H. KING TOUR-PAK BACKREST PAD – '06-'10 STREET GLIDE STYLING

Styled to match the '06-'10 Street Glide Original Equipment or Sundowner™ seat.

51634-06A \$239.95

Fits '97-'13 Touring and Trike models equipped with King Tour-Pak luggage.

I. KING TOUR-PAK BACKREST PAD – ROAD KING STYLING

Embroidered "Road King" logo and smooth look matches your stock FLHR seat.

52274-94B \$229.95

Fits '94-'13 Touring and Trike models equipped with King Tour-Pak luggage.

396 TOURING & TRIKE

Tour-Pak® Accessories

A. AIR WING TOUR-PAK® LUGGAGE RACK*

The low-profile aerodynamic styling of the Air Wing Tour-Pak® Luggage Rack enhances the look of any Razor-Pak, Chopped or King Tour-Pak lid. Available in mirror-chrome or rich gloss black finish, the rack draws your eye with its sleek lines and the engraved Harley-Davidson script adds a signature touch. This full-sized rack protects both Tour-Pak lid and passenger backrest from scratches. The die-cast wing and lightweight steel tubing are hand-polished before finishing for long-lasting beauty. Kit includes all necessary mounting hardware. For added visibility, the rack is designed to incorporate the internal wiring of the Air Wing Rack Light Kit P/N 68271-08 or 68250-08 (sold separately) for a clean look.

Fits King, Chopped and Razor-Pak Tour-Pak lids. Mounting hole pattern matches Premium Tour-Pak Luggage Rack P/N 53665-87.

79179-08	Chrome.	\$199.95
5300063	Gloss Black.	\$199.95



A. AIR WING TOUR-PAK LUGGAGE RACK – CHROME



A. AIR WING TOUR-PAK LUGGAGE RACK – GLOSS BLACK

B. AIR WING RACK LED LIGHT KIT

Custom fit to the Air Wing Tour-Pak Rack, this fast-acting LED Light Kit operates as a supplemental rear running light and brake light. The high, center-mount position places the rear light in the line-of-sight of following vehicles and the bright, fast-acting LED lamps get you noticed. Wiring is concealed inside the rack tubes for a clean, custom installation.

Fits '14-later Touring and Trike models equipped with Air Wing Tour-Pak Luggage Rack P/N 79179-08 or 5300063. Also fits '14-later FLHTKSE and '15-later FLTRUSE models with Original Equipment Tour-Pak Rack.

68000112	Red Lens.	\$69.95
68000113	Smoked Lens.	\$69.95

Fits '97-'13 Touring models equipped with the Air Wing Tour-Pak Luggage Rack P/N 79179-08 or 5300063. Also fits FLHTCUSE4/5/6/7/8 models with Original Equipment Tour-Pak Rack.

68271-08A	Smoked Lens.	\$69.95
68250-08A	Red Lens.	\$69.95



B. AIR WING RACK LED LIGHT KIT – SMOKED LENS



C. PREMIUM TOUR-PAK LUGGAGE RACK

C. PREMIUM TOUR-PAK LUGGAGE RACK*

This full-sized rack is especially designed to complement Tour-Pak lids with armrest-style passenger backrests. Protects both Tour-Pak lid and passenger backrest from scratches. Lightweight steel tubing incorporates high-quality welded joints and is hand-polished and chrome-plated using copper as a base coat followed by nickel and chrome to provide long-lasting beauty. Comes complete with all necessary mounting hardware.

53665-87		\$129.95
-----------------	--	-----------------

Fits King, Chopped and Razor-Pak Tour-Pak lids.



D. STEALTH TOUR-PAK LUGGAGE RACK*

Style and practicality in one. This classic six-bar Tour-Pak luggage rack flows with the long and lean lines of today's custom rides. The cantilevered aerodynamic rails appear to float above the center spar, imparting a lighter-than-air profile. Hidden hardware adds to the clean design. The Stealth Rack mounts in the same position as the Original Equipment Ultra Limited rack or the accessory Premium and Air Wing Tour-Pak luggage racks, so no additional drilling is required on those models. Use Bungee Cord Soft-Hook Extensions P/N 52300140 to keep your luggage firmly in place.

Fits King, Chopped and Razor-Pak Tour-Pak lids. Does not fit with Color-Matched Tour-Pak Spoiler kits.

53000242	Chrome.	\$239.95
53000247	Gloss Black.	\$239.95



D. STEALTH TOUR-PAK LUGGAGE RACK – CHROME



D. STEALTH TOUR-PAK LUGGAGE RACK – GLOSS BLACK



***WARNING:** Do not use this rack as a seat. Do not exceed the fender rack weight capacity. Using as seat or exceeding this capacity could cause handling problems which could result in loss of control and death or serious injury.

Notice: The prices appearing in this catalog are the manufacturer's suggested retail prices. Actual retail prices may vary.

TOURING & TRIKE 397

Tour-Pak® Accessories



**E. TOUR-PAK ACCENT RAIL – CHROME
'14-LATER MODELS**

E. TOUR-PAK® ACCENT RAIL – CHROME

Fabricated from highly polished steel tubing, these premium quality chrome-plated Accent Rails frame the wrap-around Tour-Pak® lights for a custom look. The rails provide an added level of protection from pass-by contact. Kit includes all necessary mounting hardware.

53000229 **\$129.95**

Fits '14-later FLHTCU, FLHTCUL, FLHTK, FLHTKL, FLHTCUTG and models equipped with accessory King Tour-Pak and LED Wrap-Around Light. Does not fit CVO™ FLHTKSE or FLTRUSE models.

53667-89A **\$109.95**

Fits '13-earlier Ultra Classic® models (except FLHTCUSE5/6/7/8) and any King Tour-Pak equipped with King Tour-Pak Brake/Tail Lamp Kit P/N 68012-88E.



**E. TOUR-PAK ACCENT RAIL – CHROME
'13-EARLIER MODELS**

F. TOUR-PAK REAR LIGHT TRIM

Add a custom touch to the Original Equipment Tour-Pak rear lighting. This mirror-chrome trim covers the satin black surface and adds a brilliant finishing touch to the rear of the bike. Self-adhesive mounting simplifies installation.

53000329 **\$79.95**

Fits '14-later FLHTCU, FLHTCUL, FLHTK, FLHTKL, FLHTCUTG and models equipped with accessory King Tour-Pak and LED wrap-around tail lamp.

G. ULTRA TOUR-PAK BRAKE LIGHT ACCENT COVERS – CHROME

Kit includes a pair of triple chrome-plated steel brake lamp accents and a complementing chrome center trim piece that wraps any Ultra King Tour-Pak luggage.

59239-93 **\$104.95**

Fits '89-'13 FLHTCU and FLHTCUTG models and other Touring models equipped with King Tour-Pak and Ultra Classic Brake Lamp Kit P/N 68012-88E. (Does not fit '10-'13 FLHTCUSE.)



F. TOUR-PAK REAR LIGHT TRIM



G. ULTRA TOUR-PAK BRAKE LIGHT ACCENT COVERS – CHROME

Notice: The prices appearing in this catalog are the manufacturer's suggested retail prices. Actual retail prices may vary.

398 TOURING & TRIKE

Tour-Pak® Accessories

A. LED KING TOUR-PAK® BRAKE/TURN/TAIL LAMP KIT – SMOKED

Add a sinister touch to the rear of your bike. This smoked LED lamp kit is a direct plug-in replacement for the stock LED red lens wrap-around Tour-Pak® light. The bright fast-acting LEDs glow bright red when activated, but nearly disappear behind the dark smoke lens when off. The lamp features a flat black surround that complements any solid or two-tone paint color and accommodates single and dual-antenna applications. No cutting or splicing is required for installation.

67800368 Smoked Lens. **\$299.95**
Fits '14-later FLHTCU, FLHTCUL, FLHTK, FLHTKL and FLHTCUTG models.



A. LED KING TOUR-PAK BRAKE/TURN/TAIL LAMP KIT – SMOKED

B. LED KING TOUR-PAK BRAKE/TURN/TAIL LAMP KIT

Add high-mount turn signals, running and brake lamps to your Classic and Ultra King Tour-Pak. This wrap-around light kit is equipped with bright, fast-acting LED lamps that grab the attention of following traffic. The corner lights operate in run/brake/turn mode and the center lamp functions as a run and brake lamp. The slim-line design mounts to the exterior surface of the Tour-Pak and can be used to replace the Original Equipment Ultra-style lamp. When equipped with Tour-Pak Liner P/N 53302-07 (sold separately), this kit eliminates the interior bulges and maximizes the carrying capacity inside. Available with smoked or red lens, the lamp features a flat black surround that complements any solid or two-tone paint color. Kit accommodates single and dual-antenna applications. No cutting or splicing is required for installation and kit includes a simple drilling template, interior mounting plates, mounting hardware and wiring harness.

Fits '97-'13 Touring models (except CVO™) equipped with King Tour-Pak luggage.

67931-11 Smoked Lens. **\$499.95**
67932-11 Red Lens. **\$499.95**



B. LED KING TOUR-PAK BRAKE/TURN/TAIL LAMP KIT – RED LENS

C. KING TOUR-PAK BRAKE/TAIL LAMP KIT

Dual filament bulbs provide both brake and tail lamp. Meets DOT requirements. Includes template to assist in cutting out lens housing openings, step-by-step instructions, wiring and all necessary mounting hardware. Dealer installation recommended.

68172-06 **\$239.95**
Fits '97-'13 FLHTCU, FLHTK, FLTRU, FLHTCUTG and other models equipped with Ultra-style Tour-Pak. (Does not fit '10-'13 FLHTCUSE.)

68012-88E **\$239.95**
Fits '88-'05 King Tour-Pak. (NOTE: Kit accommodates single antenna applications.)

NOTE: Original Equipment on Ultra Classic® Models.



B. LED KING TOUR-PAK BRAKE/TURN/TAIL LAMP KIT – SMOKED LENS



C. KING TOUR-PAK BRAKE/TAIL LAMP KIT

Notice: The prices appearing in this catalog are the manufacturer's suggested retail prices. Actual retail prices may vary.

NEW

TOURING & TRIKE 399

Tour-Pak® Accessories



D. TOUR-PAK SIDE MARKER LIGHT TRIM

D. TOUR-PAK® SIDE MARKER LIGHT TRIM

Add a custom touch to the Original Equipment Tour-Pak® side lighting. Mirror-chrome trim surrounds the side marker lights for a bit of flash and the self-adhesive backing simplifies installation. Kit includes left and right side trim.

53000330 **\$79.95**

Fits '14-later Electra Glide® and Tri Glide® models with Original Equipment King Tour-Pak-mounted side lights. Also fits '14-later models equipped with accessory King Tour-Pak and Side Marker Light Kits P/N 54352-09 or 69494-06.

E. TOUR-PAK SIDE MARKER LIGHT KIT

This wrap-around Side Marker Light Kit adds a splash of light to the lower edge of the Tour-Pak Luggage System. Kit replaces the chrome side trim along the lower edge of the Tour-Pak on Electra Glide Classic models or replaces the Original Equipment red lens featured on Ultra Classic® Electra Glide and Tri Glide models. Available in your choice of red or smoked lens. The smoked lens remains stealthy while the ignition is off, but glows red when the lights are switched on. Complete kit includes left and right lens housings, wiring harness and all required installation hardware.

54352-09 Smoked Lens. **\$119.95**

Fits '06-later Touring and Trike models equipped with King Tour-Pak luggage.

69494-06 Red Lens. **\$119.95**

Fits '06-later Touring and Trike models equipped with King Tour-Pak luggage. Original Equipment on the '06-later FLHTCU, FLHTCUL, FLHTK, FLHTKL and FLHTCUTG models.

F. TOUR-PAK SIDE LIGHT ACCENT COVERS – CHROME

Formed of triple chrome-plated steel, these easy-to-install accent covers add a touch of flash to your Tour-Pak side marker lights. Sold in pairs.

59349-97 Fits '97-'05 King Tour-Pak Luggage. **\$69.95**



E. TOUR-PAK SIDE MARKER LIGHT KIT – SMOKED (ON)



E. TOUR-PAK SIDE MARKER LIGHT KIT – RED

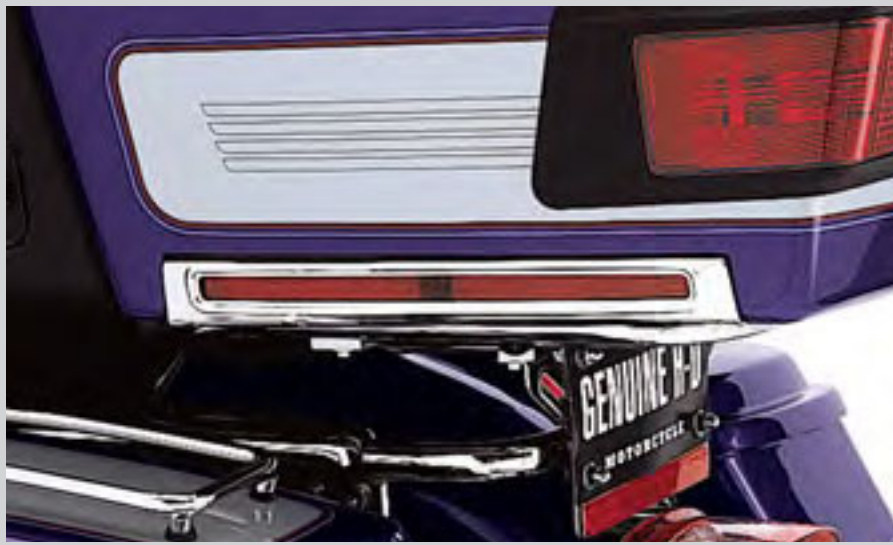

F. TOUR-PAK SIDE LIGHT ACCENT COVERS – CHROME

TOURING

Notice: The prices appearing in this catalog are the manufacturer's suggested retail prices. Actual retail prices may vary.

400 TOURING & TRIKE

Tour-Pak® Accessories

A. TOUR-PAK® HINGE AND LATCH KIT – GLOSS BLACK

Upgrade the appearance of your Tour-Pak® luggage. These Original Equipment-style hinges and latch are polished and finished in rich gloss black. The complete kit includes hinges, latch and all necessary hardware.

53000343 \$199.95

Fits '14-later Touring and Tri Glide® models equipped with Chopped or King Tour-Pak Luggage.



A. TOUR-PAK HINGE AND LATCH KIT – GLOSS BLACK

B. PREMIUM TOUR-PAK HINGES

Upgrade the appearance of your Tour-Pak with billet-style premium hinges. Styled to complement the Original Equipment Tour-Pak latches, these hinges add a clean, bold look with no exposed hardware. Available in mirror-chrome or gloss black finish, the complete kit includes two hinges and all necessary hardware. Drill is required to remove the factory installed hinge mounting rivets.

Fits '88-'13 Touring and Trike models equipped with Razor-Pak, Chopped or King Tour Pak luggage.

79211-08A Chrome. \$52.95

53000131 Gloss Black. \$52.95



B. PREMIUM TOUR-PAK HINGES – CHROME

B. PREMIUM TOUR-PAK HINGES – GLOSS BLACK

C. PREMIUM TOUR-PAK LATCHES

Styled to complement the Premium Tour-Pak Hinges, these die-cast latches provide a bold look to your ride. Designed to eliminate the traditional catch and clamp design, these latches make access to the Tour-Pak luggage easier than ever. Simply press down on the top of the lid to secure the latching mechanism. The self-aligning design positions the lid perfectly for no-fuss closure. A simple push of the button releases the lock and pops the lid open for convenience. Latches feature hidden hardware for a clean appearance and the front latch wraps around the Original Equipment lock for a custom touch. Kit includes front and rear latch and all mounting hardware.

Fits '06-'13 Touring and Trike models equipped with King or Ultra Tour-Pak Luggage. Does not fit with Leather, Razor-Pak or Chopped Tour-Pak Luggage. Does not fit models equipped with Tour-Pak Lock Covers P/N 53000217 or 53000218.

53000252 Chrome. \$109.95

53000253 Gloss Black. \$99.95



C. PREMIUM TOUR-PAK LATCHES – CHROME

C. PREMIUM TOUR-PAK LATCHES – GLOSS BLACK

D. TOUR-PAK LOCK COVER

This elegant die-cast cover with a Bar & Shield logo adds a custom touch to your Tour-Pak lock. Simply use your thumb to rotate the domed cover to expose the Original Equipment lock. A detent holds the cover in the open position and provides unhindered access for your key. Easy to install, the protective cover is held firmly in place by the Original Equipment lock and lock mounting hardware.

Fits '88-'13 Touring and Trike models equipped with King, Razor-Pak or Chopped Tour-Pak Luggage. Does not fit with Premium Tour-Pak Latches P/N 53000252 or 53000253.

53000217 Chrome. \$32.95

53000218 Gloss Black. \$32.95



D. TOUR-PAK LOCK COVER – CHROME

D. TOUR-PAK LOCK COVER – GLOSS BLACK

Notice: The prices appearing in this catalog are the manufacturer's suggested retail prices. Actual retail prices may vary.

TOURING & TRIKE 401

Tour-Pak® Accessories



E. TOUR-PAK LATCHES – GLOSS BLACK

E. TOUR-PAK® LATCHES – GLOSS BLACK

Add a custom touch to your Tour-Pak® luggage. Styled to complement available gloss black Premium Tour-Pak Hinges, these Original Equipment-style latches are polished and finished in rich gloss black. The complete kit includes latches, hasps and all necessary hardware.

53000130 **\$39.95**

Fits '88-'13 Touring and Trike models equipped with Razor-Pak, Chopped or King Tour-Pak Luggage.

F. EZ TOUR-PAK LID CATCH

Add the convenience of a self-aligning Tour-Pak lid to your Touring bike. Simply close the lid and latch it down. This easy-to-install kit eliminates the need to shift the position of the lid because the latches line up perfectly every time.

53000195 **\$14.95**

Fits '85-'13 Touring and Trike models equipped with King, Ultra or Razor-Pak Tour-Pak Luggage. Does not fit Chopped, Leather or Sport Tour-Pak Luggage.



F. EZ TOUR-PAK LID CATCH

G. TOUR-PAK SPEAR TRIM KIT – CHROME

These die-cast and chrome-plated trim spears add a sweeping slash of chrome to the Tour-Pak lid. These easy-to-install self-adhesive spears can also be used to cover the mounting holes when removing Tour-Pak Lid Rack P/N 53665-87 or 53101-96.

53887-05 **\$43.95**

Fits '93-'13 Touring and Trike models with King, Chopped or Razor-Pak Tour-Pak Luggage.

H. TOUR-PAK LID ACCENT PANEL – CHROME AND SIMULATED LEATHER

Chrome and leather are the classic materials to dress your Harley® motorcycle. And this Chrome and Simulated Leather Accent Panel is just the thing for customizing your Tour-Pak. The mirror-finish heavy chrome trim band with "Harley-Davidson" logo surrounds a field of black vinyl that fits the recess on your Tour-Pak lid. Includes installation hardware.

53911-01 **\$64.95**

Fits '93-'05 Touring models equipped with King or Chopped Tour-Pak. (Does not fit with Mini Tour-Pak Lid Rack P/N 53100-96.) Will not fit with previously installed Tour-Pak Lid Organizer P/N 53249-01A.



G. TOUR-PAK SPEAR TRIM KIT – CHROME



H. TOUR-PAK LID ACCENT PANEL – CHROME AND SIMULATED LEATHER

I. RETRACTABLE TOUR-PAK LID TETHER

Add the convenience of a Retractable Tether to your Tour-Pak. When extended to its full length, the strong cord holds the lid open at least 10° past vertical for improved stability and easy packing. Then the device automatically coils the tether cord inside the housing to eliminate pinched cords when closing the lid. The attractive housing with Bar & Shield logo attaches to the existing mounting points and replaces the Original Equipment cord.

54171-11 **\$31.95**

Fits '13-earlier Touring and Trike models equipped with a King, Ultra, Chopped or Razor-Pak Tour-Pak Luggage. Will not fit Leather or Sport Tour-Pak Luggage.

J. RETRACTABLE TRUNK DOOR TETHER

Add the convenience of a Retractable Tether to your Trike trunk door. The tethers easily mount to your trunk door and replace the stock support cords. When you open the trunk door, the tether smoothly deploys from the housing to support the door in the full open position. Then as you close the door, the device automatically coils the tether cord inside the housing to eliminate pinched cords. The attractive housing with Bar & Shield logo attaches to the existing mounting points. Sold in pairs.

53000237 Fits '11-later Tri Glide® models. **\$54.95**



I. RETRACTABLE TOUR-PAK LID TETHER



J. RETRACTABLE TRUNK DOOR TETHER

Notice: The prices appearing in this catalog are the manufacturer's suggested retail prices. Actual retail prices may vary.

402 TOURING & TRIKE

Saddlebag Accessories

A. COLOR-MATCHED SADDLEBAG LID SPOILER KIT*

Aero styling and a practical addition to rear visibility. Color-matched Saddlebag Lid Spoilers equipped with bright fast acting LED lamps that will get you noticed.

'14-later Models

Designed for easy installation, these Saddlebag Lid Spoilers feature your choice of Red- or Smoked-lens LED lamps (sold separately) that function as auxiliary running, brake and turn signals.

Fits '14-later Touring models with hard saddlebags and Saddlebag Lid Spoiler Light Kit P/N 90200735 or 90200736.

'93-'13 Models

Saddlebag Lid Spoilers include integrated bright red LED auxiliary running/brake lights that are a simple plug-in installation on '97-'13 models.

Fits '93-'13 Touring models with Color-Matched Hard Saddlebags.

Also available:

LED LIGHT KIT – SADDLEBAG SPOILERS

Custom fit to Saddlebag Lid Spoilers, these fast-acting LED Light Kits operate as a supplemental rear running light, brake light and turn signals. The bright, fast-acting red LED lamps get you noticed and the mounting position places the light above the traditional rear fender-mounted lamps and closer to the line-of-sight of following vehicles. Wiring is concealed for a clean, custom installation. Available with red or smoked lens.

Fits '14-later Touring models equipped with Saddlebag Spoiler Kit (sold in pairs).

90200735	Red Lens.	\$99.95
90200736	Smoked Lens.	\$99.95

B. COLOR-MATCHED TOUR-PAK® SPOILER KIT*

The combination of contoured styling and the practicality of an integrated auxiliary LED running/brake light blend form and function into the Tour-Pak® Spoiler.

'14-later Models

Designed for easy installation, the Tour-Pak Spoiler features a high-mounted LED running and brake light that gets you noticed. You choose Red- or Smoked-lens LED lamp (sold separately) to match your styling direction.

Fits '14-later Touring models equipped with King or Chopped Tour-Pak luggage and Tour-Pak Spoiler Light Kit P/N 53000238 or 53000239.

'97-'13 Models

Easy-to-install Tour-Pak Spoiler kit includes brilliant red-lens LED lamp and wiring harness.

Fits '97-'13 Touring and Trike models with King, Chopped or Razor-Pak Tour-Pak luggage. Spoiler may contact antennas on FLHTK models.

Also available:

LED LIGHT KIT – TOUR-PAK SPOILERS

Custom fit to Tour-Pak Spoilers, these fast-acting LED Light Kits operate as a supplemental rear running light and brake light. The high mounting position places the light in the line-of-sight of following vehicles, and the bright, fast-acting red LED lamps get you noticed. Wiring is concealed for a clean, custom installation. Available with red or smoked lens.

Fits '14-later Touring models equipped with Tour-Pak Spoiler Kit. FLHX, FLHXS, FLTRX and FLTRXS models will require separate purchase of Wiring Harness P/N 69201157.

53000238	Red Lens.	\$99.95
53000239	Smoked Lens.	\$99.95

LED REPLACEMENT LIGHT KITS

Fits Color-Matched Tour-Pak Spoiler or Saddlebag Spoiler on '94-'13 models.

68160-99	Tour-Pak Spoiler.	\$64.95
68192-99	Saddlebag Spoiler.	\$44.95

See page 811 for a complete list of available Color-Matched options.

*NOTE: This product is a "Paint to Order" accessory. Please allow for an average of 5 weeks delivery for this item.



A. COLOR-MATCHED SADDLEBAG LID SPOILER KIT – '14-LATER MODELS



A. COLOR-MATCHED SADDLEBAG LID SPOILER KIT – '93-'13 MODELS



B. COLOR-MATCHED TOUR-PAK SPOILER KITS – '14-LATER MODELS



B. COLOR-MATCHED TOUR-PAK SPOILER KITS – '93-'13 MODELS

TOURING & TRIKE 403

Saddlebag Accessories



C. ROAD KING CLASSIC LEATHER SADDLEBAG KIT

C. ROAD KING® CLASSIC LEATHER SADDLEBAG KIT

The perfect combination of style and function. These traditional leather saddlebags are a direct replacement for the Color-Matched Hard Saddlebags featured on the Road King® model and their installation transforms the look of your ride. The bags are formed from a leather-covered composite to hold its shape and feature embossed leather accents, a Road King Classic medallion and easy-open quick-release clips hidden behind traditional leather strap and chrome buckle closures. Kit includes left and right bags and reflectors.

90201079 **\$899.95**

Fits '14-later Road King models.

D. ROAD KING® SADDLEBAG LOCK SET

Add theft deterrence to your Road King® rigid leather saddlebags. Special order keyed-to-match lock set available. Contact your Dealer with your vehicle key code. Kit includes two keys.

46316-04 **\$279.95**

Fits '98-later Road King Classic models.

46287-04 **\$69.95**

Fits '04-'07 Road King Custom models.

E. TRIKE SADDLEBAGS

Add additional storage at your fingertips. These vinyl-wrapped rigid side bags are a perfect match to either the Original Equipment or accessory seats and are contoured to fit comfortably under the passenger's legs. Featuring an easy-to-grip chrome-plated Bar & Shield finger pull, the forward-opening bags snap shut with a strong magnetic closure. The interior can accommodate 2 soda cans or water bottles side by side and is the ideal spot for sunscreen, glasses and your cell phone. Luggage capacity: 700 cubic inches total.

84031-11 **\$419.95**

Fits '09-later FLHTCUTG and FLHXXX models.

F. SADDLEBAG EXTENSION KIT

Give your saddlebags the "tail dragger" look. Originally featured on the '09 CVO™ Road Glide®, these extensions visually stretch the saddlebags and wrap around the exhaust for a true "low rider" look. Manufactured from the same durable ABS material as the Original Equipment saddlebags, these primed extensions are ready to paint and attach to the saddlebag bottoms. No filler or re-painting of the Original Equipment bag is necessary. Finish the look with available Color-Matched Saddlebag Filler Strips (sold separately).

90999-09 **\$349.95**

Fits '04-'13 Touring models equipped with Color-Matched Hard Saddlebags.



D. ROAD KING SADDLEBAG LOCK SET



E. TRIKE SADDLEBAGS



F. SADDLEBAG EXTENSION KIT

Notice: The prices appearing in this catalog are the manufacturer's suggested retail prices. Actual retail prices may vary.

404 TOURING & TRIKE

Saddlebag Accessories

A. COLOR-MATCHED STRETCHED SADDLEBAG BOTTOMS*

Add the long low "slammed" look to your Touring bike without compromising the suspension travel and ride height. These Stretched Saddlebag Bottoms wrap around the exhaust to add visual length to the bike and hide the muffler bracket and hanger from view. The full-depth extended Saddlebag Bottoms add additional storage capacity and are manufactured of the same materials as the latest Original Equipment saddlebags for a glass-smooth painted surface. Available primed or factory-finished to match your Original Equipment painted finish. These Stretched Bottoms are pre-drilled to accept your existing saddlebag lids and latches. Simply attach the extended saddlebag bottom to your saddlebag lids with the included hardware and install on the bike like the original bags.

Available to fit:

Fits '14-later Touring models with Color-Matched Hard Saddlebags.

Fits '93-'13 Touring models with Color-Matched Hard Saddlebags.

See page 810 for a complete list of available Color-Matched options.



A. COLOR-MATCHED STRETCHED SADDLEBAG BOTTOMS – '14-LATER MODELS
(SHOWN WITH SADDLEBAG LID SPOILERS)



A. COLOR-MATCHED STRETCHED SADDLEBAG BOTTOMS – '93-'13 MODELS
(SHOWN WITH SADDLEBAG LID SPOILERS)

*NOTE: This product is a "Paint to Order" accessory. Please allow for an average of 5 weeks delivery for this item.

Notice: The prices appearing in this catalog are the manufacturer's suggested retail prices. Actual retail prices may vary.

TOURING & TRIKE 405

Saddlebag Accessories



B. COLOR-MATCHED SADDLEBAG FILLER STRIP KITS – SOLID ('14-LATER MODEL)



B. COLOR-MATCHED SADDLEBAG FILLER STRIP KITS – SLOTTED ('14-LATER MODEL)



B. COLOR-MATCHED SADDLEBAG FILLER STRIP KIT – SOLID ('09-'13 MODEL)



B. COLOR-MATCHED SADDLEBAG FILLER STRIP KIT – SLOTTED ('09-'13 MODEL)

B. COLOR-MATCHED SADDLEBAG FILLER STRIP KITS*

For those who seek perfection, these kits fill in the gaps between the fender and the rear of the saddlebags, hiding the saddlebag mounting bracket. Choose between primed, highly polished chrome or Color-Matched to your sheet metal and bags for a truly custom look.

Available to fit:

Solid

Fits '14-later Touring models with hard saddlebags. Does not fit with accessory Saddlebag Guard Rails. Does not fit Street Glide®, Road Glide®, Tri Glide® or Freewheeler™ models.

Slotted

Fits '14-later Touring models with hard saddlebags and accessory saddlebag guard rails. Does not fit Street Glide, Road Glide, Tri Glide or Freewheeler models.

Solid

Fits '09-'13 FLHT, FLHR and FLHTK models.

Slotted

Fits '09-'13 Touring models equipped with Nostalgic Saddlebag Rail P/N 91286-09 and 91286-10.

Solid

Fits '93-'08 Electra Glide® (except FLHX) models, '94-'08 FLHR models (except FLHRCI with rear docking kit and FLHRS) and '93 FLHS models. (Will not fit models equipped with Nostalgic and Triple Rail Saddlebag Guard Rails or chrome Saddlebag Guard Kit P/N 90839-93A, 91216-97; Electra Glo™ Light Rails; Leather Saddlebags P/N 90652-94A, 90843-93; or with Fender Rail P/N 91019-92A. Does not fit '98-'08 FLTR.)

Also available (not shown):

CHROME SADDLEBAG FILLER STRIP KIT

Fits '95-'08 Electra Glide (except FLHX), '94-'08 FLHR (except FLHRS) and '93 FLHS models equipped with Nostalgic Saddlebag Guard Rails P/N 90839-94; fits '98 FLHRCI with Nostalgic Saddlebag Guard Rails P/N 91265-98. (Will not fit models equipped with Leather Saddlebags P/N 90652-94A, 90843-93 or Fender Rail P/N 91019-92A. Will not fit '98-'08 FLHRCI with H-D® Detachables™ Docking Kit or '98-'08 FLTR.)

45896-98 Slotted.

\$109.95

See page 809 for a complete list of available Color-Matched options.

*NOTE: This product is a "Paint to Order" accessory. Please allow for an average of 5 weeks delivery for this item.

Notice: The prices appearing in this catalog are the manufacturer's suggested retail prices. Actual retail prices may vary.

406 TOURING & TRIKE

Saddlebag Guards

A. SADDLEBAG SUPPORT KIT

Complete the stripped-down look by eliminating the rear saddlebag guards. This kit replaces the Original Equipment loop saddlebag guard and support with an inconspicuous bolt-on bar that supports the saddlebag for a clean, custom appearance. Kit includes left and right support and all necessary mounting hardware.

90200981 **\$99.95**
Fits '14-later FLHR, FLHTCU, FLHTCUL, FLHTK, FLHTKL and FLHTKSE models. Stock on '14-later FLHRSE, FLHX, FLHXS, FLHXSE, FLTRUSE, FLTRX and FLTRXS models.

90881-09A **\$149.95**
Fits '09-'13 Touring models (except FLHRC and FLHTCUSE4/5/6/7/8). Stock on '09-'13 FLHX, FLTR, FLTRU, FLTRX, FLHRSE5, FLHXSE/2/3, FLTRSE3 and FLTRXSE/2 models. Does not fit with Saddlebag Filler Strip Kits.

46565-04 **\$149.95**
Fits '97-'08 Touring (except FLHRC) models. Stock on FLHRS, FLHX and '04-'08 FLTR models.



A. SADDLEBAG SUPPORT KIT ('14-LATER MODELS)

B. REAR SADDLEBAG GUARD AND SUPPORT KIT*

Add protection and style to your ride. Complete kit replaces the under-saddlebag support found on some Touring models with loop-style saddlebag guards for a traditional look. Featured as Original Equipment on many Touring models, these chrome-plated guards protect the leading edge of the saddlebag, and are shaped to accept Saddlebag Guard Bags (sold separately) for added storage. Kit includes saddlebag supports, left and right guards and all necessary mounting hardware.

90200787 Chrome. **\$229.95**
Fits '14-later FLHX, FLHXS, FLRTX, FLTRXS, FLTRUSE and FLHRSE models. Stock on '14-later FLHR, FLHRC, FLHTCU, FLHTCUL, FLHTK, FLHTKL and FLHTKSE models.

90200788 Gloss Black. **\$229.95**
Fits '14-later FLHX, FLHXS, FLRTX, FLTRXS, FLTRUSE and FLHRSE models.

49282-09B Chrome. **\$229.95**
Fits '09-'13 FLHX, FLTR, FLTRU, FLTRX, FLHRSE5, FLHXSE/2/3, FLTRSE3 and FLTRXSE/2 models.

49291-07 Chrome. **\$229.95**
Fits '04-'08 FLHRS, FLHX, FLTR and '05 FLHTCSE2 models.



A. SADDLEBAG SUPPORT KIT ('09-'13 MODELS)



B. REAR SADDLEBAG GUARD AND SUPPORT KIT – CHROME ('14-LATER MODELS)



B. REAR SADDLEBAG GUARD AND SUPPORT KIT – GLOSS BLACK '14-LATER MODELS



B. REAR SADDLEBAG GUARD AND SUPPORT KIT – CHROME '09-'13 MODELS



***WARNING:** These guards may provide limited leg and cosmetic vehicle protection under unique circumstances (fall over while stopped, very low speed slide). They are not made nor intended to provide protection from bodily injury in a collision with another vehicle or any other object.

Notice: The prices appearing in this catalog are the manufacturer's suggested retail prices. Actual retail prices may vary.

TOURING & TRIKE 407

Saddlebag Guards



C. REAR SADDLEBAG GUARDS – GLOSS BLACK ('14-LATER MODELS)



C. REAR SADDLEBAG GUARDS – GLOSS BLACK*

Add a sinister look to your ride. Designed to replace the Original Equipment chrome-plated guards featured on many Touring models, the blacked-out finish minimizes the look without a reduction in protection.

90200791 \$179.95

Fits '14-later FLHR, FLHRC, FLHTCU, FLHTCUL, FLHTK, FLHTKL and FLHTKSE models. Installation requires reuse of Original Equipment saddlebag supports.

49283-09 \$189.95

Fits '09-'13 Touring models. FLHX, FLTR, FLTRU, FLTRX, FLHRSE5, FLHXSE/2/3, FLTRSE3 and FLTRXSE/2 models require separate purchase of Saddlebag Supports P/N 49194-09A and 90781-09A, Nut P/N 7531 (Qty 2) and Antenna Mounting Bracket P/N 76516-09.

46548-03 \$189.95

Fits '97-'08 Touring models. ('04-'08 FLTR, FLHX and FLHRS models require the separate purchase of Saddlebag Supports P/N 49194-85 and 90781-93 and two P/N 3601 and 7686.)

D. COMFORT PROFILE REAR SADDLEBAG GUARD KIT*

The unique profile of these chrome-plated Rear Saddlebag Guards gives your passenger more leg room. A perfect replacement for the Original Equipment saddlebag guards.

49179-09 \$189.95

Fits '09-'13 Touring models (except FLHTC, FLHTCU and FLHTCUSE4/5/6/7/8). FLHX, FLTR, FLTRU, FLTRX, FLHRSE5, FLHXSE/2/3, FLTRSE3 and FLTRXSE/2 models require separate purchase of Saddlebag Supports P/N 49194-09A and 90781-09A, Nut P/N 7531 (Qty 2) and Antenna Mounting Bracket P/N 76516-09. FLHRC models require separate purchase of reflectors P/N 59370-98 and 59371-98.

49087-01 \$189.95

Fits '97-'08 FLHR, FLTR, FLHX and FLHT models. FLHRCI models require separate purchase of Reflector P/N 59370-98 and 59371-98. '04-'08 FLTR, FLHX and FLHRS models require separate purchase of Saddlebag Supports P/N 49194-85 and 90781-93 and two each of P/N 3601 and 7686. (Will not fit Saddlebag Guard Bags.)



C. REAR SADDLEBAG GUARDS – GLOSS BLACK ('09-'13 MODELS)



E. BILLET SADDLEBAG MOUNT BRACKET TRIM

Give the rider following you something to look at. This chrome-plated "ball-milled" billet bracket replaces the mounting bolts between the lower saddlebag rail and the fender, for a clean, custom look. Kit includes two brackets and required hardware.

90200666 \$69.95

Fits '09-'13 Touring models (except FLHX, FLHXSE/2/3, FLTRX and FLTRXSE/2). Does not fit with Saddlebag Guard Rails P/N 91179-10, 91286-10, or Saddlebag Filler Strip Kits.

91777-02 \$69.95

Fits '96-'08 Touring models (except FLHX). Does not fit with Saddlebag Guard Rails P/N 90839-04 or 91265-98, Filler Strip Kits P/N 45898-98, 45899-98, 45896-98 or 45897-98 or Active Exhaust Kit P/N 65467-05.



D. COMFORT PROFILE REAR SADDLEBAG GUARD KIT



E. BILLET SADDLEBAG MOUNT BRACKET TRIM ('96-'08 MODELS)



E. BILLET SADDLEBAG MOUNT BRACKET TRIM ('09-'13 MODELS)



***WARNING:** These guards may provide limited leg and cosmetic vehicle protection under unique circumstances (fall over while stopped, very low speed slide). They are not made nor intended to provide protection from bodily injury in a collision with another vehicle or any other object.

Notice: The prices appearing in this catalog are the manufacturer's suggested retail prices. Actual retail prices may vary.

408 TOURING & TRIKE

Saddlebag Rails

A. SADDLEBAG GUARD RAILS

Protect the sides and rear of your saddlebags from bumps and bruises. Saddlebag Guard Rails surround the lower portion of the bag, and add a traditional look to your Touring bike. The thick-walled chrome-plated tubing and the elegant cast mounts clamp securely to the Original Equipment saddlebag guards for a seamless look. The rails are pre-assembled to simplify installation, and the kit includes left and right rails and all required mounting hardware.

90200561 **\$289.95**

Fits '14-later Touring models (except FLHRC, FLHRSE, FLHX, FLHXS, FLTRX, FLTRXS and FLTRUSE). FLHTKSE models require separate purchase of Slotted Saddlebag Filler Strips.



**A. SADDLEBAG GUARD RAILS
(‘14-LATER MODELS)**

B. TWIN RAIL CHROME SADDLEBAG GUARD KIT

Kit comes with rear saddlebag guards, side rails, mounting hardware and instructions for easy installation.

90892-09 **\$339.95**

Fits '09-'13 FLHR, FLHT, FLHTK, FLTR and FLTRU models. Stock on '09-'13 FLHTC and FLHTCU models. FLTR and FLTRU models require separate purchase of Saddlebag Supports P/N 49194-09A, 90781-09A, Nut P/N 7531 (qty 2) and Antenna Mounting Bracket P/N 76516-09.

91216-97 **\$339.95**

Fits '97-'08 FLHT, FLHR, FLHTCUSE/2/3 and '98-'08 FLTR models. '04-'08 FLTR models require the separate purchase of Saddlebag Supports P/N 49194-85 and 90781-93, Nut P/N 7686 (Qty 2) and Screw P/N 3601 (Qty 2).



**B. TWIN RAIL CHROME SADDLEBAG GUARD KIT
(‘09-‘13 MODELS)**

C. NOSTALGIC SADDLEBAG GUARD RAILS

Forge a link with the Panhead era by easily bolting on these Nostalgic Saddlebag Guard Rails. The soft curves of the nostalgic twin tube design hug the shape of the bag for a custom look, and the sturdy welded steel tubing is hand-polished and chrome-plated for a sparkling finish.

91286-10 **\$239.95**

Fits '09-'13 FLHR, FLHT and FLHTK models. Also fits FLTR and FLTRU models with separate purchase of Chrome Saddlebag Guard Kit P/N 49282-09B.

90839-94A **\$239.95**

Fits '95-'08 FLHT Standard, '94-'08 FLHR and '93 FLHS models. (Does not fit FLHX, FLHRC and FLHRS.)

91179-10 **\$239.95**

Fits '09-'13 FLHRC models.

91265-98A **\$239.95**

Fits '98-'08 FLHRC/I models only.



C. NOSTALGIC SADDLEBAG GUARD RAILS – HARD SADDLEBAGS



C. NOSTALGIC SADDLEBAG GUARD RAILS – ROAD KING CLASSIC SADDLEBAGS

Notice: The prices appearing in this catalog are the manufacturer's suggested retail prices. Actual retail prices may vary.

TOURING & TRIKE 409

Saddlebag Rails



D. SADDLEBAG GUARD RAIL INSERTS

D. SADDLEBAG GUARD RAIL INSERTS

These ribbed trim panels nest between the saddlebag guard rails for a gleaming chrome accent. Styled to complement the raised rib design of Harley-Davidson® front fender skirts, engine/transmission interface covers and passenger foot-board covers, the Guard Rail Inserts complete a fender-to-fender customizing statement. Kit includes all necessary mounting hardware.

90251-09 \$144.95
Fits '09-'13 Electra Glide® Classic and Ultra Classic® models and models equipped with Twin Rail Saddlebag Guard Rails.

90206-02 \$144.95
Fits '93-'08 Electra Glide Classic and Ultra Classic, '98-'08 Road Glide®, '93-'96 Tour Glide™ Ultra Classic and '93-'08 Electra Glide Standard with Chrome Saddlebag Guard Kit P/N 90839-93A.

E. SKULL SADDLEBAG GUARD RAIL INSERTS

These ribbed trim panels with a chrome skull medallion nest between the saddlebag guard rails for a gleaming chrome accent. Styled to complement the Skull Collection front fender skirts, the Guard Rail Inserts complete a fender-to-fender customizing statement. Kit includes all necessary mounting hardware.

90255-09 \$144.95
Fits '09-'13 Electra Glide Classic and Ultra Classic models and models equipped with Twin Rail Saddlebag Guard Rails.

90214-05 \$144.95
Fits '93-'08 Electra Glide Classic and Ultra Classic, '98-'08 Road Glide, '93-'96 Tour Glide Ultra Classic and '93-'08 Electra Glide Standard with Chrome Saddlebag Guard Kit P/N 90839-93A.



E. SKULL SADDLEBAG GUARD RAIL INSERTS

F. ELECTRA GLO™ LIGHT RAILS

Molded housings incorporate wave-soldered circuit boards with tungsten filament bulbs for enhanced illumination. Precision-molded Lexan® polycarbonate lenses lined with light-diffusing panels offer consistent, even light dispersion. Assembled and wired for bolt-on and plug-in installation. Kit includes bracketry, hardware, and instructions.

68682-09 \$599.95
Fits '09-'13 Road King®, Street Glide® and Electra Glide models equipped with hard saddlebags. Installation on models not factory-equipped with saddlebag guards requires separate purchase of Saddlebag Guard Rail Kit P/N 90892-09.

90531-93 \$579.95
Fits '94-'08 FLTCU, FLHTCU, FLHTC and '98-'03 FLTR models. Will not fit '06-'08 FLHX models.

NOTE: Installation on '93 FLHS and '94-'96 FLHR models requires Saddlebag Guard Kit P/N 90839-93A. Installation on '97-later FLHT and FLHR (except '98-later FLHRC and FLHRS) models requires Saddlebag Guard Kit P/N 91216-97. Must be purchased separately. To install on '93-'96 models equipped with accessory Triple Saddlebag Rail Kit P/N 90845-93A, Left and Right Outer Guard Rail Clamps P/N 90919-93 and P/N 90917-93 are required and must be purchased separately.



F. ELECTRA GLO LIGHT RAILS

Notice: The prices appearing in this catalog are the manufacturer's suggested retail prices. Actual retail prices may vary.

410 TOURING & TRIKE

Saddlebag Lid Rails

A. TOURING SADDLEBAG LID RAILS

Protect your saddlebag lids from scratches and boot marks. Elegant welded rails are formed of high-quality tubing, and are beautifully polished and chrome plated to a mirror-like finish. The rails are shaped to wrap down the front of the saddlebag lid, and are designed to accept model-specific medallions (sold separately) for a custom touch. The three-point mount simplifies installation, and the complete kit includes left and right rails, and mounting hardware.

90200876 **\$139.95**
Fits '14-later Touring models with Color-Matched Hard Saddlebags.

90200737 **\$129.95**
Fits '93-'13 Touring models with Color-Matched Hard Saddlebags. Does not fit models with leather covered bags or models equipped with Saddlebag Wing Tips P/N 53826-00B.



A. TOURING SADDLEBAG LID RAILS

B. AIR WING SADDLEBAG LID RAIL KIT

The low-profile aerodynamic styling of the Air Wing Saddlebag Lid Rail enhances the look and protects the lid of your Color-Matched Hard Saddlebags. Available in mirror-chrome or gloss black finish, the rails cascade down the front of the saddlebag to protect the paint from a misplaced boot heel, and the die-cast wing design at the rear complements the style of the Air Wing Luggage Rack. Kit includes all necessary mounting hardware. For added visibility, add the available Air Wing Light Kit (sold separately).

Fits '14-later Touring models with Color-Matched Hard Saddlebags.

90200792 Chrome. **\$149.95**
90200793 Gloss Black. **\$149.95**

Fits '93-'13 Touring models with Color-Matched Hard Saddlebags. Does not fit models with leather covered bags or models equipped with Saddlebag Wing Tips P/N 53826-00B.

88299-09 Chrome. **\$139.95**
90200391 Gloss Black. **\$139.95**



B. AIR WING SADDLEBAG LID RAIL KIT – CHROME

C. AIR WING RAIL LED LIGHT KIT

Custom fit to the Air Wing Rails, this fast-acting LED Light Kit operates as a supplemental rear running light and brake light. The high and outside mounting position places the lights in the line-of-sight of following vehicles, and the bright, fast-acting LED lamps get you noticed. Wiring is concealed inside the rack tubes for a clean, custom installation.

Fits '14-later Touring models equipped with Air Wing Saddlebag Rails P/N 90200792 or 90200793.

68000115 Red. **\$79.95**
68000114 Smoked. **\$79.95**

Fits '93-'13 Touring models equipped with the Air Wing Saddlebag Lid Rails P/N 88299-09, 90200391 and '09-'13 Trike models equipped with Air Wing Trike Fender Rails P/N 61400058.

68286-10 Smoked. **\$79.95**
68388-10 Red. **\$79.95**



B. AIR WING SADDLEBAG LID RAIL KIT – GLOSS BLACK



C. AIR WING RAIL LED LIGHT KIT

Notice: The prices appearing in this catalog are the manufacturer's suggested retail prices. Actual retail prices may vary.

TOURING & TRIKE 411

Saddlebag Lid Rails



D. SADDLEBAG LID RAIL MEDALLIONS

D. SADDLEBAG LID RAIL MEDALLIONS

Personalize your ride. Mirror-chrome medallions fit between the forward-facing portions of the Touring Saddlebag Lid Rails or the Air Wing Saddlebag Lid Rails for a custom look. Model-specific script is deeply carved into the surface, and filled with a rich black finish for immediate identification. Chrome-plated installation bracket and stainless steel hardware mount from the back side for a clean, uncluttered look. Kit includes left and right medallion and all mounting hardware.

Fits '14-later Touring models equipped with Premium Saddlebag Lid Rails P/N 90200876 or Air Wing Saddlebag Lid Rails P/N 90200792 or 90200793.

90200954	Ultra.	\$36.95
90200951	Limited.	\$36.95
90200957	FLHX.	\$36.95

Fits '93-'13 Touring models equipped with Touring Saddlebag Lid Rails P/N 90200737 or Air Wing Saddlebag Lid Rails P/N 88299-09 or 90200391.

90200741	Ultra.	\$29.95
90200740	Limited.	\$29.95
90200742	FLHX.	\$29.95

E. AIR WING FENDER RAIL FOR TRIKE

The low-profile aerodynamic shape of the Air Wing Fender Rail enhances the look and protects the surface of your Trike's rear fenders. The mirror-chrome rails follow the sleek contours of the fenders, and the slim rails and die-cast rear wings complement the available Air Wing Tour-Pak® Luggage Rack. Kit includes left and right rail and all necessary mounting hardware.

61400058	Chrome.	\$169.95
-----------------	---------	-----------------

Fits '09-later FLHTCUTG and FLHXXX models. Does not fit with Trike Fender Bra P/N 57892-11.

Also available:

AIR WING RAIL LED LIGHT KIT

Custom fit to the Air Wing Rails, this fast-acting LED Light Kit operates as a supplemental rear running light and brake light. The high and outside mounting position places the lights in the line-of-sight of following vehicles, and the bright, fast-acting LED lamps get you noticed. Wiring is concealed inside the rack tubes for a clean, custom installation.

Fits '93-'13 Touring models equipped with the Air Wing Saddlebag Lid Rails P/N 88299-09, 90200391 and '09-'13 Trike models equipped with Air Wing Trike Fender Rails P/N 61400058.

68286-10	Smoked.	\$79.95
68388-10	Red.	\$79.95



E. AIR WING FENDER RAIL FOR TRIKE



E. AIR WING FENDER RAIL FOR TRIKE



E. AIR WING FENDER RAIL FOR TRIKE (SHOWN WITH AIR WING LIGHT KIT)

Notice: The prices appearing in this catalog are the manufacturer's suggested retail prices. Actual retail prices may vary.

412 TOURING & TRIKE

Saddlebag Accessories

A. BILLET SADDLEBAG HINGE COVER KIT – EDGE CUT

Dress your saddlebags in style. Edge Cut Saddlebag Hinge Covers feature a rich black finish that is machined to expose the highlights of raw aluminum. The contrasting cut-back look makes a powerful visual statement, and works great with both traditional and contemporary customizing styles. These covers replace the Original Equipment covers, but retain the stock hinges and locks for easy installation. Kit includes left and right covers, mounting hardware and saddlebag-mounted red reflectors.

90200915 **\$159.95**

Fits '14-later Touring models equipped with hard saddlebags. HDI models require separate purchase of amber Reflector P/N 59289-92 and 59290-92.

90200421 **\$139.95**

Fits '93-'13 Touring models equipped with hard saddlebags. HDI models require separate purchase of Reflector P/N 59289-92 and 59290-92.



**A. BILLET SADDLEBAG HINGE COVER KIT –
EDGE CUT
(90200915 SHOWN)**



**A. BILLET SADDLEBAG HINGE COVER KIT –
EDGE CUT
(90200421 SHOWN)**

B. BILLET SADDLEBAG HINGE COVER KIT – CHROME GROOVED

This sweep of chrome will set the tone for a very special Touring custom. Manufactured from billet aluminum, this polished and plated cover replaces the Original Equipment saddlebag hinge for a striking look. The grooved "ball-milled" design and curved leading and trailing edge add a feeling of forward motion, even while parked on Main Street. Kit includes chrome-plated mounting hardware and red saddlebag-mounted reflectors.

90201084 **\$159.95**

Fits '14-later Touring models equipped with hard saddlebags. HDI models require separate purchase of amber Reflector P/N 59289-92 and 59290-92.

90645-03A **\$139.95**

Fits '93-'13 Touring models equipped with hard saddlebags. HDI models require separate purchase of Reflector P/N 59289-92 and 59290-92.



**B. BILLET SADDLEBAG HINGE COVER KIT –
CHROME GROOVED
(90201084 SHOWN)**



**B. BILLET SADDLEBAG HINGE COVER KIT –
CHROME GROOVED
(90645-03A SHOWN)**

C. SADDLEBAG LATCH AND HINGE KIT – GLOSS BLACK

Gloss Black Saddlebag Hinge Covers and finger-operated Latches are an easy way to give your Touring bike a unique monochrome look. These latches add a dark custom touch to the motorcycles' s profile, and complement almost any paint combination. Easy to install with Original Equipment hardware and reflectors.

90200914 Latch Lever and Hinge Cover Kit. **\$194.95**

Fits '14-later Touring models equipped with hard saddlebags. Hinge Cover is standard equipment on FLHX models.

90201052 Latch Lever only. **\$74.95**

Fits '14-later Touring models equipped with hard saddlebags.



C. SADDLEBAG LATCH AND HINGE KIT – GLOSS BLACK



C. SADDLEBAG LATCH AND HINGE KIT – GLOSS BLACK

Notice: The prices appearing in this catalog are the manufacturer's suggested retail prices. Actual retail prices may vary.

TOURING & TRIKE 413

Saddlebag Accessories



D. SADDLEBAG LATCH KIT – THE BURST COLLECTION

D. SADDLEBAG LATCH KIT – THE BURST COLLECTION

Sculpted machining sends reflections of light in all directions. Latches feature a rich black anodized finish that is machined to expose the highlights of raw aluminum. The contrasting cut-back look makes a powerful visual statement, and works great with both traditional and contemporary customizing styles. These covers replace the Original Equipment latch covers, but retain the stock hinges and locks for easy installation. Kit includes left and right hinge covers, chrome plated mounting hardware and saddlebag-mounted reflectors.

90200821 **\$169.95**

Fits '93-'13 Touring models equipped with hard saddlebags. HDI models require separate purchase of Reflectors P/N 59289-92 and 59290-92.

E. BILLET SADDLEBAG LATCH KIT – MIDNIGHT FLAME

Styled to carry the "Flame" theme from front to back, this Flame Saddlebag Latch will get you noticed. The smooth black rubber insert is set into the brilliant chrome surface, defining the traditional "Hot Rod" flame pattern. The billet covers replace the Original Equipment latch covers, but retain the stock hinges and locks for easy installation. Kit includes chrome-plated mounting hardware and saddlebag-mounted reflectors.

90690-04A **\$159.95**

Fits '93-'13 Touring models equipped with hard saddlebags. HDI models require separate purchase of Reflector P/N 59289-92 and 59290-92.



E. BILLET SADDLEBAG LATCH KIT – MIDNIGHT FLAME

F. SADDLEBAG LATCH PLATE

Saddlebag Latch Plates are an easy way to give your Touring bike a unique monochrome look. Available in Vivid Black or Primed finish, these latches add a splash of color to the motorcycle profile. Easy to install with Original Equipment hardware.

Fits '93-'13 Touring models equipped with Color-Matched Hard Saddlebags. HDI models require separate purchase of Reflectors P/N 59289-92 and 59290-92.

91143-06BEO Primed. (pair) **\$84.95**

90853-06DH Vivid Black – Right Side. **\$49.95**

90857-06DH Vivid Black – Left Side. **\$49.95**

G. SADDLEBAG LID SPEAR TRIM KIT

These die-cast and chrome-plated trim spears add a sweeping slash of chrome to the saddlebag lid. Kit includes left and right trim strips, gaskets, mounting hardware and installation template.

53878-03 **\$84.95**

Fits '93-'13 Touring models equipped with Color-Matched hard saddlebags. Does not fit with Saddlebag Lid Speakers, Saddlebag Lid Rails, Lid Bra Kit P/N 57805-03 or previously installed Saddlebag Lid Organizer P/N 53548-02A.

H. SADDLEBAG WING TIPS

This chrome-plated steel trim is an ideal way to customize your saddlebag lids, and to protect the leading edge from road debris. Mounting hardware included. Sold in pairs.

53826-00B **\$74.95**

Fits '93-'13 Touring models equipped with Color-Matched Hard Saddlebags. (Does not fit with Saddlebag Rails except P/N 53662-87T.)

I. ROAD KING® CLASSIC SADDLEBAG TRIM

Chrome-plated, extruded and machined aluminum trim for saddlebag lid. Saddlebag trim complements the details of the Road King® fuel console. Includes four extruded trim spears and polished, stainless steel button head mounting hardware. Designed for use on the FLHRC leather saddlebags. Also looks great on Color-Matched hard bags.

53767-98 **\$134.95**

Fits '98-later Road King Classic models. Also fits '93-'13 models with H-D® Color-Matched Hard Saddlebags. Does not fit with Saddlebag Lid Speakers.



F. SADDLEBAG LATCH PLATE – VIVID BLACK



G. SADDLEBAG LID SPEAR TRIM KIT



H. SADDLEBAG WING TIPS



I. ROAD KING CLASSIC SADDLEBAG TRIM

TOURING

Notice: The prices appearing in this catalog are the manufacturer's suggested retail prices. Actual retail prices may vary.

414 TOURING & TRIKE

Saddlebag Lighting

A. ELECTRA GLO™ LED SADDLEBAG RUN/BRAKE/TURN LAMP*

Add functional lighting to the rear of your Touring bike. These running, directional and brake lights command the attention of following vehicles. The bright, fast-acting LED lamps glow red when the ignition is on, and intensify when the turn signals or brakes are activated. The lamps act as a supplement to the Tour-Pak® luggage mounted rear lighting. The lamps are housed in a low-profile chrome frame that is contoured to hug the curve of the hard saddlebags. The self-adhesive lamps fit seamlessly beneath the saddlebag lid and add a stylish touch of color, even when the bike is parked. Complete kit includes left and right lamps, modulator and quick-disconnect wiring harness.

Fits '14-later FLHTCU, FLHTCUL, FLHTK and FLHTKL models. Does not fit FLHTKSE.

67800241	Red Lens.	\$209.95
67800242	Smoked Lens.	\$209.95

Fits '14-later FLHX, FLHXS, FLTRX and FLTRXS models. Does not fit Canadian models.

67800448	Red Lens.	\$209.95
67800450	Smoked Lens.	\$209.95

Fits '14-later FLHR models with hard saddlebags. Also fits FLHTKSE, FLHRSE, FLTRUSE and Canadian FLHX, FLHXS, FLTRX and FLTRXS models.

67800449	Red Lens.	\$209.95
67800451	Smoked Lens.	\$209.95

B. ELECTRA GLO SADDLEBAG SIDE MARKER LIGHT KIT

This wrap-around Side Marker Light Kit adds a splash of light to the lower edge of the color-matched saddlebags. Available in your choice of red or smoked lens, the bright band of LED lamps is housed in a mirror chrome frame that hugs the bottom of the saddlebag. The low-profile self-adhesive Electra Glo™ lamps can be installed on models equipped with standard-length saddlebags, and are compatible with optional saddlebag guard rails. Easy to install kit includes left and right lamp and quick-disconnect wiring harness.

Fits '14-later Touring models with hard saddlebags. Not compatible with CVO™ or other models equipped with Stretched Saddlebags. Installation requires separate purchase of Electrical Connection Update Kit P/N 69200722.

68000082	Red Lens.	\$249.95
68000083	Smoked Lens.	\$249.95



A. ELECTRA GLO LED SADDLEBAG RUN/BRAKE/TURN LAMP



A. ELECTRA GLO LED SADDLEBAG RUN/BRAKE/TURN LAMP – SMOKED LENS



B. ELECTRA GLO SADDLEBAG SIDE MARKER LIGHT KIT – RED LENS



B. ELECTRA GLO SADDLEBAG SIDE MARKER LIGHT KIT – SMOKED LENS



B. ELECTRA GLO SADDLEBAG SIDE MARKER LIGHT KIT – RED AND SMOKED LENS



***WARNING:** Disconnecting your DOT requirement brake lamp could reduce your visibility to others and result in death or serious injury.

Notice: The prices appearing in this catalog are the manufacturer's suggested retail prices. Actual retail prices may vary.

TOURING & TRIKE 415

Luggage Accessories



C. SADDLEBAG GUARD BAG WITH WATER BOTTLE HOLDER – BAR & SHIELD LOGO ('14-LATER MODELS SHOWN)



C. BAG WITH WATER BOTTLE HOLDER – BAR & SHIELD LOGO ('93-'13 MODELS SHOWN)



C. BAG WITH WATER BOTTLE HOLDER – ROAD KING CLASSIC CONCHO ('93-'13 MODELS SHOWN)



D. SADDLEBAG GUARD BAG – BAR & SHIELD LOGO ('14-LATER MODELS SHOWN)



D. SADDLEBAG GUARD BAG – BAR & SHIELD LOGO ('93-'13 MODELS SHOWN)



D. SADDLEBAG GUARD BAG – ROAD KING CLASSIC CONCHO ('93-'13 MODELS SHOWN)

C. SADDLEBAG GUARD BAG WITH WATER BOTTLE HOLDER

Convenient on-the-go storage. Sturdy synthetic leather bags snap to the saddlebag guards for easy access. The storage compartment features a hook-and-loop outer flap and a zippered inner closure to store sunglasses, wallets and cell phones, and the adjoining sleeve securely grips a removable water bottle to help keep you hydrated on the road.

Bar & Shield Logo

Fits '93-later Touring models equipped with Saddlebag Guards.

93300060	Right Side.	\$79.95
93300061	Left Side.	\$79.95

Road King® Classic Concho

Fits '93-'13 Touring models equipped with saddlebag guard rails. Does not fit Comfort Profile Guard Rails.

92137-05	Left Side.	\$84.95
92136-05	Right Side.	\$84.95

D. SADDLEBAG GUARD BAG

Keep your essentials close at hand. Bags are constructed of sturdy synthetic leather, with a hook-and-loop flap covers a dual zippered opening that provides easy access to the interior. A separate internal zippered soft pouch is perfect for storing smaller items or sunglasses. Synthetic leather bags snap tightly to the saddlebag guard.

Bar & Shield Logo

Fits '93-later Touring models equipped with Saddlebag Guards.

93300062	Right Side.	\$79.95
93300063	Left Side.	\$79.95

Road King Classic Concho

Fits '93-'13 Touring models equipped with saddlebag guard rails. Does not fit Comfort Profile Guard Rails.

91219-98	Left Side.	\$84.95
91220-98	Right Side.	\$84.95

416 TOURING & TRIKE

Luggage Accessories

A. PREMIUM TOUR-PAK® FITTED LINING

Line your Touring bike's luggage to protect your belongings and reduce noise and rattles on the road. Soft-touch felt-finish liner is formed to the interior for a perfect fit. Molded base and sides maximize the interior room, and one-piece design allows easy removal for cleaning and maintenance.

53301-06 King Ultra Tour-Pak® **\$89.95**
Fits '93-'13 Touring and Trike models equipped with King Tour-Pak luggage with incandescent wrap-around Tail Lamp Kit. Does not fit '10-later CVO™ Touring models, FLHTK or models with Tour-Pak bottom tub mounted accessories.

53302-07 King Classic Tour-Pak. (not shown) **\$89.95**
Fits '93-'13 Touring and Trike models equipped with King Tour-Pak luggage without incandescent wrap-around Tail Lamp Kit. Does not fit with Tour-Pak bottom tub mounted accessories.

53000322 Chopped Tour-Pak. **\$79.95**
Fits '14-later Touring and Trike models equipped with Chopped Tour-Pak luggage. Does not fit with Tour-Pak bottom tub mounted accessories.

53000323 King Tour-Pak. **\$89.95**
Fits '14-later Touring and Trike models equipped with King Tour-Pak luggage.

53285-06 Chopped Tour-Pak. **\$79.95**
Fits '13-earlier Touring and Trike models equipped with Chopped Tour-Pak luggage. Does not fit with Tour-Pak bottom tub mounted accessories.

B. PREMIUM FITTED SADDLEBAG LINING

Protect your belongings and reduce noise and rattles on the road. Premium soft-touch felt-finish liner is formed to the hard saddlebag interior for a perfect fit. Molded base and sides maximize the interior room, and one-piece design allows easy removal for cleaning and maintenance.

90200918 **\$189.95**
Fits '14-later Touring models equipped with Color-Matched Hard Saddlebags. Does not fit Police model saddlebags.

92189-06 **\$159.95**
Fits '93-'13 Touring models equipped with Original Equipment Color-Matched Hard Saddlebags. Does not fit Police model saddlebags.



A. PREMIUM TOUR-PAK FITTED LINING – KING ULTRA '93-'13 MODELS



A. PREMIUM TOUR-PAK FITTED LINING – KING '14-LATER MODELS



A. PREMIUM TOUR-PAK FITTED LINING – CHOPPED '14-LATER MODELS



A. PREMIUM TOUR-PAK FITTED LINING – CHOPPED '13-EARLIER MODELS



B. PREMIUM FITTED SADDLEBAG LINING – '14-LATER MODELS



B. PREMIUM FITTED SADDLEBAG LINING – '93-'13 MODELS

Notice: The prices appearing in this catalog are the manufacturer's suggested retail prices. Actual retail prices may vary.

TOURING & TRIKE 417

Luggage Accessories



C. TOUR-PAK LID FITTED LINING WITH ORGANIZER – PREMIUM BLACK



C. TOUR-PAK® LID FITTED LINING WITH ORGANIZER – PREMIUM BLACK

Equip the Tour-Pak® lid to protect and store your belongings. This Premium Lid Lining features a soft-touch black felt finish to reduce noise, and a convenient series of storage pouches that provide easy access to all your essentials. Four flap pouches, and one mesh and one clear pocket provide plenty of storage and a great way to keep keys, cell phones, glasses, and papers handy. Hook-and-loop fasteners secure the one-piece formed lining to the lid, and allow easy removal for cleaning and maintenance.

53000392 \$159.95

Fits '14-later Touring and Trike models equipped with King or Chopped Tour-Pak luggage.



D. TOUR-PAK LID ORGANIZER/LINER – GRAY



D. TOUR-PAK LID FITTED LINING WITH ORGANIZER – GRAY

Add practical storage to your Tour-Pak luggage. This Lid Lining features a convenient six pocket organizer to keep smaller items conveniently at hand, and is shaped to fit the contours of the Tour-Pak lid for a finished look. The organizer features 4 enclosed pouches, 1 mesh pouch and 1 clear mobile-device pouch. The soft gray finish is the perfect match for the Original Equipment Tour-Pak bottom liner, and the hook-and-loop fasteners permit easy removal for cleaning.

53000302 \$134.95

Fits '14-later Touring and Trike models equipped with King or Chopped Tour-Pak luggage.



E. TOUR-PAK LID ORGANIZER – COLOR-MATCHED TOUR-PAK



E. TOUR-PAK LID ORGANIZER – LEATHER TOUR-PAK

E. TOUR-PAK LID ORGANIZER

A true innovation in storage convenience and efficiency, this ingenious lid organizer helps keep smaller items conveniently located under your Tour-Pak lid for easy access. The organizer features five different-sized nylon-meshed pockets, as well as two flaps for additional storage. A great way to keep keys, cell phones, glasses, and papers handy.

53249-01B \$94.95

Fits '93-'13 Touring and Trike models equipped with a King, Ultra, Chopped or Razor-Pak Tour-Pak. Does not fit '08-later CVO™ Ultra models with Power Locks, or models equipped with Tour-Pak Spoiler Kit P/N 53149-series, Tour-Pak Light P/N 54302-98A, Mini Tour-Pak Lid Rack P/N 53100-96 or Contoured Tour-Pak Luggage Rack P/N 79148-06.

54011-04 \$89.95

Fits '96-'13 XL, Softail® and Touring models equipped with Leather or Synthetic Leather Tour-Pak luggage (except 79189-06). Does not fit with Tour-Pak Luggage Racks, Interior Light Kits or Lock Kits.

F. SADDLEBAG LID ORGANIZER

Convenient storage underneath the saddlebag lids with four easy access compartments for small items. Styled to match the Tour-Pak Lid Organizer, these easy-to-install accessories include an embroidered "Harley-Davidson" script. Sold in pairs.

53548-02A Hard Saddlebags. \$84.95

Fits '93-'13 Touring models equipped with Color-Matched Hard Saddlebags. Does not fit with hard saddlebags on Police models, saddlebag lid rails and saddlebag lid trim kits.

54008-04 Leather Saddlebags. \$84.95

Fits Touring models equipped with FLHRC saddlebags.



F. SADDLEBAG LID ORGANIZER – COLOR-MATCHED HARD SADDLEBAGS



F. SADDLEBAG LID ORGANIZER – LEATHER SADDLEBAGS

TOURING

Notice: The prices appearing in this catalog are the manufacturer's suggested retail prices. Actual retail prices may vary.

418 TOURING & TRIKE

Luggage Accessories

A. TOUR-PAK® WALL ORGANIZER

Convenient storage system wraps the interior walls of your King Tour-Pak® for easy access to keys, cell phones, maps, and gloves. The organizer features a variety of mesh and enclosed pockets, sized perfectly to keep small items close at hand. Easily installed with included hook-and-loop tabs.

53000303 **\$99.95**

Fits '14-later Touring and Trike models equipped with King Tour-Pak luggage.

54014-05 **\$89.95**

Fits '93-'13 Touring and Trike models equipped with Ultra or King Tour-Pak luggage. Does not fit with Chopped or Razor-Pak Tour-Pak.



A. TOUR-PAK WALL ORGANIZER – '14-LATER MODELS

B. SADDLEBAG WALL ORGANIZER

Convenient storage system equips the interior wall of your Color-Matched Saddlebags for easy access to keys, cell phones, maps, and gloves. The organizer features a combination of mesh and enclosed pouches and pockets that are sized for safe, rattle-free packing. The organizer features a rigid backing that easily attaches to the wall of the saddlebag with the Original Equipment quick-release saddlebag fasteners. Kit includes left- and right-hand organizer.

90200882 **\$99.95**

Fits '14-later Touring models equipped with Color-Matched Hard Saddlebags.

88232-06 **\$54.95**

Fits '93-'13 Touring models equipped with Hard Saddlebags.



A. TOUR-PAK WALL ORGANIZER – '93-'13 MODELS

C. SADDLEBAG TOOL TETHER

A great way to bring along tools, spark plugs, and other small items, this unique Tool Tether replaces the saddlebag check strap. The hook-and-loop flaps lock the tools in place and help keep your saddlebag organized. Tools not included.

53579-01 **\$34.95**

Fits '93-'13 Touring models equipped with Color-Matched Hard Saddlebags.



B. SADDLEBAG WALL ORGANIZER – ('14-LATER MODELS SHOWN)

D. TRUNK DOOR ORGANIZER

For on-the-road storage and efficiency, this ingenious organizer helps keep smaller items conveniently located on your trunk door for easy access. The easy-to-install self-adhesive organizer features two large nylon-mesh pockets with hook-and-loop-secured flaps that offer quick access to keys, cell phones, glasses, gloves, and maps. Organizer features an embossed "Harley-Davidson" script logo. Add the matching Tour-Pak Lid Organizer P/N 53249-01B inside the Tour-Pak luggage for maximum organization.

93300001 **\$59.95**

Fits '09-later FLHTCUTG and FLHXXX models.



C. SADDLEBAG TOOL TETHER

D. TRUNK DOOR ORGANIZER

Notice: The prices appearing in this catalog are the manufacturer's suggested retail prices. Actual retail prices may vary.

TOURING & TRIKE 419

Luggage Accessories



E. PREMIUM TRAVEL-PAK – KING TOUR-PAK



**E. PREMIUM TRAVEL-PAK –
CHOPPED TOUR-PAK**



**E. PREMIUM TRAVEL-PAK –
HARD SADDLEBAGS**



**F. TRAVEL-PAK – '93-'13
KING TOUR-PAK**



**F. TRAVEL-PAK –
'94-'13 HARD SADDLEBAGS**



F. TRAVEL-PAK – LEATHER TOUR-PAK



**F. TRAVEL-PAK –
LEATHER SADDLEBAGS**

E. PREMIUM TRAVEL-PAKS

This collection of fitted luggage provides convenient storage for your next long ride. The bags are manufactured of water resistant ballistic nylon that matches the premium luggage collection. The exterior features comfortable carrying handles, heavy-duty glove-friendly zippers, a zippered pocket, D-rings for optional carrying straps. The padded interior features a variety of convenient storage pockets and plenty of open storage. Saddlebag right-hand bag features an internal padded laptop pocket and plenty of smart storage spaces.

93300072 King Tour-Pak®. **\$99.95**

Fits '93-later Touring and Trike models equipped with King Tour-Pak luggage.

93300071 Chopped Tour-Pak. **\$89.95**

Fits '93-later Touring and Trike models equipped with Chopped Tour-Pak luggage.

93300070 Hard Saddlebags. **\$129.95**

Fits '93-later Touring models equipped with Hard Saddlebags. Sold in pairs.

F. TRAVEL-PAKS

Simplify packing and unpacking your motorcycle. These well-constructed, water-resistant bags are designed to fit perfectly into Touring model luggage systems. The soft sides conform to the interior of the luggage to help use every available inch of space. Styled with a Bar & Shield logo, they feature heavy-duty zippers and convenient carrying handles.

53605-97 King Tour-Pak. **\$59.95**

Fits '93-later Touring and Trike models equipped with King and Ultra Tour-Pak luggage.

91783-96 Chopped Tour-Pak. (not shown) **\$54.95**

Fits '97-later Touring and Trike models equipped with Chopped Tour-Pak luggage.

91885-97A Hard Saddlebags. **\$59.95**

Fits '93-later Touring models equipped with Color-Matched Hard Saddlebags and '09-later VRSCF models equipped with Rigid Saddlebags P/N 91172-09. Sold in pairs.

53621-98 Leather Tour-Pak. **\$49.95**

Fits '96-'13 XL, Softail® Touring models equipped with Leather Tour-Pak luggage.

91887-98 Leather Saddlebags. **\$59.95**

Fits '98-later FLHRC and FLHRS models. Sold in pairs.

Notice: The prices appearing in this catalog are the manufacturer's suggested retail prices. Actual retail prices may vary.

420 TOURING & TRIKE

Luggage Accessories

A. TRUNK TRAVEL-PAKS

These well-constructed, ballistic nylon bags are designed to fit perfectly into the rear or top-load trunk of the Harley-Davidson® Trike models. Styled to compliment the Premium Luggage Collection, the twin bags feature white piping and a reflective Bar & Shield logo. The bags feature glove-friendly zippered access to the main compartment and convenient outer pouches. Comfortable carrying straps make transportation a breeze. Sold in pairs.

53000431 **\$114.95**
Fits '09-later FLHTCUTG, '10-'11 FLHXXX and '15-later FLRT models.



A. TRUNK TRAVEL-PAKS



A. TRUNK TRAVEL-PAKS

B. RIDER BRIEFCASE

Commute to work in style. Leather and vinyl briefcase is designed with the rider in mind, and is sized to fit effortlessly into hard saddlebags on Touring models. The oversized handle and the non-slip shoulder strap are comfortable to carry, and glove-friendly zippers and are easy to operate. The large messenger-style flap is secured with quick-release snaps concealed behind the traditional straps and buckles. When open, the interior reveals a zippered front storage pouch that features a key ring holder, secure cellphone pocket, a PDA accessory pocket, pen loops, interior zippered pocket and card holders. The main compartment features a padded laptop and tablet pocket and open storage for files and documents. Snap close side ports allow headphone and charger cable access. Size: 16.5" X 11.5" X 5.0", fits laptops up to 15.0" X 10.0" (accommodates most 17.0" screens).

93300092 **\$249.95**
Sized to fit Touring models equipped with Color-Matched Hard Saddlebags.



A. TRUNK TRAVEL-PAKS

C. SADDLEBAG COOLER

Keep beverages and snacks cold right in your saddlebag on those hot summer rides. This zippered bag is fully lined and insulated, and fits the full length of your saddlebag.

90200991 **\$69.95**
Fits '93-later Touring models equipped with Color-Matched Hard Saddlebags.



B. RIDER BRIEFCASE



C. SADDLEBAG COOLER

Notice: The prices appearing in this catalog are the manufacturer's suggested retail prices. Actual retail prices may vary.

TOURING & TRIKE 421

Paint Protection

NEW



**D. SADDLEBAG LID BRA
(90200992 SHOWN)**



**D. SADDLEBAG LID BRA
(57805-03A SHOWN)**

D. SADDLEBAG LID BRA

Protect your saddlebags from boot scuffs, stone chips and road debris. These custom-fit Saddlebag Lid Bras are made with non-abrasive, fleece-backed vinyl material and feature small Bar & Shield logos. Easy to install with hook-and-loop tabs. Kit includes left and right side Lid Bras.

90200992 **\$89.95**

Fits '14-later Touring models with Color-Matched Hard Saddlebags. Does not fit with Saddlebag Lid Rails, Saddlebag Lid Spoilers or Saddlebag Lid Speakers.

D. SADDLEBAG LID BRA

Protect your Original Equipment hard saddlebags from scratches and road debris. The Saddlebag Lid Bra is made with non-abrasive, fleece-backed vinyl material and features an embroidered Bar & Shield logo. Easy to install with hook-and-loop tabs. Kit includes left and right side Lid Bra.

57805-03A **\$89.95**

Fits '93-'13 Touring models equipped with Color-Matched Hard Saddlebags. Does not fit with Police Model Hard Saddlebags, Saddlebag Lid Rails, Saddlebag Lid Spoilers, or Saddlebag Wing Tips.

E. TOUR-PAK LID BRA

Protect your Razor-Pak, Chopped or King Tour-Pak® luggage from scratches and road debris. The Tour-Pak Lid Bra is made with non-abrasive fleece-backed vinyl material and features an embroidered Bar & Shield logo. Easy to install with hook-and-loop tabs.

57844-05 **\$99.95**

Fits '96-'13 models equipped with Razor-Pak, Chopped Tour-Pak and King Tour-Pak luggage. Does not fit with Tour-Pak Lid Racks, Tour-Pak Lid Spoilers or Tour-Pak Interior Light Kits.

F. TRIKE REAR FENDER BRA

Protect your Trike's rear fenders from boot scuffs and road debris. These rich black Fender Bras are constructed of non-abrasive fleece-backed smooth vinyl, and are simple to install. Featuring a prominent embossed Bar & Shield logo, these Bras are styled to coordinate with the matching Fairing Bra P/N 57800-00 and the Tour-Pak Lid Bra P/N 57844-05.

57892-11 **\$99.95**

Fits '09-later FLHTCUTG and '10-'11 FLHXXX models. Not for use with Chrome Fender Trim Kit P/N 83812-09.

G. SCUFF GUARDS

Guard against heel marks and stone chips on the leading edges of the rear fender and body of your Trike model. These heavy-duty molded rubber pads are shaped to match the contour of the body, and are easy to install with the pre-applied adhesive. The ribbed surface pattern mirrors the Original Equipment footboard inserts, and offers a clean, smooth-flowing look between the footboards and body.

Fits '09-later FLHTCUTG and '10-'11 FLHXXX models.

1. 83968-10 Body Scuff Guards. **\$29.95**

2. 83976-10 Fender Scuff Guards. **\$39.95**



E. TOUR-PAK LID BRA



F. TRIKE REAR FENDER BRA



G. SCUFF GUARDS — BODY & FENDER



G. SCUFF GUARDS — FENDER



G. SCUFF GUARDS — BODY

Notice: The prices appearing in this catalog are the manufacturer's suggested retail prices. Actual retail prices may vary.

422 TOURING & TRIKE

Paint Protection

TRANSPARENT PAINT GUARD KITS

This transparent skin is designed to protect your paint from bugs, boot scuffs and road debris. The crystal-clear material protects the paint without changing the overall look of your bike. And the optical properties of the material disguise minor scuffs and scratches. The application process is similar to that of tinted window film and the material can be removed and replaced when it is no longer cosmetically appealing. Scratches to paint can be expensive to repair but scratches to this film can be removed by applying a small amount of heat with a heat gun.

A. SADDLEBAGS – LID

11100098 **\$79.95**

Fits '14-later Touring models with Color-Matched Hard Saddlebags. Does not fit models with leather-covered bags, or Boom!™ Audio Speaker Lids. Not recommended for use on denim or aftermarket paint.

11100028A **\$79.95**

Fits '93-'13 Touring models with Color-Matched Hard Saddlebags. Does not fit models with leather-covered bags. Do not use with denim or aftermarket paint.

B. SADDLEBAGS – FRONT

11100097 **\$49.95**

Fits '14-later Touring models with Color-Matched Hard Saddlebags. Does not fit models with leather-covered bags. Not recommended for use on denim or aftermarket paint.

11100082 **\$49.95**

Fits '93-'13 Touring models with Color-Matched Hard Saddlebags. Not recommended for use on denim or aftermarket paint.

C. TOURING SIDE COVERS

11100078 **\$39.95**

Fits '97-later Touring models. Not recommended for use on denim or aftermarket paint.

D. FRONT FENDER

11100080 **\$39.95**

Fits Dyna® FLD, most FL Softail® (except Springer™) and Touring models. Not recommended for use on denim or aftermarket paint.

E. FAIRING LOWERS

11100086 **\$49.95**

Fits '83-'13 Touring (except '98-'09 FLTR) and Trike equipped with Vented Fairing Lower. Not recommended for use on denim or aftermarket paint.



A. TRANSPARENT PAINT GUARD KITS, SADDLEBAGS – LID



A. TRANSPARENT PAINT GUARD KITS, SADDLEBAGS – LID '93-'13 MODELS



A. TRANSPARENT PAINT GUARD KITS, SADDLEBAGS – LID '14-LATER MODELS



B. TRANSPARENT PAINT GUARD KITS, SADDLEBAGS – FRONT



C. TRANSPARENT PAINT GUARD KITS – TOURING SIDE COVERS



D. TRANSPARENT PAINT GUARD KITS – FRONT FENDER



E. TRANSPARENT PAINT GUARD KITS – FAIRING LOWERS

Notice: The prices appearing in this catalog are the manufacturer's suggested retail prices. Actual retail prices may vary.

TOURING & TRIKE 423

Paint Protection

NEW



F. TRANSPARENT PAINT GUARD KIT
(83989-10A SHOWN)



F. TRANSPARENT PAINT GUARD KIT
(11100125 SHOWN)

F. TRANSPARENT PAINT GUARD KIT – TRIKE

This transparent skin is designed to protect parts of the Trike bodywork from boot scuffs and road debris. The crystal-clear material protects the area surrounding the passenger foot-board and are pre-cut to fit the leading and inner surface of the rear fender, the fascia panel of the trunk and the side covers. Scratches in the material can be "healed" by applying a small amount of heat with a heat gun. The application process is similar to that of tinted window film and the material can be removed and replaced when it is no longer cosmetically appealing.

83989-10A **\$134.95**

Fits '09-later FLHTCUTG and '10-'11 FLHXXX models. Not recommended for use on denim or aftermarket paint.

11100125 **\$134.95**

Fits '15-later FLRT models. Not recommended for use on denim or aftermarket paint.

G. FAIRING BRA – BAT WING FAIRING

Offering a custom look and protection from the elements for your fairing, this Fairing Bra is made with non-abrasive, fleece-backed vinyl material and features a Bar & Shield logo. It is designed for easy installation and a custom fit.

57000307 **\$109.95**

Fits '14-later Electra Glide®, Street Glide® and Tri Glide® models.

57800-00 **\$109.95**

Fits '96-'13 Electra Glide, Street Glide and Trike models. Requires separate purchase of Chrome Windshield Molding P/N 59213-96.

H. FAIRING BRA – ROAD GLIDE®

With a custom fit and an embossed Bar & Shield logo, this fleece-lined vinyl Fairing Bra protects your Road Glide® fairing from the elements with a touch of style. Designed for easy installation, this one-piece Fairing Bra helps protect your paint from stone chips and bug residue.

57846-01 Fits '98-'13 Road Glide models. **\$124.95**

NEW



G. FAIRING BRA – BAT WING FAIRING
(57000307 SHOWN)



G. FAIRING BRA – BAT WING FAIRING
(57800-00 SHOWN)



H. FAIRING BRA – ROAD GLIDE

Notice: The prices appearing in this catalog are the manufacturer's suggested retail prices. Actual retail prices may vary.

424 TOURING & TRIKE

Electrical Accessories

A. CIGARETTE LIGHTER AND SOCKET KIT

Need a light? This complete kit is designed as a direct replacement for stock fairing mounted 12V accessory outlet. Kit includes heat-resistant fairing mounted receptacle, short knob pop out lighter with weather skirt and wire connectors. Not intended to be used as an accessory power outlet.

69200605 **\$29.95**
Fits '14-later Touring and Tri Glide® models equipped with fairing mounted 12V accessory outlet.



A. CIGARETTE LIGHTER AND SOCKET KIT

B. AUXILIARY POWER PORT

Power your cell phone, GPS, portable music player or tire inflator from this handy 12-volt power port. Conventional style power outlet accepts most 12V automotive power adaptor plugs, and features a flip-top cover to protect the port while not in use.

69200826 **\$40.95** Tour-Pak® Mount.
Fits '14-later FLHTCU, FLHTCUL and FLHTCUTG models. Original Equipment on FLHTK and FLHTKL.

91671-10 **\$49.95** Tour-Pak Mount.
Fits '96-'13 FLHTCU and '06-'13 FLHTC, FLTRU and FLHTCUTG models. Also fits '06-'13 Touring models with accessory King Tour-Pak luggage and '98-'13 Touring models with Tour-Pak mounted rear speaker pods. Not for use with Accessory Fitted Liners or Premier Liner.

69200091 **\$40.95** Saddlebag Mount.
Fits models equipped with 12-volt battery. Does not fit VRSC™ models, throw-over style saddlebags or swingarm bags. Not for use with accessory Fitted Liners or Premier Liner. Requires separate purchase of Battery Charging Harness P/N 94624-97B, if not already equipped.

91843-97 **\$29.95** Side-Panel Mount.
Fits '94-'13 Touring and Trike models.

69201099 **\$29.95** Side-Panel Mount.
Fits '14-later Touring and Trike models.



B. AUXILIARY POWER PORT – TOUR-PAK MOUNT

C. USB CHARGING ADAPTOR

Charge your cell phone, MP3 players, and other hand-held devices while on the road. Compact Adaptor plugs into standard or accessory 12-volt power ports, and provides a standard USB-style outlet that accepts many phone and music player power cords.

69200357 **\$19.95**
For use with 12V Auxiliary Power Port.



B. AUXILIARY POWER PORT – SADDLEBAG MOUNT



B. AUXILIARY POWER PORT – SIDE-PANEL MOUNT



C. USB CHARGING ADAPTOR

Notice: The prices appearing in this catalog are the manufacturer's suggested retail prices. Actual retail prices may vary.

TOURING & TRIKE 425

Electrical Accessories



D. 54-AMP HIGH OUTPUT CHARGING SYSTEM

D. 54-AMP HIGH OUTPUT CHARGING SYSTEM

The Harley-Davidson® High Output Charging System is engineered to provide 30% more power than the stock system at idle. With 54 amps of output at 4000 rpm, accessories will operate at their peak performance – no more dimming lights, reduced audio performance or under-performing heated gear. This is a recommended installation anytime a multi-amp audio system is installed on the vehicle in order to achieve the full capability of your audio system. It is also recommended when installing heated seats, heated gear and other higher draw powered accessories.

Stock on select CVO™ Touring models, the complete kit includes high performance rotor, stator, voltage regulator and all gaskets and hardware required for installation.

29900028 **\$489.95**
Fits '11-later Touring, '10-later CVO Touring and '09-later Trike models. Stock on '14-later FLHTKSE, FLTRUSE and FLHXSE.



E. 45-AMP CHARGING SYSTEM FOR ELECTRA GLIDE MODELS

E. 45-AMP CHARGING SYSTEM FOR ELECTRA GLIDE® MODELS

Standard equipment on H-D® Touring-style Police motorcycles, this high-output charging system knows how to work for a living. Add more electronics – including lights – on your Electra Glide® model without worrying about whether you've got the juice to back it up.

29999-97B Fits '99-'05 FLHT models. **\$269.95**



F. 32-AMP HIGH-OUTPUT ALTERNATOR KIT

F. 32-AMP HIGH-OUTPUT ALTERNATOR KIT

Stock on all '89-later carbureted 1340 models. 50% increase in amperage for the heavily accessorized motorcycle.

29985-87 **\$249.95**
Fits '84-'88 FLT, FLHT, and FXR (wet clutch) models. (Will not fit '84-'88 Softail®.) Stock on all '89-'95 and some '96-'97 Evolution® 1340-equipped models.



NEW

G. AUXILIARY POWER SWITCH KIT – FAIRING MOUNT (71400106 SHOWN)

G. AUXILIARY POWER SWITCH KIT – FAIRING MOUNT

Styled to match the Original Equipment fairing dash panel switches. These Auxiliary Power switches allow you to control additional fog lamps, auxiliary lighting, heated gear or electrical accessories with the touch of a finger. Kit includes two auxiliary switches, wire harnesses and installation hardware.

71400106 **\$79.95**
Fits '14-later Electra Glide and Tri Glide® models.



NEW

H. ELECTRICAL CONNECTION UPDATE KIT – TOURING

Harness plugs into accessory connector to provide 12-volt power leads. Required to install Heated Grips, XM Radio, Cruiser Amp & Speaker Systems, zūmo® GPS, Digital Oil Pressure Gauge, Garage Door Opener Kits, Heated Seats and decorative lighting on '14-later Touring and Trike models.

69200722 **\$23.95**
Fits '14-later Touring and Trike models.

I. SWITCHED CIRCUIT ADAPTER HARNESS

This harness allows two accessories to be connected to the switched accessory circuit featured on '94-later Touring models. You then may switch two accessories on or off simultaneously as required.

70264-94A **\$19.95**
Fits '94-later Touring and Trike models. Required on '14-later Touring and Trike models when connecting multiple powered accessories using Electrical Connection Kit P/N 69200722.



H. ELECTRICAL CONNECTION UPDATE KIT – TOURING



70264-94A

70270-04

I. SWITCHED CIRCUIT ADAPTER HARNESS & ELECTRICAL ACCESSORY ADAPTER

Also available:

ELECTRICAL ACCESSORY ADAPTER

Harness accommodates the addition of multiple electrical accessories to the main battery power circuit on specified models.

70270-04 **\$15.95**
Fits '04-'13 XL, XR and Touring and Trike models. Also fits '07-later VRSC™, '04-'11 Dyna® and '04-'10 Softail® models.

Notice: The prices appearing in this catalog are the manufacturer's suggested retail prices. Actual retail prices may vary.

NEVER IN A TIGHT SPOT

On the road, you've got to feel good in the saddle. Whether you're cruising around town or out for the long haul, your bike should welcome you like an old friend and feel like an extension of yourself. So, once you've picked the bike, it's time to choose the suspension that best equips your ride to your personal dimensions.



A STRONG FOUNDATION



Being sure-footed at a stop or when parking your bike enhances your feelings of control and confidence. Adjusting the ride height by lowering the suspension may be the first step in fitting the bike to your inseam length. Combining a low-profile suspension and a narrow seat is the easiest way for a shorter rider to fit comfortably on a larger bike.

THE FIT SHOP LIST



Here are a few options to consider when outfitting your bike to fit you. Find your model and flip to the pages for more information. For more details, visit h-d.com/fitshop.

	2015	SUSPENSION	SEATS	HANDLEBARS	FOOT SUPPORTS
	FLHR FLHRC	Premium Ride Low Front Suspension Premium Ride Low Rear Suspension Profile® Low Rear Suspension	Super Reduced Reach® Seat Reduced Reach Seat Brawler®/Sidekick® Seat Badlander® Seat Low-Profile Bucket Seat Tallboy® Seat Sundowner™ Seat Harley Hammock® Seat Road Zeppelin® Seat	12" & 16" Fat Ape Road King® Fat Bar Reduced Reach Bar Tallboy Bar	Adjustable Highway Pegs Extended Shift Levers Extended Reach Rider Footboards Adjustable Passenger Footboards & Pegs
	FLHTCU FLHTK	Premium Ride Low Front Suspension Premium Ride Low Rear Suspension Profile Low Rear Suspension	Super Reduced Reach Seat Reduced Reach Seat Brawler / Sidekick Seat Badlander Seat Low-Profile Bucket Seat Tallboy Seat Sundowner Seat Harley Hammock Seat Road Zeppelin Seat	Bat Wing Mini-Ape Reduced Reach Bar Tallboy Bar	Adjustable Highway Pegs Extended Shift Levers Extended Reach Rider Footboards Adjustable Passenger Footboards & Pegs
	FLHX FLTRXS	Premium Ride Low Front Suspension	Super Reduced Reach Seat Reduced Reach Seat Brawler / Sidekick Seat Badlander Seat Low-Profile Bucket Seat Tallboy Seat Sundowner Seat Harley Hammock Seat Road Zeppelin Seat	Bat Wing Mini-Ape Reduced Reach Bar Tallboy Bar	Adjustable Highway Pegs Extended Shift Levers Extended Reach Rider Footboards Adjustable Passenger Footboards & Pegs
	FLTRX FLHXS	Premium Ride Low Front Suspension	Super Reduced Reach Seat Reduced Reach Seat Brawler / Sidekick Seat Badlander Seat Low-Profile Bucket Seat Tallboy Seat Sundowner Seat Harley Hammock Seat Road Zeppelin Seat	Road Glide® Bar	Adjustable Highway Pegs Extended Shift Levers Extended Reach Rider Footboards Adjustable Passenger Footboards & Pegs
	FLRT (Freewheeler™)	-	Reduced Reach Seat Sundowner Seat	Tallboy Bar	Adjustable Highway Pegs Extended Shift Levers Extended Reach Rider Footboards
	FLHTCUTG (Tri Glide®)	-	Super Reduced Reach Seat Reduced Reach Seat Tallboy Seat	Bat Wing Mini-Ape Reduced Reach Bar Tallboy Bar	Adjustable Highway Pegs Extended Shift Levers Extended Reach Rider Footboards

TOURING & TRIKE 427

Suspension



A. PREMIUM RIDE SINGLE CARTRIDGE FORK KIT



B. PREMIUM RIDE DOUBLE CARTRIDGE FORK KIT



C. PREMIUM RIDE CARTRIDGE STYLE FRONT END LOWERING KIT (54599-02 SHOWN)



D. PROFILE LOW TOURING FRONT LOWERING KIT (54564-09 SHOWN)



D. PROFILE LOW TOURING FRONT LOWERING KIT (46875-09 SHOWN)



D. PROFILE LOW TOURING FRONT LOWERING KIT (54614-05 SHOWN)

A. PREMIUM RIDE SINGLE CARTRIDGE FORK KIT¹

This Cartridge Fork Kit converts the standard Original Equipment front suspension into a high-performance suspension with superior ride quality. The Cartridge Fork Kit complements the Premium Ride Hand-Adjustable Rear Shocks (Low-Profile and Standard-Height) by providing a balanced suspension system capable of delivering superior ride characteristics. The front fork kit improves resistance to front brake dive, improves cornering and enhances bottoming control. A perfect addition during the installation of chrome or gloss black lower fork sliders, the kit includes fork pipes, cartridges, fork bolts, main springs and oil seals. Available in Standard Ride Height and Low Ride Height versions.

45500158 Standard-Height. **\$349.95**
Fits '14-later Touring models. Does not fit Trike models.

45500157 Low-Profile. **\$349.95**
Fits '14-later Touring models. Does not fit Trike models. Stock on '15-later FLHTKL and FLHTCUL models. Must only be installed on vehicles equipped with lowered rear shocks.

B. PREMIUM RIDE DOUBLE CARTRIDGE FORK KIT¹

This Double Cartridge Fork Kit converts the standard Original Equipment front suspension into a high-performance suspension with superior ride quality. The Double Cartridge Fork Kit complements the Premium Ride Hand-Adjustable Rear Shocks (Low-Profile and Standard-Height) by providing a balanced suspension system capable of delivering superior ride characteristics. The front fork kit improves resistance to front brake dive, improves cornering and enhances bottoming control. A perfect addition during the installation of chrome or gloss black lower fork sliders, the kit includes fork pipes, cartridges, fork bolts, main springs and oil seals.

45500106 **\$429.95**
Fits '09-'13 Touring models. Does not fit Trike models.

C. PREMIUM RIDE CARTRIDGE STYLE FRONT END LOWERING KIT¹

A complete kit designed to lower the front end of your Touring bike by approximately 1.0". A great accessory to add when installing your Chrome or Gloss Black Lower Fork Sliders. Must only be installed on vehicles equipped with Profile Low Touring Shocks P/N 54631-02B.

54599-02 Fits '02-'08 Road King® models. **\$199.95**

54598-02 **\$139.95**
Fits '02-'05 Touring models (except Road King).

D. PROFILE® LOW TOURING FRONT LOWERING KIT^{1,2}

Place the rider's feet firmly on the ground. This kit utilizes components designed to provide a 1.0" decrease in ride height.

54564-09 **\$159.95**

Fits '09-'13 Touring models (except FLHR, FLHRC, FLTRSE3, FLTRXSE/2, FLHRSE5, FLHXSE/2/3, FLHP and FLHPE models). Does not fit Trike models. Must only be installed on vehicles equipped with Profile® Low Touring Shocks P/N 54635-09 or Premium Ride Low Shocks P/N 54680-10. Can be installed on FLHX and FLTRX models with Original Equipment rear shocks.

46875-09 **\$159.95**

Fits '09-'13 Road King models. Must only be installed on vehicles equipped with Profile Low Touring Shocks P/N 54635-09.

54614-05 **\$104.95**

Fits '02-'08 Road King models. Must only be installed on vehicles equipped with Profile Low Touring Shocks P/N 54631-02B.

54628-06 **\$104.95**

Fits '06-'08 Touring models (except Road King or FLH Police models). Must only be installed on vehicles equipped with Profile Low Touring Shocks P/N 54631-02B. Can be installed on FLHX models with Original Equipment rear shocks.



¹**WARNING:** Installation of any accessory suspension components may affect cornering clearance and jiffy stand operation. This could distract the rider, causing loss of control and death or serious injury.



²**WARNING:** The Profile Low Front Spring Kit cannot be used independently and must be used with the appropriate Profile Rear Shock Lowering Kit. Installation of any accessory suspension components may affect cornering clearance and jiffy stand operation. This could distract the rider, causing loss of control and death or serious injury.

Notice: The prices appearing in this catalog are the manufacturer's suggested retail prices. Actual retail prices may vary.

428 TOURING & TRIKE

Suspension

A. PREMIUM RIDE HAND-ADJUSTABLE TOURING SHOCKS*

Experience the ultimate in superior ride quality with these Premium Touring Shocks. These shocks utilize a single tube, nitrogen charged emulsion design. The design offers enhanced compression and rebound damping compared to the Original Equipment-style air adjustable shocks. This provides a controlled yet plush ride with much less bottoming. Larger chambers (40mm diameter pistons and 14mm rods) allow these shocks to react more quickly to impacts. This keeps the tires tracking while minimizing harshness transmitted through the frame. A simple knob behind the left saddlebag allows the rider to conveniently modify the spring preload via a hydraulic adjuster. Available in Standard Ride Height and Low Ride Height versions.

54000091 Low-Profile. **\$549.95**
Fits '09-later Touring models. Does not lower '09-later FLHX, FLTRX, and FLTRSE3 models. Stock on FLHRSE5, FLHXSE/2/3, FLTRXSE/2, FLHXS, FLHXSE, FLHTKL, FLHTCUL, and FLTRXS models. Does not fit Trike models.

54000008 Standard-Height. **\$549.95**
Fits '09-later Touring models (except models equipped with Front Lowering Kits).



A. PREMIUM RIDE HAND-ADJUSTABLE TOURING SHOCKS



A. PREMIUM RIDE HAND-ADJUSTABLE TOURING SHOCKS



***WARNING:** Installation of any accessory suspension components may affect cornering clearance and jiffy stand operation. This could distract the rider, causing loss of control and death or serious injury.

Notice: The prices appearing in this catalog are the manufacturer's suggested retail prices. Actual retail prices may vary.

TOURING & TRIKE 429

Suspension



B. PROFILE LOW TOURING SHOCKS

B. PROFILE® LOW TOURING SHOCKS*

Lower the seat height of your Touring model without compromising the ride. The Profile® Low Touring Shocks have been re-valved for a comfortable ride while lowering the seat height by up to .75". The kit maintains the air adjustability feature of the stock shocks.

54635-09 **\$299.95**

Fits '09-later Touring models. Does not lower '09-later FLHX, FLXS, FLTRX, FLTRXS, FLHTKL, FLHTCUL, FLHRSE5, FLHXSE/2/3, FLTRXSE/2 and FLTRSE3 models. Does not fit Trike models.

54631-02B **\$339.95**

Fits '97-'08 Touring models (except FLHRSE3/4). Does not lower FLHRS or FLHX models.

TOURING SUSPENSION AIR PUMPS

This pump was designed to allow safe and simple adjustment of the front and rear air suspension on Touring motorcycles. Unlike a bicycle pump or a fuel station air hose, the hand-operated pump with controllable "micro bleed" valve allows precise adjustment to air volume, and the "no loss" air connector maintains shock pressure when the fitting is removed. The swivel air hose simplifies valve stem attachment.

C. ANALOG TOURING SUSPENSION AIR PUMP

Aluminum housing is compact, lightweight, and durable, and fits easily into your bag for "on-the-road" adjustments. The high-quality 0-60 psi gauge ensures accurate air pressure.

54630-03A **\$49.95**

For use with Touring air suspension components.

D. DIGITAL TOURING SUSPENSION AIR PUMP

Display units can easily be changed between PSI and KPa. The LCD readout operates on a long-lasting, replaceable lithium coin-type battery (CR2032 3V, P/N 66000107).

54000033 **\$69.95**

For use with Touring air suspension components.



C. ANALOG TOURING SUSPENSION AIR PUMP



D. DIGITAL TOURING SUSPENSION AIR PUMP



***WARNING:** Installation of any accessory suspension components may affect cornering clearance and jiffy stand operation. This could distract the rider, causing loss of control and death or serious injury.

Notice: The prices appearing in this catalog are the manufacturer's suggested retail prices. Actual retail prices may vary.

430 TOURING & TRIKE

Foot Controls

A. EXTENDED REACH RIDER FOOTBOARD PANS

This kit extends the rider footboard forward of the stock location by one inch, providing the tall rider a comfortable riding position. When paired with Extended Reach Brake and Shift Levers, these pans allow riders with large boot sizes ample room to reposition their feet during a long ride. Available in traditional D-shape or Swept Wing design, Extended Reach footboard pans accept Original Equipment or accessory rider footboard inserts. The kit includes left and right footboard pans.

Fits '02-later Touring and Trike models (except FLHTKL and FLHTCUL). Also fits '97-'01 Touring models equipped with Extended Reach Billet Style Brake Lever P/N 42638-03.

50409-04	Traditional Shape.	\$89.95
54145-10	Swept Wing.	\$89.95

B. EXTENDED LENGTH RIDER RUNNING BOARDS

Stretching your legs and moving your feet during a long ride relieves muscle tension and reduces rider fatigue. At 4.0" longer (1.0" in front, 3.0" in back) and .5" wider than the Original Equipment rider footboards, these ergonomically friendly running boards provide plenty of space for riders to reposition their feet for maximum comfort. When used in conjunction with available Extended Brake and Shift Levers, the long legged rider will have even more room to stretch out on long rides. The easy-to-install kit includes left and right footboard pans with vibration-isolated inserts that are styled to complement the Crested Bar & Shield controls collection, or most other chrome and rubber collections.

50500158	Chrome.	\$199.95
-----------------	---------	-----------------

Fits '00-later FL Softail® (except FLS, FLSTFB, FLSTN, FLSTNSE, and FLSTSE/2/3, '08-later Touring (except FLHTKL and FLHTCUL) and '09-'13 Trike models. Not for use with Jiffy Stand Kit P/N 5000000 or Jiffy Stand Extension Kit P/N 50233-00, 50000008 and 50000023.

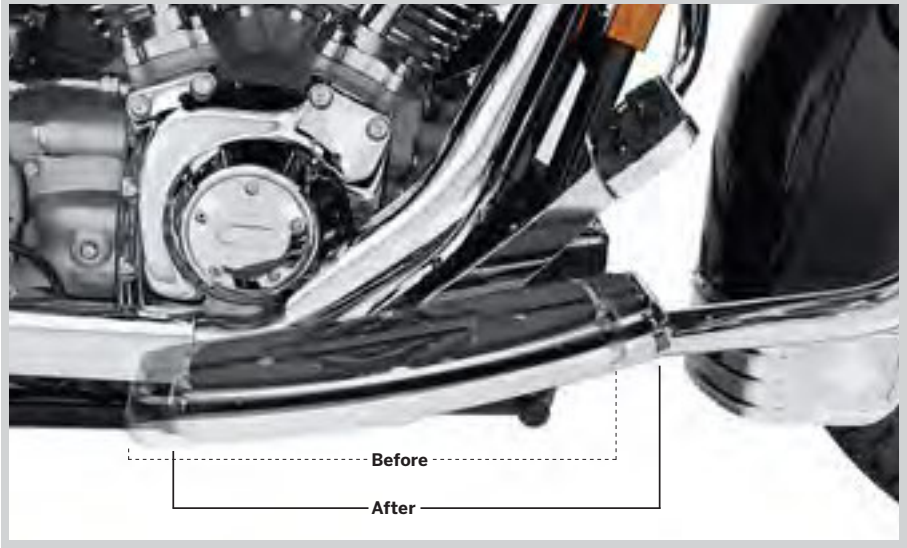

A. EXTENDED REACH RIDER FOOTBOARD PANS – TRADITIONAL SHAPE

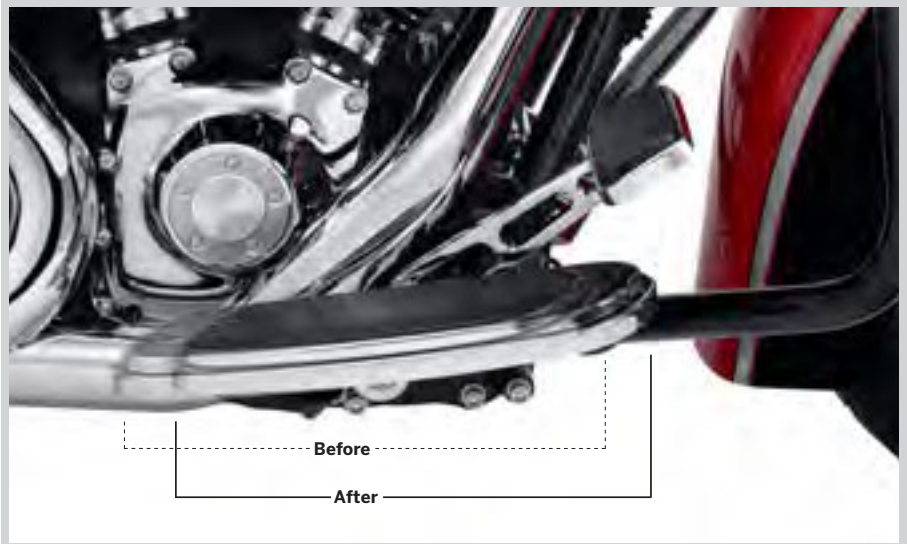

A. EXTENDED REACH RIDER FOOTBOARD PANS – SWEEP WING



B. EXTENDED LENGTH RIDER RUNNING BOARDS

Notice: The prices appearing in this catalog are the manufacturer's suggested retail prices. Actual retail prices may vary.



C. BILLET STYLE BRAKE LEVER – EXTENDED REACH



C. EXTENDED BRAKE LEVER – COMPARISON TO STOCK LENGTH



D. BILLET STYLE HEEL/TOE SHIFT LEVER – EXTENDED REACH

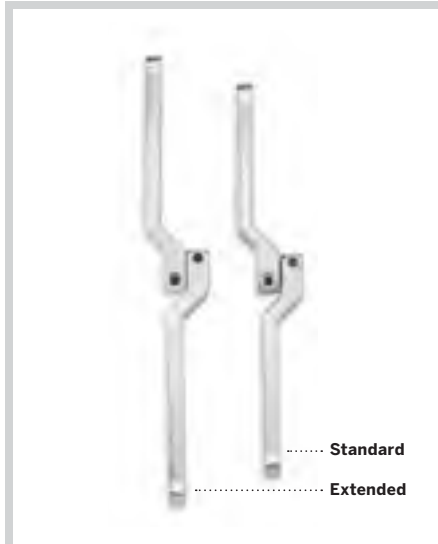

D. EXTENDED HEEL/TOE SHIFT LEVER – COMPARISON TO STOCK



E. JIFFY STAND EXTENSION

C. BILLET STYLE BRAKE LEVER – EXTENDED REACH

Ride tall in the saddle. This billet style Brake Lever features a 1.0" longer arm than the Original Equipment brake lever, allowing tall riders to stretch their legs and straighten their knees for added comfort and control. The additional room also provides riders with large boot sizes ample room to move and reposition their feet on the footboard. Styled to complement our billet style mirror stems, these Billet Style Brake Levers are forged, machined and polished for a beautiful, custom look. When combined with the available Extended Reach Shift Lever, long-limbed riders can straighten their legs and ride in comfort. Brake pedal pads sold separately.

41600012 Chrome. **\$169.95**
Fits '08-'13 Touring models (except FLHTCU, FLHTK, FLTRU and models equipped with fairing lowers).

42638-03 Chrome. **\$169.95**
Fits '97-'07 Touring models.

D. BILLET STYLE HEEL/TOE SHIFT LEVER – EXTENDED REACH

Stretch out in style. Both the heel and toe sections of this Shift Lever are 1.0" longer than traditional levers, separating the distance between the heel/toe shift by 2.0" total. This added space provides a comfortable riding position for a tall rider, and allows a rider with a large boot extra room to move. Styled to complement our billet style mirror stems, these Billet Style Shift Levers are forged, machined and polished for a beautiful, custom look. When combined with the available Extended Reach Brake Lever, long-limbed riders can straighten their legs and ride in comfort. Kit includes a front and rear lever and mounting hardware.

33600001 Chrome. **\$149.95**
Fits '86-later FL Softail®, '88-later Touring and Trike models.

E. JIFFY STAND EXTENSION

Jiffy Stand Extension Kits have been ergonomically designed to simplify the deployment and retraction of the jiffy stand. The extension is shaped to simplify locating the tab with your boot, and aid in swinging the jiffy stand into position. The move feels natural, and adds confidence when parking your motorcycle in a tight spot. Kit mounts to Original Equipment jiffy stand, and includes all required mounting hardware.

50000023 **\$39.95**
Fits '91-later Touring models.

432 TOURING & TRIKE

Foot Controls

A. BILLET STYLE REAR BRAKE LEVER

Styled to complement our billet style mirror stems and shift levers, these Billet Style Rear Brake Levers are forged from billet aluminum, then machined and polished for a beautiful, custom look. Available in your choice of finishes. Lever matches the length of the Original Equipment brake lever. Brake pedal pads sold separately.

Fits '14-later Touring and Trike models.

41600079	Edge Cut.	\$174.95
41600082	Chrome.	\$174.95

Fits '08-'13 Touring and Trike models.

42638-08A	Chrome.	\$169.95
40091-10	Edge Cut.	\$169.95
46883-09	Satin Black.	\$169.95

Fits '97-'07 Touring models.

42638-00A	Chrome.	\$169.95
------------------	---------	-----------------

B. RIDER FOOTBOARD HEEL GUARD

Avoid damaged boots and hours of cleaning melted rubber scuff marks from your exhaust shield. This Heel Guard mounts to the right-side rider footboard and protects your boot from contact with the hot exhaust shield. The subtle curved shape keeps the boot heel away without restricting fore-and-aft movement of the rider's foot. Kit includes chrome guard with cutaway Bar & Shield logo and all mounting hardware.

50500225	\$64.95
-----------------	----------------

Fits '12-later Dyna® FLD, '86-later FL Softail®, '86-later Touring and '09-later Trike models equipped with Traditional and Swept Wing footboards. Does not fit models equipped with Half-Moon, Tapered or Burst footboards, Extended Reach Rider Footboards P/N 50409-04 or 54145-10, Rider Running Boards P/N 50500158 or Screamin' Eagle® Fat Exhaust Shield Kits.



A. BILLET STYLE REAR BRAKE LEVER – CHROME



A. BILLET STYLE REAR BRAKE LEVER – EDGE CUT



A. BILLET STYLE REAR BRAKE LEVER – SATIN BLACK



B. RIDER FOOTBOARD HEEL GUARD



B. RIDER FOOTBOARD HEEL GUARD

Notice: The prices appearing in this catalog are the manufacturer's suggested retail prices. Actual retail prices may vary.

TOURING & TRIKE 433

Foot Controls



C. BILLET STYLE HEEL/TOE SHIFT LEVER – CHROME

C. BILLET STYLE HEEL/TOE SHIFT LEVER

Styled to complement our billet style mirror stems, these Billet Style Shift Levers are forged from 7075-T6 aluminum, then machined and polished for a beautiful, custom look. Available in your choice of mirror-chrome, satin black powder coat, or edge cut black anodized and machined aluminum finishes. Kit includes a front and rear lever and chrome hardware.

Fits '86-later FL Softail®, '88-later Touring and Trike models.

34535-00B	Chrome.	\$149.95
34045-10	Edge Cut.	\$149.95
34023-08	Satin Black.	\$149.95

D. FOLDING HEEL SHIFTER

Give your left foot a little extra room. Folding Heel Shifter permits the rider to move the rear shift peg out of the way when on the open road, while retaining heel/toe shift functionality around town. Positive detent holds the peg in the selected position, and can be adjusted while riding. Easy to install, the replacement rear lever is chrome-plated, and shaped to match the Original Equipment toe shift lever. Lever accepts stock or accessory shifter peg.

33876-07 **\$79.95**

Fits '86-later FL Softail, '88-later Touring and Trike models.

E. HEEL/TOE SHIFTER SHAFT COVER

Conceal the splined end of the shifter shaft when you remove the heel shift lever. The easy-to-install chrome-plated aluminum billet cap is held in place with a flush Allen® screw for a clean look.

35471-05 **\$18.95**

Fits '82-later FL Softail, Touring and Trike models equipped with heel/toe shift levers. Installation requires removal of heel shift lever.

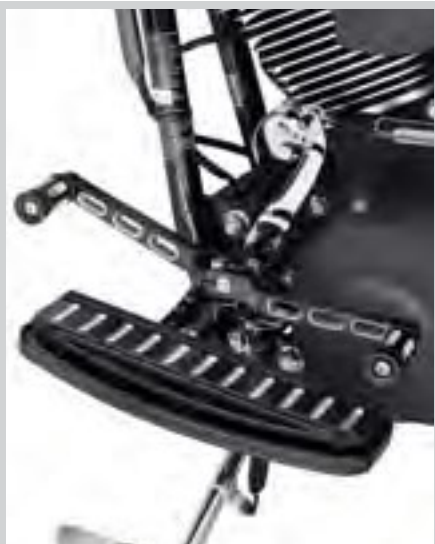

C. BILLET STYLE HEEL/TOE SHIFT LEVER – EDGE CUT



C. BILLET STYLE HEEL/TOE SHIFT LEVER – SATIN BLACK



D. FOLDING HEEL SHIFTER – RETRACTED POSITION



E. HEEL/TOE SHIFTER SHAFT COVER

Notice: The prices appearing in this catalog are the manufacturer's suggested retail prices. Actual retail prices may vary.

434 TOURING & TRIKE

Foot Controls

A. CUSTOM GEAR SHIFT LINKAGES

Kick your custom into gear with this collection of high-quality Custom Shift Linkages. Available in a variety of designs to match your bike's style, these aluminum linkages feature aircraft-quality rod ends for easy adjustment and smooth operation. The easy-to-install linkage kit includes a transmission lever cover and decorative acorn nuts and bolts for a complete custom look.

Fits '86-later Softail®, Touring and Trike models. (Does not fit '97-'99 FLSTS models or models equipped with Softail Extended Reach Forward Controls.)

1. 33900134	Silencer Brushed Nickel.	\$129.95
2. 33857-09	FLHX Black Anodized.	\$129.95
3. 33915-09	Diamond Black.	\$129.95
4. 34018-08	Slotted – Black Anodized.	\$129.95
5. 34850-09	Skull.	\$129.95
6. 33851-09	Road King® Scripted.	\$129.95
7. 33840-09	Flame.	\$149.95
8. 33801-09	Harley-Davidson Scripted.	\$129.95
9. 33762-09	Ball-Milled with Bar & Shield Logo.	\$129.95
10. 33760-09	Slotted with Bar & Shield Logo.	\$129.95
11. 33884-09	Smooth with Bar & Shield Logo.	\$109.95
12. 33823-09	Tribal.	\$149.95
13. 33814-98A	Round.	\$89.95

B. GEAR SHIFT LINKAGE COVERS

A simple and inexpensive way to detail your Touring bike. These easy-to-install chrome-plated covers conceal the stock gear shifter linkage for a brilliant finish. Kit includes all necessary mounting hardware.

Fits '99-later Touring and Trike models with stock gear shift linkage.

1. 46301-01	Diamond.	\$47.95
2. 46303-01	"Harley-Davidson" Script.	\$42.95
3. 46305-01	Engraved "Harley-Davidson".	\$42.95



A. CUSTOM GEAR SHIFT LINKAGES



B. GEAR SHIFT LINKAGE COVERS

Notice: The prices appearing in this catalog are the manufacturer's suggested retail prices. Actual retail prices may vary.

TOURING & TRIKE 435

Foot Controls



C. REAR MASTER CYLINDER COVER – CHROME (46463-08 SHOWN)



C. REAR MASTER CYLINDER COVER – CHROME



D. REAR MASTER CYLINDER KIT – CHROME



E. JIFFY STAND BRACKET COVER – CHROME



F. BLACK RIDER FOOTBOARD PANS – TRADITIONAL SHAPE



F. BLACK RIDER FOOTBOARD PANS – SWEEP WING SHAPE



G. STREAMLINER RIDER FOOTBOARD KIT



H. STREAMLINER PASSENGER FOOTBOARD AND MOUNT KIT

C. REAR MASTER CYLINDER COVER – CHROME

An easy way to add chrome to your bike is with this chrome-plated version of the stock master cylinder cover.

46463-08 **\$59.95**
Fits '08-later Touring models.

46425-05A **\$39.95**
Fits '06-later Dyna® non-ABS models, Softail® and '05-'07 Touring models.

45149-99C **\$39.95**
Fit '00-'05 Softail and '99-'04 Touring models.

D. REAR MASTER CYLINDER KIT – CHROME

Dress your foot controls in brilliant chrome. This kit replaces the black painted rear master cylinder with a polished and plated version, manufactured from Original Equipment components for proper fit and function. The kit includes the mirror-finish master cylinder body, matching chrome master cylinder cover and polished cover hardware.

41777-05A **\$169.95**
Fits '06-later Softail and '05-'07 Touring models.

41775-04B **\$169.95**
Fits '00-'05 Softail and '99-'04 Touring models.

E. JIFFY STAND BRACKET COVER – CHROME

Chrome-plated cover conceals the black jiffy stand bracket for a cleaner appearance. Works with fairing lowers. No hardware required.

50251-01 **\$41.95**
Fits '96-'07 Touring models.

F. BLACK RIDER FOOTBOARD PANS

Complete the blacked-out transformation. Replace the Original Equipment chrome footboard pans with sinister gloss black. Kit includes both the right and left pan, and is installed using the Original Equipment hardware and insert pad. Custom footboard inserts are sold separately.

Fits '12-later Dyna FLD, '86-later FL Softail (except FLS and FLSTFB), Touring and Trike models (except FLHTKL and FLHTCUL).

51322-08 **\$89.95**
Traditional Shape.

51060-08 **\$89.95**
Swept Wing Shape.

G. STREAMLINER RIDER FOOTBOARD KIT

Add the sleek sweeping footboard design from the Street Glide® to your Touring bike. Kit includes vibration-isolation footboard pads with three chrome bands, and the complete chrome-plated pans that easily bolt in place of the Original Equipment footboards.

50631-04 **\$229.95**
Fits '12-later Dyna FLD, '86-later FL Softail (except FLS and FLSTFB), Touring and Trike models (except FLHTKL and FLHTCUL).

H. STREAMLINER PASSENGER FOOTBOARD AND MOUNT KIT

Styled to match the rider footboards on the Road King® Custom, Road Glide® Custom and Street Glide® models, these Swept Wing Passenger Footboards feature a Streamliner-style rubber pad surrounded by a chrome accent. The smooth Swept Wing footboard pan is chrome-plated throughout to add a custom touch, even in the folded position. Designed for convenient bolt-on installation, the complete kit includes chrome-plated aluminum footboards, rubber pads, mounting hardware and passenger footboard supports.

50378-07B **\$389.95**
Fits '93-later Touring models.

Notice: The prices appearing in this catalog are the manufacturer's suggested retail prices. Actual retail prices may vary.

436 TOURING & TRIKE

Passenger Footboards

A. ADJUSTABLE PASSENGER FOOTBOARD MOUNT KIT

Maximize your passenger's riding comfort. These chrome 5-position adjustable mounts raise and lower the passenger footboard. The lowest position is 2.0" forward from stock, and the highest position is 2.5" higher than stock. Easy to adjust with a common hex wrench. Kit includes left and right adjustable support assembly and all required mounting hardware. Footboard pans and inserts sold separately.

50768-07 **\$379.95**
Fits '93-later Touring models. Does not fit Trike models.



A. ADJUSTABLE PASSENGER FOOTBOARD MOUNT KIT

B. PASSENGER FOOTBOARD AND MOUNT KIT

Convenient bolt-on installation. Includes specially designed mounting stud/brackets for proper installation. Footboards fold up when not in use. Kit includes Original Equipment-style aluminum footboards, rubber pads, mounting hardware and passenger footboard supports.

50379-07B **\$144.95**
Fits '93-later Touring and Trike models.



A. ADJUSTABLE PASSENGER FOOTBOARD MOUNT KIT



B. PASSENGER FOOTBOARD AND MOUNT KIT

C. PASSENGER FOOTBOARD SUPPORTS – BLACK

Add the comfort and convenience of passenger footboards to your Touring motorcycle. These supports are designed to allow installation of traditional D-shaped, Swept Wing, Tapered or Old-Style Passenger Footboards (sold separately) on Touring models. Kit includes left and right supports and installation hardware. Add your choice of passenger footboard pan design and footboard insert to complete your custom look.

50500042 **\$104.95**
Fits '93-later Touring and Trike models.

D. PASSENGER FOOTBOARD SUPPORTS – CHROME

Polished and plated to a mirror finish, this chrome version of the Original Equipment black passenger footboard support adds a custom touch and complements accessory floorboard inserts and covers. Kit includes left and right support, and reuses stock hardware for installation.

53070-00A **\$139.95**
Fits '93-later Touring and Trike models.



C. PASSENGER FOOTBOARD SUPPORTS – BLACK



D. PASSENGER FOOTBOARD SUPPORTS – CHROME

E. REDUCED REACH PASSENGER FOOTBOARD MOUNT KIT

Kit raises the height of your passenger footboards by approximately 2.25" for increased passenger comfort. Especially desirable on '97-later Touring models due to the frame and saddlebag guard change. Includes mounting hardware.

50789-99B **\$129.95**
Fits '93-later Touring models. Does not fit Trike models. Does not fit with saddlebag guard bags.

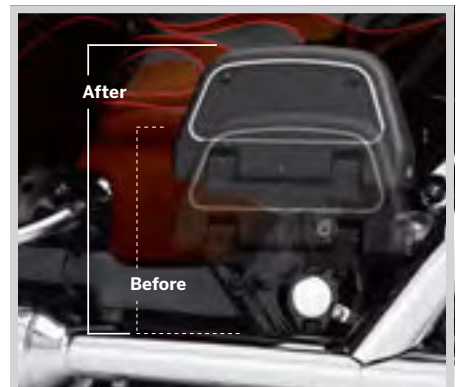

E. REDUCED REACH PASSENGER FOOTBOARD MOUNT KIT

Notice: The prices appearing in this catalog are the manufacturer's suggested retail prices. Actual retail prices may vary.

TOURING & TRIKE 437

Passenger Footboards



F. ADJUSTABLE AUXILIARY PASSENGER FOOTPEG MOUNTS

F. ADJUSTABLE AUXILIARY PASSENGER FOOTPEG MOUNTS

These 3-position adjustable passenger footpeg mounts will keep your companion happy over the long haul. Push-button adjustment lets the passenger reposition their feet to keep blood flowing in all the lower extremities. When combined with the standard footboard, both short and long-limbed passengers should be able to find a comfortable riding position. Pegs can also be pivoted fully rearward to allow the rider the room to get his or her feet on the ground when walking the bike in and out of parking spaces. Kit includes beautifully chromed left- and right-side adjustable mounts and all installation hardware. Complete the custom look with your choice of footpegs (sold separately).

54157-10 **\$239.95**

Fits '10-later Touring models with Original Equipment passenger footboards (except CVO™ models or models equipped with Adjustable Passenger Footboard Mount Kit P/N 50768-07). Also fits '93-later Touring models equipped with Passenger Footboard Kit P/N 50378-07B, 50379-07B or 53070-00A. Does not fit Trike models or models equipped with sidecars. Will not fit with Footpeg P/N 49117-77TB, 49110-98, 91821-85, 50643-82, 50647-82, 49500-92T, 49234-98, 50978-99, 50976-99, 50911-08, 50113-10, 50695-08, 49128-82, 50056-10, 50039-10, 49312-10, 50451-09 and 50178-09.



F. ADJUSTABLE AUXILIARY PASSENGER FOOTPEG MOUNTS

G. ADJUSTABLE PASSENGER FOOTPEG MOUNT KIT

Maximize your passenger's riding comfort. Proper foot position reduces the cramped or stretched-out feeling, and relieves pressure on the knees and the tailbone. These adjustable mounts raise and lower the passenger footpeg to accommodate taller and shorter passengers. Easy to adjust with common tools, the mount adjusts through a 360° range (depending on model), allowing both fore and aft and up and down height adjustment. Kit includes left and right adjustable support assembly and all required mounting hardware. Footpegs sold separately.

50763-09 **\$149.95**

Fits models with H-D® male mount-style passenger footpeg supports (except Softail® models). Does not fit with Heel Raiser Footpeg Kit P/N 50178-09. Does not fit the rider position.

H. PASSENGER FOOTPEG MOUNT KIT – CHROME

Designed specifically for the sport-touring rider, this chrome-plated kit allows passenger footboards to be removed and replaced with a variety of male mount-style Harley-Davidson® footpegs. The kit has 3 adjustable height positions and includes all hardware.

50198-97B **\$129.95**

Fits '93-later Touring models. Does not fit Trike models.



G. ADJUSTABLE PASSENGER FOOTPEG MOUNT KIT

H. PASSENGER FOOTPEG MOUNT KIT – CHROME

Notice: The prices appearing in this catalog are the manufacturer's suggested retail prices. Actual retail prices may vary.

438 TOURING & TRIKE

Passenger Footboards

A. PASSENGER FOOTBOARD PANS – CHROME

Replace the factory black painted passenger footboard with the custom look of smooth chrome. The kit includes left- and right-hand traditional D-shaped footboard pans, chrome-plated, and ready to install with your Original Equipment hardware. Footboard inserts and footboard supports sold separately.

50752-04 **\$169.95**

Fits '86-later Touring and Trike, '00-later Softail® and '06-later Dyna® models equipped with passenger footboard supports.

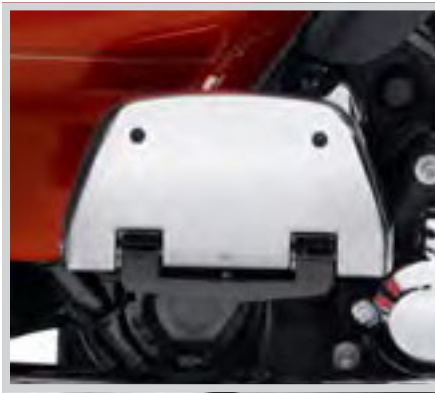

A. PASSENGER FOOTBOARD PANS – CHROME

B. SWEEP WING PASSENGER FOOTBOARD PANS

These unique Swept Wing Passenger Footboard pans complement the Swept Wing Rider Footboard shape, and allow you to replace the Original Equipment passenger footpegs on certain models with footboards. When folded, the footboard displays a mirror-chrome surface in your choice of smooth or "ball-milled" grooved design. Footboard inserts and footboard supports sold separately.

Fits '86-later Touring, '00-later Softail and '06-later Dyna models equipped with passenger footboard supports. Does not fit Trike models.

50716-04 Chrome – Smooth. **\$159.95**

50357-04 Chrome – Grooved. **\$169.95**

50500041 Black – FLHX Script. **\$169.95**



B. SWEEP WING PASSENGER FOOTBOARD PANS – CHROME SMOOTH

C. HALF-MOON PASSENGER FOOTBOARD PANS AND INSERTS

Styled to match the Half-Moon Rider Footboards, these classic passenger footboards add both style and comfort to your nostalgic ride. Available in mirror-finish chrome or gloss black finish, the kit includes left and right footboard pan and vibration-isolation footboard inserts. Model-specific footboard mounts are sold separately.

Fits '86-later Touring, '00-later Softail and '06-later Dyna models equipped with passenger footboard supports. Does not fit Trike models.

50807-08 Chrome. **\$189.95**

50810-08 Gloss Black. **\$179.95**



B. SWEEP WING PASSENGER FOOTBOARD PANS – CHROME GROOVED

B. SWEEP WING PASSENGER FOOTBOARD PANS – BLACK FLHX SCRIPT



C. HALF-MOON PASSENGER FOOTBOARD PANS – CHROME

C. HALF-MOON PASSENGER FOOTBOARD PANS – GLOSS BLACK

Notice: The prices appearing in this catalog are the manufacturer's suggested retail prices. Actual retail prices may vary.

TOURING & TRIKE 439

Passenger Footboards



D. ROAD KING CLASSIC PASSENGER FOOTBOARD COVERS



D. ROAD KING® CLASSIC PASSENGER FOOTBOARD COVERS

The latest in the family of Road King® Classic-inspired accessories, this chrome-plated steel footboard cover features a chrome die-cast Road King Classic medallion with black accents and a stylish leather accent piece. Mounting hardware included.

50246-00 **\$79.95**

Fits '87-later Touring and Trike, '86-later FL Softail® and '06-later Dyna® models equipped with traditional D-shaped aluminum passenger footboards.

E. V-LOGO PASSENGER FOOTBOARD COVERS

V-Logos are die-cast aluminum integrated with the cover, then chrome-plated for a desirable shine. Includes all mounting hardware.

50194-96 **\$65.95**

Fits '87-later Touring and Trike, '86-later FL Softail and '06-later Dyna models equipped with traditional D-shaped aluminum passenger footboards.



E. V-LOGO PASSENGER FOOTBOARD COVERS



F. CONCHO PASSENGER FOOTBOARD COVERS

F. CONCHO PASSENGER FOOTBOARD COVERS

Heritage Softail® Classic-inspired conchos make these covers look great whether footboards are up or down.

50193-96 **\$79.95**

Fits '87-later Touring and Trike, '86-later FL Softail and '06-later Dyna models equipped with traditional D-shaped aluminum passenger footboards.

G. WILLIE G SKULL PASSENGER FOOTBOARD COVERS

Chrome-plated steel footboard cover disguises the Original Equipment passenger footboard, and features a three-dimensional sculptured medallion with the Harley-Davidson skull logo. This easy-to-install kit includes all required mounting hardware.

50836-07 **\$79.95**

Fits '87-later Touring and Trike, '86-later FL Softail and '06-later Dyna models equipped with traditional D-shaped aluminum passenger footboards.



G. WILLIE G SKULL PASSENGER FOOTBOARD COVERS



H. HARLEY-DAVIDSON SCRIPT PASSENGER FOOTBOARD COVERS

H. HARLEY-DAVIDSON SCRIPT PASSENGER FOOTBOARD COVERS

Easy installation using chrome hardware.

50782-91 **\$65.95**

Fits '87-later Touring and Trike, '86-later FL Softail and '06-later Dyna models equipped with traditional D-shaped aluminum passenger footboards.

I. ELECTRA GLO™ LIGHTED PASSENGER FOOTBOARD COVER KIT

This innovative LED light kit covers the bottom side of the passenger footboard. When the passenger footboard is folded in the up position, the light will shine to the side and act as an auxiliary side marker light. When the board is folded down, the light illuminates the ground with a pool of soft light. Kit includes a pair of LED lamps with red lenses, chrome covers with Bar & Shield logo, chrome hardware, and all necessary installation components.

NOTE: Some local regulations prohibit using colored lights during vehicle operation on public streets. May not conform to local lighting regulations.

50541-03A **\$179.95**

Fits '84-later Softail, Touring and Trike models equipped with traditional D-shaped passenger footboards. '14-later Touring and Trike models require separate purchase of Wiring Harness P/N 69200722.



I. ELECTRA GLO LIGHTED PASSENGER FOOTBOARD COVER KIT

TOURING

Notice: The prices appearing in this catalog are the manufacturer's suggested retail prices. Actual retail prices may vary.

440 TOURING & TRIKE

Engine Guards

A. MUSTACHE ENGINE GUARD*

Combine classic shape and modern function for a unique twist on engine protection. The flow of this engine guard complements the bike's traditional style while the gracefully curved upper section incorporates highway pegs into the shape. The integrated rubber pads offer a comfortable and slip-resistant cushion for your feet while traveling the open road. One-piece engine guard kit includes all required mounting hardware.

Fits '09-later Touring models (except Road Glide®). Does not fit models equipped with fairing lowers.

49155-09A Chrome. **\$269.95**

49442-10 Gloss Black. **\$269.95**

Fits '97-'08 Touring models (except Road Glide). Does not fit models equipped with fairing lowers.

49155-05B Chrome. **\$269.95**

B. ENGINE GUARD – GLOSS BLACK*

Protect your bike without sacrificing ground clearance or style. The one-piece engine guard is designed to complement the lines of the motorcycle, and the black finish adds the perfect finishing touch. Before the tough black powder coat finish is applied, these engine guards get an extra layer of protection from an E-Coat dip. So go on and install Engine Guard Mount Footpegs because this finish will go the distance.

49050-09A **\$214.95**

Fits '09-later Touring and Trike models. FLHXXX and FLRT models require the separate purchase of Steering Damper Bracket P/N 83865-09.

46549-03 Fits '97-'08 Touring models. **\$214.95**



A. MUSTACHE ENGINE GUARD – CHROME



A. MUSTACHE ENGINE GUARD – GLOSS BLACK



B. ENGINE GUARD – GLOSS BLACK



***WARNING:** Engine guards may provide limited leg and cosmetic vehicle protection under unique circumstances (fall over while stopped, very low speed slide). They are not made nor intended to provide protection from bodily injury in a collision with another vehicle or any other object.



***WARNING:** Do not use engine guard footpegs under normal stop and go operating conditions. Doing so could result in death or serious injury.



***WARNING:** Do not use highway pegs under normal stop and go operating conditions. Doing so could result in death or serious injury.

Notice: The prices appearing in this catalog are the manufacturer's suggested retail prices. Actual retail prices may vary.

TOURING & TRIKE 441

Engine Guards



C. ENGINE GUARD – CHROME

C. ENGINE GUARD – CHROME*

Protect your bike without sacrificing ground clearance or style. The one-piece engine guard is designed to complement the lines of the motorcycle, and the bright chrome finish adds the perfect finishing touch.

49050-09A **\$214.95**

Fits '09-later Touring and Trike models. FLHXXX and FLRT models require the separate purchase of Steering Damper Bracket P/N 83865-09.

D. CENTER STAND

Lifting your bike upright and off the side stand is ideal for cleaning and servicing, and reduces the space required for parking – handy where space is at a premium in a crowded garage, a small parking spot, or at a ride-in bike show. The robust chrome Center Stand attaches directly to the frame and does not reduce the lean angle. Designed to work with all Original Equipment suspension configurations and with Profile® suspension lowering kits, the adjustable feet can be set to lift the rear tire clear of the pavement, or to keep the rear tire on the ground for reduced lifting effort. The lifting lever is inconspicuously tucked away, and fits with all Harley-Davidson® Original Equipment and accessory footboards. Kit includes chrome stand, black mounting brackets, and all necessary installation hardware.

91573-09A **\$334.95**

Fits '09-later Touring models (except FLHTCUSE2/3/4/5/6, FLHTKSE, FLTRUSE and models equipped with Adjustable Passenger Footboard Mount Kit P/N 50768-07) with Original Equipment or Profile Low Suspension.

91573-06 **\$339.95**

Fits '99-'08 Touring models with Original Equipment or Profile Low Suspension.

E. DISPLAY STAND

This chrome Display Stand is perfect for ride-in shows. This brilliant polished chrome stand also makes it easier to check transmission fluid levels.

99002-97A **\$269.95**

Fits '97-'08 Touring models. Does not fit FLHRSE3/4, FLHTCUSE2/3 or '07-'08 Police models. Does not fit with oil coolers.



D. CENTER STAND



D. CENTER STAND



E. DISPLAY STAND



***WARNING:** Engine guards may provide limited leg and cosmetic vehicle protection under unique circumstances (fall over while stopped, very low speed slide). They are not made nor intended to provide protection from bodily injury in a collision with another vehicle or any other object.

Notice: The prices appearing in this catalog are the manufacturer's suggested retail prices. Actual retail prices may vary.

442 TOURING & TRIKE

Chassis Trim – Front End

A. LOWER FORK SLIDERS – CHROME

Competitively-priced, these chrome-plated Lower Fork Sliders give your bike upfront style. To ensure proper fitment and function, these sliders are manufactured from Original Equipment components. A perfect addition during the installation of Premium Ride or Profile® Low Front suspension components, the kit features polished, triple chrome-plating and stamped "Harley-Davidson" logo.

45500171 **\$449.95**

Fits '14-later Touring models.

45500200 **\$449.95**

Fits '14-later Trike models.

45500167 **\$449.95**

Fits '00-'13 Touring models.

45315-98 **\$449.95**

Fits '84-'99 Touring models.

83819-09 **\$449.95**

Fits '09-'13 Trike models.

B. LOWER FORK SLIDERS – GLOSS BLACK

These gloss black coated sliders are the ultimate extension of your bike's "dark side" and make a perfect custom addition to your blacked-out ride. Manufactured to Original Equipment specifications, the durable black coating is a great match to other H-D® black components. A perfect addition during the installation of Premium Ride or Profile Low front suspension components, this kit includes right and left sliders.

45500172 **\$449.95**

Fits '14-later Touring models.

46546-03 **\$429.95**

Fits '00-'13 Touring models.



A. LOWER FORK SLIDERS – CHROME



B. LOWER FORK SLIDERS – GLOSS BLACK

Notice: The prices appearing in this catalog are the manufacturer's suggested retail prices. Actual retail prices may vary.

TOURING & TRIKE 443

Chassis Trim – Front End



C. FRONT END KIT – CHROME
(**'14-LATER MODELS**)



C. FRONT END KIT – CHROME
(**'08-'13 MODELS**)



D. FRONT END KIT – GLOSS BLACK
(**'14-LATER MODELS**)



D. FRONT END KIT – GLOSS BLACK
(**'08-'13 MODELS**)

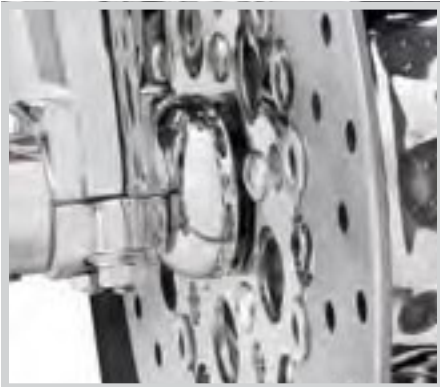

E. FRONT WHEEL SPACERS – CHROME, DOMED



E. FRONT WHEEL SPACERS – CHROME, DOMED



E. FRONT WHEEL SPACERS –
CHROME, TAPERED



E. FRONT WHEEL SPACERS –
CHROME, STRAIGHT

C. FRONT END KIT – CHROME

The front forks on a Harley-Davidson® motorcycle set the tone for the bike, and can lead the way to a full-bore custom statement. So start customizing by adding chrome where it will have the most noticeable impact on the overall look of the bike: your front end. A perfect addition during the installation of Premium Ride or Profile® Low Front suspension components. This package includes components necessary to completely chrome the front forks and includes Chrome Fork Sliders, Chrome Upper Fork Slider Covers, and Classic Chrome Front Axle Nut Covers (kit components vary depending on model).

45800037 **\$569.95**
Fits '14-later Touring models.

45800035 **\$569.95**
Fits '08-'13 Touring models (except models with ABS option).

45800034 **\$569.95**
Fits '08-'13 Touring models with ABS option.

45800036 **\$569.95**
Fits '00-'07 Touring models.

D. FRONT END KIT – GLOSS BLACK

Lead the way to the dark side. This complete blacked-out Front End Kit includes all the major components required to convert the Original Equipment satin-finished front end to a dark custom style. A perfect addition during the installation of Premium Ride or Profile Low Front suspension components. This package includes Gloss Black Fork Sliders, Gloss Black Upper Fork Slider Covers, Gloss Black Front Axle Nut Cover Kit, and Gloss Black Outer Fairing Skirt.

45800038A **\$599.95**
Fits '14-later Electra Glide® and Street Glide® models.

45800022 **\$589.95**
Fits '08-'13 Electra Glide and Street Glide models.

E. FRONT WHEEL SPACERS – CHROME

Complete your total front end with these highly polished chrome-plated wheel spacers. Manufactured to the Original Equipment tolerances, they deliver exact fitment and custom shine.

41371-08 **\$49.95**
Domed.
Fits '08-later Touring models with ABS brakes.

41458-08 **\$49.95**
Tapered.
Fits '08-later Touring models (except models with ABS brakes). Does not fit with Fork Slider End Cover P/N 46282-07.

41610-02 **\$49.95**
Straight.
Fits '00-'07 Touring models.

444 TOURING & TRIKE

Chassis Trim – Front End

A. UPPER FORK SLIDER COVERS – CHROME

Brilliant chrome accents for the upper fork legs. Perfect for finishing off that chromed front end look. When used with H-D® Genuine Motor Accessory Chrome Lower Fork Sliders, you've got a front end that's completely chromed and an appearance that's utterly impressive.

45600022 **\$94.95**

Fits '14-later Touring and Trike models.

45963-97 **\$79.95**

Fits '49-'84 FL, '80-'13 Touring and Trike, '86-later FLS, FLST, FLSTC, FLSTF (except '07), FLSTFB and FLSTN models. Stock on FLSTNSE and FLSTSE.



A. UPPER FORK SLIDER COVERS – CHROME

B. UPPER FORK SLIDER COVERS – GLOSS BLACK

The classic Harley-Davidson® motorcycle color is black. It shows your attitude, your feelings and your desire to be different from the rest. These gloss black accessories are the ultimate extension of the Harley-Davidson philosophy. Manufactured from Original Equipment components, these parts provide superior fit and finish.

45600023 **\$94.95**

Fits '14-later Touring and Trike models.

45591-02 **\$79.95**

Fits '49-'84 FL, '80-'13 Touring, '86-later FLS, FLST, FLSTC, FLSTF (except '07), FLSTFB, FLSTSE/2/3, FLSTNSE and FLSTN models.



B. UPPER FORK SLIDER COVERS – GLOSS BLACK

C. UPPER FORK SLIDER COVERS – CAST CHROME

Add a true custom look to the front forks on your Touring ride. These one-piece cast and chrome plated upper fork covers complement both traditional and contemporary customizing styles and look great with satin finish, chrome or gloss black fork sliders.

45600032 **\$189.95**

Fits '14-later Touring and Trike models.

D. EDGE CUT UPPER FORK SLIDER COVERS

Add an edgy look to your front forks. These billet aluminum one-piece covers are finished in rich black and machined to expose the raw aluminum. The resulting contrasting surfaces complement both traditional and contemporary customizing styles, and look great with the Original Equipment satin-finished front end or with accessory chrome or black sliders. For a complete look, pair these covers with available edge cut wheels, controls, grips, mirrors and saddlebag latches.

45600031 **\$199.95**

Fits '14-later Touring and Trike models.

45600006 **\$189.95**

Fits '80-'13 Touring and Trike models.



C. UPPER FORK SLIDER COVERS – CAST CHROME



D. EDGE CUT UPPER FORK SLIDER COVERS

Notice: The prices appearing in this catalog are the manufacturer's suggested retail prices. Actual retail prices may vary.

TOURING & TRIKE 445

Chassis Trim – Front End



E. BAR & SHIELD LOGO UPPER FORK SLIDER COVERS



E. BAR & SHIELD LOGO UPPER FORK SLIDER COVERS

Add a personal "Harley-Davidson" touch to your chrome front end conversion with these Upper Fork Slider Covers. The chrome-plated covers feature a recessed, engraved Bar & Shield emblem and a beaded contour at the base of the cover. Kit replaces Original Equipment satin fork slider covers for a complete finished look.

46116-03 **\$94.95**
Fits '49-'84 FL and '80-'13 Touring and Trike models.

F. FLAMED UPPER FORK SLIDER COVERS

Raised three-dimensional flames leap from the surface of the mirror-finished Upper Fork Slider Covers. The ideal finishing touch to a chrome front fork conversion, these covers replace the Original Equipment uppers for a custom look. Kit includes left and right covers.

46165-03 **\$94.95**
Fits '49-'84 FL and '80-'13 Touring and Trike models.



F. FLAMED UPPER FORK SLIDER COVERS



G. FORK COVER MEDALLIONS – THE BURST COLLECTION

These 5" medallions feature a curved mounting surface that fit perfectly to Upper Fork Slider Covers. Includes a slider cover mounting template. Easy to install. Sold in pairs.

14100434 **\$59.95**
Fits '49-'84 FL, '80-later Touring and Trike, '86-later FLST, FLSTC, FLSTF (except '07), FLSTFB, FLSTSE/2 and FLSTN models.

H. FORK AXLE RETAINER NUT KIT – CHROME

It's the details that count. Complete the chrome transformation by adding this finishing touch to your chrome fork sliders. This Axle Retainer Nut Kit includes the stylish chrome-plated nuts and chrome lockwashers necessary to replace the stock hardware.

45813-03 **\$8.95**
Fits '84-later Touring and Trike, '86-'07 FLST, FLSTC, FLSTF, FLSTN, '91-'07 FXST and FXSTB and '91-'05 FXDWG models.

Also available:

FORK SLIDER DRAIN SCREW KIT – CHROME

It's the details that count. Complete the chrome transformation by adding this finishing touch to your chrome fork sliders. This Fork Slider Drain Screw Kit includes two chrome-plated drain screws and the seals required to replace the stock hardware.

45848-03 **\$3.95**
Fits '87-later Softail® (except Springer™, FXCW, FXCWC, FXSB, FXSBSE and FXSTD), '87-'13 Touring and '93-'05 FXDWG models.



G. FORK COVER MEDALLIONS – THE BURST COLLECTION



H. FORK AXLE RETAINER NUT KIT – CHROME



Notice: The prices appearing in this catalog are the manufacturer's suggested retail prices. Actual retail prices may vary.

446 TOURING & TRIKE

Chassis Trim – Front End

FRONT AXLE NUT COVERS

Cover the front axle in style. Available in your choice of styles, these custom axle nut covers look great with Original Equipment satin-finish fork sliders or as the finishing touch to a complete chrome or blacked-out front end. Easy to install kits include all necessary mounting hardware. Sold in pairs.

A. FRONT AXLE NUT COVERS

Fits '02-'11 VRSC™ (except VRSCF, VRSCR and '12-later VRSCDX), '15-later XG, '08-later XL, '08-later Dyna®, '07-later Softail® (except Springer™, FXCW, FXCWC, FLSTNSE, FXSBSE, FXST-Aus and FXSTD) and '08-later Touring and Trike models.

44117-07A	Chrome – Die-cast.	\$27.95
43000026	Gloss Black – Die-cast.	\$27.95
44116-07A	Chrome – Billet.	\$42.95
43428-09	Gloss Black – Billet.	\$42.95

Fits '00-'07 Touring models and '04-'07 Dyna models (except '04-'05 FXDWG and '07 FXDSE).

43062-04	Chrome – Die-cast.	\$27.95
43061-04	Chrome – Billet.	\$42.95

Fits '88-'07 XL, '91-'03 Dyna FXD, FXDX, FXDXT, FXDL, FXDS-CONV.; '93-'05 FXDWG, '84-'06 Softail (except Springer and FXSTD), '80-'99 Touring models. Also fits '88-'07 FXR and '87-later FLXR/FXRS-SP and FXWG models.

43899-86A	Chrome – Die-cast.	\$27.95
------------------	--------------------	----------------

B. WILLIE G SKULL FRONT AXLE NUT COVERS

43163-08A		\$34.95
------------------	--	----------------

Fits '02-'11 VRSC (except VRSCF, VRSCR and '12-later VRSCDX), '15-later XG, '88-later XL, '91-later Dyna, '84-later Softail (except Springer, FXCW, FXCWC, FXSB, FXSBSE, FXSTD and FLSTNSE) and '99-later Touring and Trike models.

C. ALUMINATOR® FRONT AXLE NUT COVERS

44114-07		\$42.95
-----------------	--	----------------

Fits '02-'11 VRSC (except VRSCF, VRSCR and '12-later VRSCDX), '08-later Dyna, '07-later Softail (except Springer, FXCW, FXCWC, FXSB, FXSBSE, FXST-Aus, FXSTD and FLSTNSE) and '08-later Touring models.

43059-04		\$42.95
-----------------	--	----------------

Fits '00-'07 Touring models and '04-'07 Dyna models (except '04-'05 FXDWG and '07 FXDSE).

43907-94		\$42.95
-----------------	--	----------------

Fits '88-'07 XL, '91-'03 Dyna FXD, FXDX, FXDXT, FXDL, FXDS-CONV.; '93-'05 FXDWG, '84-'06 Softail (except Springer and FXSTD), '80-'99 Touring models. Also fits '88-'07 FXR and '87-later FLXR/FXRS-SP, FXWG models.

D. "H-D MOTOR CO." LOGO FRONT AXLE NUT COVERS

44148-07A		\$29.95
------------------	--	----------------

Fits '02-'11 VRSC (except VRSCF, VRSCR and '12-later VRSCDX), '15-later XG, '08-later XL, '08-later Dyna, '07-later Softail (except Springer, FXCW, FXCWC, FXSB, FXSBSE, FXST-Aus, FXSTD and FLSTNSE) and '08-later Touring and Trike models.

43063-04		\$27.95
-----------------	--	----------------

Fits '00-'07 Touring models and '04-'07 Dyna models (except '04-'05 FXDWG and '07 FXDSE).

43864-96		\$29.95
-----------------	--	----------------

Fits '88-'07 XL, '91-'03 Dyna FXD, FXDX, FXDXT, FXDL, FXDS-CONV.; '93-'05 FXDWG, '84-'06 Softail (except Springer and FXSTD), '80-'99 Touring models. Also fits '88-'07 FXR and '87-later FLXR/FXRS-SP, FXWG models.

E. TAPERED FRONT AXLE NUT COVERS

44109-07		\$27.95
-----------------	--	----------------

Fits '02-'11 VRSC, (except VRSCF, VRSCR and '12-later VRSCDX), '08-later Dyna, '07-later Softail (except Springer, FXCW, FXCWC, FXSB, FXSBSE, FXST-Aus, FXSTD and FLSTNSE) and '08-later Touring models.

43051-01		\$27.95
-----------------	--	----------------

Fits '00-'07 Touring and '04-'07 Dyna models (except '04-'05 FXDWG and '07 FXDSE).



A. FRONT AXLE NUT COVERS – CHROME



A. FRONT AXLE NUT COVERS – GLOSS BLACK



B. WILLIE G SKULL FRONT AXLE NUT COVERS



C. ALUMINATOR FRONT AXLE NUT COVERS



D. "H-D MOTOR CO." LOGO FRONT AXLE NUT COVERS



E. TAPERED FRONT AXLE NUT COVERS

Notice: The prices appearing in this catalog are the manufacturer's suggested retail prices. Actual retail prices may vary.

TOURING & TRIKE 447

Chassis Trim – Front End



F. BURST FRONT AXLE NUT COVERS



G. FORK SLIDER END COVERS

F. BURST FRONT AXLE NUT COVERS

Finish your blacked-out forks in style. Rich black and prismatic machined surfaces provide the contrast, and the race-track ridges and the inner spider design make a powerful visual statement. This easy to install kit includes mounting hardware.

43000031 **\$69.95**

Fits '02-'11 VRSC™ (except VRSCF, VRSCR and '12-later VRSCDX), '15-later XG, '08-later XL, '08-later Dyna®, '07-later Softail® (except Springer™, FXCW, FXCWC, FXSB, FXSBSE, FXSTD and FLSTNSE) and '08-later Touring and Trike models.

G. FORK SLIDER END COVERS

Lead the way with chrome. This Fork Slider End Cover Kit is contoured to complement the shape of the front fork slider. Designed to conceal the front axle and fork slider hardware, the smooth chrome surface complements both Original Equipment satin finish and accessory chrome lower fork sliders. Complete kit includes all necessary installation hardware.

46282-07 **\$84.95**

Fits '00-'13 Touring (except models equipped with ABS brakes). Installation requires removal of Original Equipment or accessory axle nut covers. Does not fit with Tapered Wheel Spacers P/N 4145-08. Does not fit Trike models.

H. AIR WING CALIPER COVER

Surround your calipers in chrome. These mirror-chrome deep-drawn steel covers hide the Original Equipment painted calipers, and feature a sweeping Air Wing design and subtle Bar & Shield logo to enhance the look. Installation does not require brake line removal. Kit includes left- and right-hand covers and all necessary mounting hardware.

44729-09 **\$94.95**

Fits '08-'13 Touring models. Does not fit Trike models.

I. FRONT CALIPER COVER

Chrome-plated caliper covers styled with stepped contours and textured recess for a distinctive look. Split cover design does not require brake line removal. Sold in pairs.

43798-00 **\$79.95**

Fits '00-'07 Touring models. Does not fit with braided brake lines.

J. AIR WING CALIPER AND ROTOR COVER

Add a custom look to the front of your bike. These easy-to-clean mirror-chrome rotor covers surround the brake disc for a stylish appearance, and the matching deep-drawn steel covers hide the Original Equipment painted calipers. The Caliper Covers feature a sweeping Air Wing design and subtle Bar & Shield logo to enhance the look. Installation does not require brake line removal. Kit includes left- and right-hand covers and all necessary mounting hardware.

44013-09A **\$199.95**

Fits '08-'13 Touring models (except '09 FLTRSE3). Does not fit Trike models.

K. CALIPER ROTOR COVER – CHROME

Add clean, chrome style to your front end with this cover, which features high-quality chrome-plating that complements the lines of your bike.

42230-00 **\$214.95**

Fits '00-'07 Touring models. Requires separate purchase of (1) Medallion Kit P/N 42231-00, 42235-00 or 42232-00.



H. AIR WING CALIPER COVER



I. FRONT CALIPER COVER



J. AIR WING CALIPER AND ROTOR COVER



K. CALIPER ROTOR COVER – CHROME

Notice: The prices appearing in this catalog are the manufacturer's suggested retail prices. Actual retail prices may vary.

448 TOURING & TRIKE

Chassis Trim – Brakes

A. BRAKE CALIPER KIT – RED

Dress your bike in the latest high-performance look. Brilliant red calipers make a powerful visual statement, and set your bike apart from the ordinary. Manufactured from Original Equipment components for proven performance, these calipers will add a stylish touch to the stock bike, or add the perfect finish to a complete custom equipped with chrome or blacked-out wheels, rotors, and fork sliders.

41300116 Front – Dual Disc. **\$499.95**
Fits '06-later VRSC™, '08-later Touring and '09-'13 Trike models. Brake pads sold separately.

41300120 Front – Dual Disc. **\$399.95**
Fits '02-'05 VRSC, '00-'03 XL, '00-'07 Dyna® and '00-'07 Touring models with dual disc front brakes. Brake pads sold separately.



A. FRONT BRAKE CALIPER KIT – RED
(41300116 SHOWN)

B. BRAKE CALIPER KIT – CHROME

Add the shine of chrome to your bike with these highly polished Chrome Brake Caliper Kits. Manufactured from Original Equipment components for proven performance, these calipers are a great addition to the stock bike, or add the finishing touch to a complete custom equipped with chrome wheels, rotors, and fork sliders. (Brake pads and pad pins not included.)

42012-06A Front – Dual Disc. **\$899.95**
Fits '06-later VRSC, '08-later Touring and '09-'13 Trike models.

44392-00A Front – Dual Disc. **\$799.95**
Fits '00-'03 XL, '02-'05 VRSC, '00-'07 Dyna, Softail® and Touring models equipped with dual disc front brakes.



A. FRONT BRAKE CALIPER KIT – RED
(41300120 SHOWN)



B. FRONT BRAKE CALIPER KIT – CHROME
(42012-06A SHOWN)



B. FRONT BRAKE CALIPER KIT – CHROME
(44392-00A SHOWN)

Notice: The prices appearing in this catalog are the manufacturer's suggested retail prices. Actual retail prices may vary.

TOURING & TRIKE 449

Chassis Trim – Brakes



C. CALIPER SCREEN INSERT – CHROME



C. CALIPER SCREEN INSERT – CHROME

These chrome-plated Caliper Inserts replace the Original Equipment satin-finish screens featured on Brembo® brake calipers. Easy pop-in installation. Sold individually.

Fits '06-later VRSC™ and '08-later Touring models

42054-05	Front.	\$29.95
42053-05	Rear.	\$29.95

D. BRAKE CALIPER INSERTS

Easy-to-install inserts add a finishing touch to the front and rear brake calipers. Select a style that follows your custom direction. Self-adhesive backing.

Fits '00-later front and rear brake calipers on all models (except Springer™ front, '08-later Touring and Trike, '04-later XL, '15-later XG and '06-later VRSC models).

1. 44477-99	Classic Chrome.	\$16.95
2. 44476-99	"Harley-Davidson" Script.	\$16.95
3. 44474-99	Flames.	\$16.95
4. 44542-03	Deep Dish.	\$16.95



D. BRAKE CALIPER INSERTS



E. BRAKE CALIPER TRIM DISCS

E. BRAKE CALIPER TRIM DISCS

Available in 1.375" and 1.75" diameters to accommodate front and rear calipers on most '99-earlier models, and front calipers on '00-later Springer models. Easy to install.

1. 44095-96	"H-D Motor Co." – 1.375" Diameter.	\$16.95
1. 44093-96	"H-D Motor Co." – 1.75" Diameter.	\$16.95
2. 99661-92T	Gold Live to Ride – 1.375" Diameter.	\$16.95
2. 99663-92T	Gold Live to Ride – 1.75" Diameter.	\$16.95
3. 99679-98	Flames – 1.375" Diameter.	\$11.95

F. BANJO BOLT KIT – CHROME

Replace the Original Equipment zinc finish brake line hardware with brilliant chrome custom banjo bolts.

41843-08 **\$49.95**

Fits '06-later VRSC, '08-later Touring and '09-'13 Trike models.

BANJO BOLT KIT – CHROME

Replace the Original Equipment 12-point zinc finish brake line hardware with brilliant chrome custom tapered banjo bolts.

41844-06 **\$29.95**

Fits '02-'05 VRSCA and VRSCB models and '93-'07 Touring models. Does not fit with Banjo Bolt Cover P/N 32715-98. Kit includes three .375" banjo bolts and six sealing washers.

G. CALIPER HARDWARE KIT – CHROME

Chrome-plated hardware is a great finishing touch to Chrome Brake Calipers. This kit replaces the Original Equipment black 12-point bolts on a single caliper.

44473-02A **\$44.95**

Fits '00-'07 models (except Springer front caliper, '04-later XL, '06-later FX Softail rear calipers and '06-later VRSC models).



F. BANJO BOLT KIT – CHROME



F. BANJO BOLT KIT – 41843-08



F. BANJO BOLT KIT – 41844-06



G. CALIPER HARDWARE KIT – CHROME

Notice: The prices appearing in this catalog are the manufacturer's suggested retail prices. Actual retail prices may vary.

450 TOURING & TRIKE

Chassis Trim – Brakes

A. CUSTOM CALIPER BOLT COVER KIT

Cover your 12-point caliper bolts in chrome. These easy-to-install chrome covers are held firmly in place with a steel spring clip, and are styled to match the Chrome Rocker Box Bolt and Headbolt Covers.

43824-03 Four Large Covers. **\$23.95**

Fits '00-later front and rear 12-point caliper mounting bolts (except Springer™ front calipers, '15-later XG, '08-later Touring and Trike and '06 VRSCR models).

40955-05 Four Large and Two Small Covers. **\$28.95**

Fits '00-later front brake calipers (except Springer, '15-later XG, '04-later XL, '08-later Touring and Trike, '06-later VRSC™ and models equipped with caliper covers). Also fits rear calipers on '06-later Softail® models (except FXCW).

40959-05 Three Large and Two Small Covers. **\$23.95**

Fits '00-later rear brake calipers (except '15-later XG, '04-later XL, '08-later Touring and Trike, '06-later FXST, FXSTB, FXSTS and FLSTSB, '06-later VRSC and models equipped with caliper covers).



A. CUSTOM CALIPER BOLT COVER KIT

B. 1. BRAKE BLEEDER SCREW COVER

This cover adds chrome to the unfinished bleeder valve on all stock H-D® calipers. Package of two.

43834-98 **\$23.95**

Fits '84-later stock calipers (except XR models).

2. BANJO BOLT COVER

Die-cast chrome cover provides a custom look to your stock banjo bolts. Fits banjo bolts on front and rear brake master cylinders and front and rear calipers. Installs in seconds.

32715-98 **\$21.95**

Fits '84-later models with stock master cylinders and calipers. (Does not fit VRSC Rear Master Cylinder, '06-later VRSC calipers, '08-later Touring and Trike or '04-later XL models.)

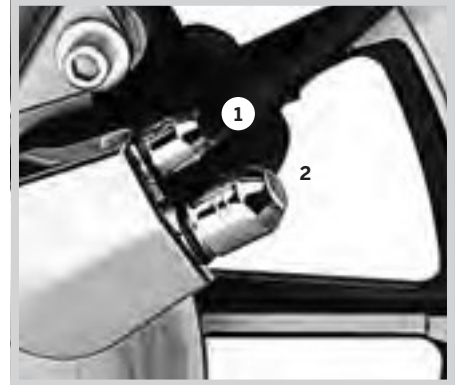

B. BLEEDER SCREW AND BANJO BOLT COVERS

C. BRAKE ROTOR HARDWARE KIT – CHROME

It's the details that make the difference, like this chrome hardware kit that really gets your bike noticed. This hardware adds a unique chrome-plated finish to the Original Equipment or accessory floating brake rotors.

41500095 Button Head – Front **\$39.95**

Fits '09-later Touring models equipped with Enforcer or Impeller Wheels.

91800029 Shoulder Bolts – Front. **\$29.95**

Fits '02-later models equipped with Open Brake Rotor P/N 44343-01, 44553-06A, 41500012A, 41500040 or 41500042.

46646-05 Button Head – Front. **\$13.95**

Fits '90-later models (except VRSC and '14-later Touring and Trike models equipped with Open Brake Rotor P/N 44343-01, 44553-06A, 41500012, 41500040 or 41500042).

46647-05 Button Head – Rear. **\$13.95**

Fits '92-later models.



C. BRAKE ROTOR HARDWARE KIT – CHROME
(41500095 SHOWN)



C. BRAKE ROTOR HARDWARE KIT – CHROME
(91800029 SHOWN)



C. BRAKE ROTOR HARDWARE KIT – CHROME
(46646-05 SHOWN)

Notice: The prices appearing in this catalog are the manufacturer's suggested retail prices. Actual retail prices may vary.

TOURING & TRIKE 451

Fender Trim



D. AIR WING FRONT FENDER RAIL

D. AIR WING FRONT FENDER RAIL*

Shaped by the wind, this aerodynamic front fender rail features an inverted-wing tip and support rails that complement the sweeping lines of the fender. As a stylish replacement for the traditional rubber bumper and rails, the completed installation mirrors the design of the Original Equipment fender tip and spears. The hidden hardware adds to the clean, custom appearance. The mirror-chrome surface and embossed Harley-Davidson lettering finishes the look.

59600022 \$99.95

Fits '14-later FLHTCU, FLHTCUL, FLHTK and FLHTKL models.

59600012 \$99.95

Fits '80-'13 FLHR, FLHRC, FLT, FLHT, FLHTC, FLHTCU, FLHTK, FLHTCUTG and '80-'93 FLHS models. Does not fit '98-later FLHX, FLTR or FLHRS models or any models with a clean front fender.

E. ELECTRA GLIDE® SPORT AND ROAD KING® FRONT BUMPER ASSEMBLY*

Add style and protection to the front fender of your Electra Glide® Sport or Road King® motorcycle.

91085-83D \$139.95

Fits '87-'93 FLHS, '94-'13 FLHR and '96-'13 FLHT models.

Does not fit '98-later FLTR models or Trike models.



D. AIR WING FRONT FENDER RAIL



E. ELECTRA GLIDE SPORT AND ROAD KING FRONT BUMPER ASSEMBLY

F. V-LOGO FRONT FENDER RAIL*

A stylish re-creation of a popular Hydra Glide accessory, this twin tube design sweeps smartly back along the front fender. Matching Touring V-Logo Rear Fender Rail P/N 91100-94 integrates the styling from front to rear. Includes mounting hardware and installation instructions.

91099-94A \$99.95

Fits '80-'13 FLT, FLHT, FLHTC, FLHTCU, FLHTK, FLHR, FLHRC, FLHTCUTG and '80-'93 FLHS models. Does not fit '98-later FLHX, FLTR or FLHRS models.

G. V-LOGO REAR FENDER RAIL*

Designed with a similar styling theme to match our Touring V-Logo Front Fender Rail P/N 91099-94A. Replaces the stock rear fender rail and rubber bumper on Touring models. Chrome-plated twin tubes are crowned with a hand-polished and chrome-plated cast V-Logo reminiscent of the Harley-Davidson® 1953 Golden Anniversary medallion. Includes hardware and installation instructions.

91100-09 \$99.95

Fits '09-later FLHR, FLHRC, FLHT, FLHTC, FLHTCU, FLHTCUL, FLHTK, FLHTKL, FLTR and FLTRU models. Does not fit with mud flaps.

91100-94 \$99.95

Fits '80-'08 FLT, FLHT, FLHR, FLHRC, '98-'03 FLTR and '80-'93 FLHS models. Does not fit with mud flaps.

H. FENDER RAIL INSERTS

This accessory closes the fender rail gap and features a Bar & Shield logo with black grooves for a clean, custom look. Kit includes all necessary hardware and mounting brackets.

91358-99A Front. \$89.95

Fits '80-'13 Tour Glide™, FLHTC, FLHTCU and FLHTCUTG models. Does not fit '98-later FLTR, FLHRS or '94-later FLHR models.

91357-99A Rear. \$74.95

Fits '80-'08 Tour Glide, FLHS, FLHR, FLHT/C and FLHTCU models and '06-'08 FLHX models. Does not fit FLHRCI, FLHRS and FLTR.



F. V-LOGO FRONT FENDER RAIL



G. V-LOGO REAR FENDER RAIL



H. FENDER RAIL INSERT - FRONT



H. FENDER RAIL INSERT - REAR



***WARNING:** Fender rails are decorative items only. Do not strap anything to the rails. Adding any additional weight to the front fender could adversely affect vehicle handling, causing loss of control and death or serious injury.

Notice: The prices appearing in this catalog are the manufacturer's suggested retail prices. Actual retail prices may vary.

452 TOURING & TRIKE

Fender Trim

A. FRONT FENDER TRIM KIT – CHROME

Replace the Original Equipment stainless steel fender trim with a splash of chrome. Kit includes left and right side trim strip.

59209-91T \$29.95

Fits '82-'13 Touring models (except Road Glide® and Road King® Custom), '86-later FLSTN and FLSTC models. Does not fit models equipped with clean front fender.



A. FRONT FENDER TRIM KIT – CHROME

B. FRONT FENDER TRIM

Add a sweeping dash of chrome to the front fender. Chrome-plated tapered spear features a stepped design that accentuates the flowing fender lines. Self-adhesive backing simplifies installation.

14100618 \$44.95

Fits Dyna® FLD, FL Softail®, Touring and Trike models with full front fender.

C. BAR & SHIELD LOGO FRONT FENDER SPEAR

This chrome-plated trim spear adds a sweeping dash of chrome to the front fender. Featuring a raised Bar & Shield logo set against a textured black field, this self-adhesive medallion is easy to install.

91195-04 Large. \$44.95

Fits Dyna FLD, FL Softail, Touring and Trike models (except FLSTSB).

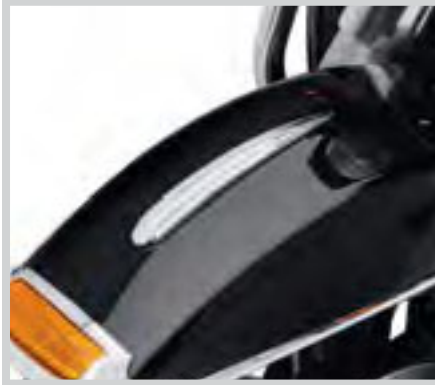

B. FRONT FENDER TRIM KIT



C. BAR & SHIELD LOGO FRONT FENDER SPEAR

D. BAR & SHIELD FENDER TIP LENS KIT

Chrome-plated polycarbonate construction features translucent Bar & Shield emblems. The kit includes front and rear lenses. Front lens features an amber Bar & Shield, rear lens features a red Bar & Shield. Quick and easy installation.

59081-96 Front and Rear. \$29.95

Fits '80-'08 FLHT, FLT, FLHS, FLHR models and '86-'08 FLSTC, '93-'96 FLSTN models. (Does not fit Springer™, FLHRS or FLTR models.)

E. FENDER TIP LENS KIT WITH SKULL LOGO

This chrome-plated Fender Tip Lens Kit adds a little attitude to your ride. The kit features front and rear lenses with a translucent illuminated skull silhouette. The easy-to-install kit includes an amber front lens and red rear lens.

59651-01 \$29.95

Fits '80-'08 Electra Glide®, Tour Glide™, FLHS, Road King (except Road King Classic and FLHRS) and '86-'08 FLSTC and '93-'96 FLSTN models.

F. "LIVE TO RIDE" LOGO FENDER TIP

Made of durable ABS plastic. Includes mounting hardware and installation instructions.

59068-96 Front. \$35.95

Fits '80-'13 FLT, FLHTCUTG, FLHR, FLSTC and '93-'96 FLSTN models (replaces fender lamp assembly). (Does not fit Springer, FLHRS and FLTR models.)

59069-96 Rear. \$35.95

Fits '80-'08 FLT, FLHR, FLSTC and '93-'96 FLSTN models (replaces fender lamp assembly). (Does not fit Springer, FLHRS or FLTR Road Glide models.)



D. BAR & SHIELD FENDER TIP LENS



E. FENDER TIP LENS WITH SKULL LOGO

G. "H-D" CLASSIC FENDER TIP

Stock on Road King Classic models, these nostalgic-look fender tips are also available for other models. Replaces fender lamp assembly.

59002-98 Front. \$31.95

Fits '80-'13 FL, FLHR and FLHTCUTG models and '86-'08 FLSTC models.

59052-98 Rear. \$31.95

Fits '80-'08 FL and FLHR models and '86-'99 FLSTC models. (Does not fit FLSTF and FLTR models.)



F. "LIVE TO RIDE" LOGO FENDER TIP



G. "H-D" CLASSIC FENDER TIP

Notice: The prices appearing in this catalog are the manufacturer's suggested retail prices. Actual retail prices may vary.



H. FRONT FENDER RAIL AND STANCHION KIT

TOURING & TRIKE 453

Fender Trim

H. FRONT FENDER RAIL AND STANCHION KIT*

Chrome-plated accents straight from our 1947 catalog. Includes template for easy installation.

91117-97 **\$69.95**
Fits '84-later FL Softail® (except FLS, FLSTF, FLSTNSE, FLSTFB, FLSTSE/2/3 and FLSTSB) and Touring models.

I. WILLIE G SKULL FENDER SKIRT

This decorative chrome-plated fender skirt is a direct replacement for stock fender skirt. Features a three-dimensional sculptured concho with skull design set off with black accents. Mounting hardware included.

59582-02A **\$59.95**
Fits '80-'13 Touring, '09-'13 Trike, '86-'08 FLSTC, '06 FLST and '93-'96 FLSTN models equipped with Original Equipment fender skirt.

J. FLAMES FENDER SKIRT

Designed as an easy-to-install replacement for the Original Equipment fender skirt, this chrome steel fender skirt features an embossed 3-D flame design. Kit includes mounting hardware.

60179-06 **\$59.95**
Fits '80-'13 Touring, '09-'13 Trike, '86-'08 FLSTC, '06 FLST and '93-'96 FLSTN models equipped with Original Equipment fender skirt.

K. BAR & SHIELD FENDER SKIRT

This rigid-steel fender skirt, designed to replace the original factory-equipped aluminum trim, is formed, polished, and chrome-plated. Its ribbed pattern offers a unique styling element and adds rigidity. Subtle but distinctive brushed aluminum Bar & Shield logos are framed by a stamped-in ribbed outline on both sides.

59228-91 **\$59.95**
Fits '80-'13 Touring, '09-'13 Trike, '86-'08 FLSTC, '06 FLST and '93-'96 FLSTN models equipped with Original Equipment fender skirt.

L. ROAD KING® CLASSIC FENDER SKIRT

The latest in the family of Road King-inspired accessories, this chrome-plated steel fender skirt features four raised accent ribs and a die-cast Road King® Classic medallion in chrome with black accents. Mounting hardware included.

59005-98 **\$59.95**
Fits '80-'13 Touring and '09-'13 Trike models equipped with Original Equipment fender skirt.

M. V-LOGO FENDER SKIRT

V-Logos are die-cast aluminum integrated with the fender skirt, then chrome-plated for a desirable shine. Includes all mounting hardware.

59146-96 **\$59.95**
Fits '80-'13 Touring, '09-'13 Trike, '86-'08 FLSTC, '06 FLST and '93-'96 FLSTN models equipped with Original Equipment fender skirt.

N. CONCHO FENDER SKIRT

This decorative fender skirt features conchos inspired by the Heritage Softail® Classic motorcycle.

59147-96 **\$59.95**
Fits '80-'13 Touring, '09-'13 Trike, '86-'08 FLSTC, '06 FLST and '93-'96 FLSTN models equipped with Original Equipment fender skirt.



I. WILLIE G SKULL FENDER SKIRT



J. FLAMES FENDER SKIRT



K. BAR & SHIELD FENDER SKIRT



L. ROAD KING CLASSIC FENDER SKIRT



M. V-LOGO FENDER SKIRT



N. CONCHO FENDER SKIRT



***WARNING:** Fender rails are decorative items only. Do not strap anything to the rails. Adding any additional weight to the front fender could adversely affect vehicle handling, causing loss of control and death or serious injury.

Notice: The prices appearing in this catalog are the manufacturer's suggested retail prices. Actual retail prices may vary.

454 TOURING & TRIKE

Fender Trim

A. FRONT FENDER ADAPTER KIT

Add a true custom style to your Touring model. This polished and chrome-plated Adapter Kit will allow you to install the smooth curving Fat Boy® or Street Stalker® front fender on your Touring bike. Manufactured from 6061-T6 billet aluminum, this kit includes all necessary mounting hardware. See your Dealer for primed or Color-Matched fender options.

58900085 **\$99.95**
Fits '14-later Touring models (except models equipped with fairing lowers). Does not fit Trike models.

59013-02A **\$84.95**
Fits '00-'13 FLHT, FLHX, FLHTC, FLHTCU and FLHTK models. Does not fit Trike models.

B. FL TOURING CLEAN FRONT FENDER

With no holes, this fender provides the starting point for customization. Offered in primed finish and ready to bolt onto existing brackets.

59045-00B **\$299.95**
Fits '94-'13 FLHR and '89-'13 FLT and FLHT models.

C. STREET STALKER® FRONT FENDER KIT*

The smooth curves of the Street Stalker® Front Fender easily create a clean, custom front-end look. Made from high-impact, injection-molded composite materials. Includes mounting hardware.

Fits '86-later FL Softail® models (except Springer™). Also fits '00-later Touring models (except models equipped with fairing lowers) with separate purchase of Fender Adaptor Kit P/N 59013-02A or P/N 58900085.

59397-98 Primed. **\$134.95**

59397-03DH Vivid Black. **\$199.95**



A. FRONT FENDER ADAPTER KIT – '14-LATER MODELS



A. FRONT FENDER ADAPTER KIT – '00-'13 MODELS



B. FL TOURING CLEAN FRONT FENDER

C. STREET STALKER FRONT FENDER KIT – VIVID BLACK

*NOTE: This product is a "Paint to Order" accessory. Please allow for an average of 5 weeks delivery for this item.

Notice: The prices appearing in this catalog are the manufacturer's suggested retail prices. Actual retail prices may vary.

TOURING & TRIKE 455

Chassis Trim



D. WATER PUMP COVER – CHROME



D. WATER PUMP COVER – CHROME

Dress the Twin-Cooled™ Touring model's Water Pump Cover in style. This Chrome Water Pump is designed to hug the contours of the water pump, and conceals many of the coolant lines and fittings for a custom look. A direct replacement for the Original Equipment black plastic cover, this kit can be installed in minutes.

61400225 **\$74.95**

Fits '14-later FLHTCU, FLHTCUL, FLHTK, FLHTKL and FLHTCUTG models equipped with Twin-Cooled engines.

E. OIL COOLER COVER KIT – CHROME

Dress the Touring and Trike oil cooler in style. This chrome Oil Cooler Cover is designed to hug the contours of the cooler body while allowing complete airflow across the surface. Kit includes required mounting hardware.

63121-11A **\$59.95**

Fits '11-later Touring and Trike (except models equipped with Twin-Cooled engines).

25700007 **\$59.95**

Fits '09-'10 Touring and Trike models.

62995-04 **\$59.95**

Fits '99-'06 Touring models equipped with Touring Oil Cooler Kit P/N 62895-03A.

F. VOLTAGE REGULATOR COVER – CHROME

This chrome-plated steel cover features an open-faced design to allow airflow through the voltage regulator. Chrome-plated mounting hardware included.

74538-09 **\$44.95**

Fits '09-'13 Touring (except models with oil coolers). Will not fit models equipped with a sidecar.

74543-00 **\$44.95**

Fits '97-'08 Electra Glide®, Road Glide® and Road King® (except models with oil coolers). Will not fit '07-later models equipped with a sidecar.

G. VOLTAGE REGULATOR – CHROME

Original Equipment voltage regulators with a sparkling triple-plated chrome finish. Hand-buffed, then copper-, nickel- and chrome-plated, these brilliant chrome-plated regulators are the perfect highlight for any Harley-Davidson® motorcycle.

74622-09 **\$179.95**

Fits '09-later Touring and Trike models (except '14-later FLHTKSE, FLHRSE and '15-later FLTRUSE and FLHXSE).

74622-06 **\$179.95**

Fits '06-'08 Touring models.

74622-04 **\$179.95**

Fits '04-'05 Touring models.

74537-93A **\$149.95**

Fits '89-'95 1340 models, '96 FLT, FLHT and FLHR models (except fuel injected), '96-'99 Softail® and '96-'98 Dyna® models.

H. FUEL TANK MOUNTING HARDWARE KIT – CHROME

Beauty lies in the details, and this chrome-plated Fuel Tank Mounting Hardware Kit ensures you won't leave this one overlooked. The perfect finishing touch to your fuel tank, the kit includes the "Bullet Tip" custom bolts and machined washers required for the specific model application. Hardware design matches the Chrome Bullet Tip Footpeg Bolt Kit P/N 94133-01 and other available accessories.

62920-00A **\$39.95**

Fits '98-later Touring and Trike models.



E. OIL COOLER COVER KIT – CHROME ('11-LATER MODELS SHOWN)



E. OIL COOLER COVER KIT – CHROME ('99-'06 MODELS SHOWN)



F. VOLTAGE REGULATOR COVER – CHROME ('09-'13 MODELS SHOWN)



F. VOLTAGE REGULATOR COVER – CHROME ('97-'08 MODELS SHOWN)



G. VOLTAGE REGULATOR – CHROME



H. FUEL TANK MOUNTING HARDWARE KIT – CHROME

TOURING

Notice: The prices appearing in this catalog are the manufacturer's suggested retail prices. Actual retail prices may vary.

456 TOURING & TRIKE

Headlamp Trim

A. GLOSS BLACK NACELLE AND HANDLEBAR COVER KIT

The classic Harley-Davidson® motorcycle color is black. It shows your attitude, your feelings and your desire to be different from the rest. These gloss black accessories are the ultimate extension of the Harley-Davidson philosophy. Manufactured from Original Equipment components, these parts provide superior fit and finish. Complete the look with a Gloss Black Headlamp Trim Ring P/N 46555-03B (sold separately).

46547-03A \$299.95
Fits '94-'13 FLHR and FLHRC models.

B. HEADLAMP TRIM RINGS – GLOSS BLACK

Finish the Dark Custom™ look by replacing the Original Equipment chrome headlamp trim ring with sinister black. Easy to install, the ring's rich black surface matches the stock headlamp shell finish for a unified look.

46555-03B 7" Headlamp. \$34.95
Fits '94-'14 Touring models (except Road Glide®).

67700117 4" Passing Lamp. \$46.95
Fits '62-later models equipped with Original Equipment or accessory Auxiliary Lamp Kits. Sold in pairs.

C. HEADLAMP TRIM RING – BURST COLLECTION

Sculpted machining sends reflections of light in all directions. This Headlamp Trim Ring features a rich black anodized finish that is machined to expose the highlights of raw aluminum. The contrasting cut-back look makes a powerful visual statement, and works great with both traditional and contemporary customizing styles. Easy to install.

61400149 \$139.95
Fits '96-'13 Electra Glide®, Street Glide® and Trike models. (except FLHTCUSE6/7/8 or FLHXSE2). Does not fit with Fairing Bra P/N 57800-00. Does not fit with accessory headlamps 67700040A, 73390-10A or 90050-02A.

Shown with:

AUXILIARY LAMP TRIM RINGS – BURST COLLECTION

Lamp Trim Rings feature a rich black anodized finish that is machined to expose the highlights of raw aluminum. Easy to install.

61400255 Auxiliary Lamps. \$199.95
Fits '62-later models equipped with Original Equipment or accessory Auxiliary Lamp Kits. Sold in pairs.



**A. GLOSS BLACK NACELLE AND HANDLEBAR COVER KIT
(SHOWN WITH GLOSS BLACK HEADLAMP TRIM RING)**



B. HEADLAMP TRIM RINGS – GLOSS BLACK



C. HEADLAMP TRIM RING – BURST COLLECTION

Notice: The prices appearing in this catalog are the manufacturer's suggested retail prices. Actual retail prices may vary.

TOURING & TRIKE 457

Fairing Trim

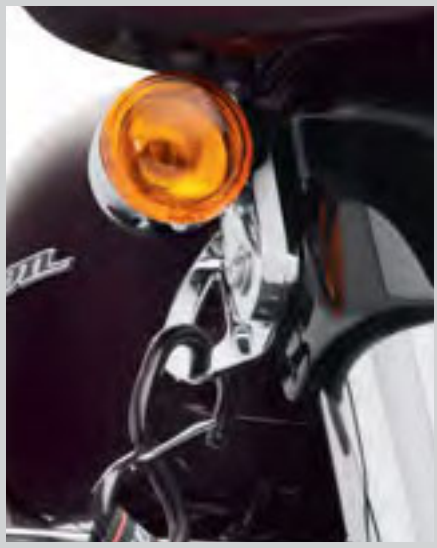

D. TIE-DOWN BRACKETS – CHROME



D. TIE-DOWN BRACKETS – '14-LATER MODELS



D. TIE-DOWN BRACKETS – '95-LATER MODELS



E. OUTER FAIRING SKIRT – GLOSS BLACK



E. OUTER FAIRING SKIRT – '14-LATER MODELS



E. OUTER FAIRING SKIRT – '87-'13 MODELS



F. ROAD GLIDE FAIRING SUPPORT KIT – GLOSS BLACK



G. LOWER TRIPLE TREE COVER – CHROME

D. TIE-DOWN BRACKETS – CHROME

Simplify the process of securing your bike to a trailer or bike lift. These stylish chrome Tie-Down Brackets mount cleanly to the front fork cover and offer a secure method to connect tie-down straps. Moving the tie-down point from the handlebar to the triple-tree area reduces wear on the handlebar bushings and ensures a consistent easy-to-access mounting point. Just add Harley-Davidson® Ratchet Straps and Soft Hooks and you're ready to go.

93500011 **\$59.95**
Fits '14-later Touring models (except Road Glide® and Road King®). Does not fit Trike models.

93500006 **\$59.95**
Fits '00-later FLS, FLSTC and FLSTF/B, '95-later FLHR, FLHRC, '95-'13 FLHT, FLHTC, FLHX, FLHXSE/2/3 and '10-'13 FLHTCU, FLHTK and FLHTCUSE4/5/6/7. FLS, FLSTF and FLSTFB models without a windshield require separate purchase of Hardware Kit P/N 91800030.

E. OUTER FAIRING SKIRT – GLOSS BLACK

Add a sinister touch to your batwing fairing. This classic gloss black skirt replaces the Original Equipment chrome or color-matched trim below the headlamp. The black skirt visually slims the fairing, and is the ideal finishing element on a blacked-out bike. Manufactured from Original Equipment components for superior fit and finish.

57100227 **\$59.95**
Fits '14-later Electra Glide® and Street Glide® models.

46559-03 **\$99.95**
Fits '87-'13 Touring models. Will not fit with Braided Brake Line P/N 45212-97B. Use Braided Brake Line P/N 46231-02A.

F. ROAD GLIDE FAIRING SUPPORT KIT – GLOSS BLACK

Take your Road Glide in a different direction. Easy to install Fairing Mount replaces the Original Equipment chrome edition, and forms a seamless gloss black transition between a black engine guard and a dark color fairing. Kit includes gloss black left and right fairing support and matching engine guard clamps.

47200278 **\$169.95**
Fits '15-later Road Glide® models.

G. LOWER TRIPLE TREE COVER – CHROME

This Lower Triple Tree Cover dresses up the unfinished underside of the triple tree for a complete custom look. The chrome-plated steel cover installs easily, concealing the brake splitter fitting.

66050-03 **\$69.95**
Fits '87-'13 Touring models. Will not fit with Braided Brake Line P/N 45212-97B. Use Braided Brake Line P/N 46231-02A.

TOURING

Notice: The prices appearing in this catalog are the manufacturer's suggested retail prices. Actual retail prices may vary.

458 TOURING & TRIKE

Fairing Trim

A. BATWING COLOR-MATCHED INNER FAIRING KIT

Add a custom touch to your motorcycle with a Color-Matched Inner Fairing and Fairing Cap. Designed to replace the Original Equipment matte black inner fairing, the color-matched finish offers a brilliant contrast to the gauge faces and accessory chrome instrument bezels.

Available to fit:

Fits '14-later Electra Glide® and Street Glide® models with handlebar mounted mirrors. Kit includes inner fairing, fairing cap, and media door.

Fits '14-later Street Glide models with fairing mounted mirrors. Kit includes inner fairing, fairing cap, and media door.

Fits '08-'13 Electra Glide and Street Glide models. Kit includes inner fairing and fairing cap.

Fits '04-'07 Electra Glide and Street Glide models. Kit includes inner fairing and fairing cap.

Fits '14-later Tri Glide® models. Kit includes inner fairing, fairing cap, and media door.

Fits '09-'13 Trike models. Kit includes inner fairing and fairing cap.

Fits '06-'13 Road Glide® models. Kit includes inner fairing, instrument housing and glove box doors.

See page 804-805 for a complete list of color options.



A. BATWING COLOR-MATCHED INNER FAIRING – '14-LATER MODELS



A. BATWING COLOR-MATCHED INNER FAIRING – '04-'13 MODELS

Notice: The prices appearing in this catalog are the manufacturer's suggested retail prices. Actual retail prices may vary.

NEW

TOURING & TRIKE 459

Fairing Trim



**B. ROAD GLIDE COLOR-MATCHED INNER FAIRING KIT – '15-LATER MODELS
(SHOWN WITH COLOR-MATCHED FAIRING AIR DUCT)**

B. ROAD GLIDE® COLOR-MATCHED INNER FAIRING KIT
Add a custom touch to your motorcycle with a Color-Matched Inner Fairing and Fairing Cap. Designed to replace the Original Equipment matte black inner fairing, the color-matched finish offers a brilliant contrast to the gauge faces and accessory chrome instrument bezels.

Available to fit:

Fits '15-later Road Glide® models. Kit includes Color-Matched Inner Fairing Air Duct (sold separately).

Fits '06-'13 Road Glide models. Kit includes inner fairing, instrument housing and glove box doors.

See page 805 for a complete list of color options.

Also available:

ROAD GLIDE COLOR-MATCHED FAIRING AIR DUCT
Add a custom touch to your motorcycle with a Color-Matched Inner Fairing Duct. Designed to replace the Original Equipment matte black inner fairing duct, the color-matched finish offers a brilliant contrast to the gauge faces and accessory chrome instrument bezels. Kit includes air duct baffle and actuator assembly.

Fits '15-later Road Glide models. Color-Matched Inner Fairing (sold separately).

See page 805 for a complete list of color options.



B. ROAD GLIDE COLOR-MATCHED INNER FAIRING – '06-'13 MODELS

Notice: The prices appearing in this catalog are the manufacturer's suggested retail prices. Actual retail prices may vary.

460 TOURING & TRIKE

Fairing Trim

A. INNER FAIRING TRIM KIT

Add a touch of luxury and style to your dash. This complete kit dresses the inner fairing by surrounding the radio faceplate and front speakers with chrome. Self-adhesive bezels surround the gauges and the gloss black fascia completes the stylish look. Kit includes Gauge Trim Kit, Radio Faceplate Trim and two Front Speaker Trim Rings.

61400199 **\$139.95**

Fits '14-later Electra Glide®, Street Glide® and Tri Glide® models. Does not fit CVO™ models or models equipped with accessory Boom!™ Audio Fairing Speakers.

B. GAUGE TRIM KIT

A touch of chrome makes all the difference. These classic gauge bezels take just a few minutes to install, and add the beauty of chrome to your dash. Trim rings are formed to the gauge shapes and feature peel-and-stick adhesive backing for permanent installation. Kit includes chrome gauge trim rings and a gloss black mounting plate.

61400200 **\$89.95**

Fits '14-later Electra Glide, Street Glide and Tri Glide models.

C. RADIO TRIM BEZEL

This chrome faceplate trim accents the center section of the inner fairing and highlights the radio. Trim is formed to the radio surround and feature peel-and-stick adhesive backing for simple, permanent installation.

61400201 **\$27.95**

Fits '14-later Electra Glide, Street Glide and Tri Glide models.



A. INNER FAIRING TRIM KIT



A. INNER FAIRING TRIM KIT



B. GAUGE TRIM KIT



C. RADIO TRIM BEZEL

Notice: The prices appearing in this catalog are the manufacturer's suggested retail prices. Actual retail prices may vary.

TOURING & TRIKE 461

Fairing Trim



D. GAUGE BEZEL KIT – BURST COLLECTION

D. GAUGE BEZEL KIT – BURST COLLECTION

Complete the custom look of the inner fairing. Burst Collection Gauge Bezels feature contrasting gloss black and sculpted machined surfaces that send reflections of light in all directions. The perfect match for Burst Speaker Trim, this easy to install gauge bezel kit includes two 4.0" Speedometer and Tachometer bezels and four 2.0" auxiliary gauge bezels.

61400260

\$226.95

Fits '96-'13 Electra Glide®, Street Glide®, Road Glide® and Trike models.

E. SPEAKER TRIM – BURST COLLECTION

Sculpted machining sends reflections of light in all directions. The Burst Collection Speaker Trim features a rich black anodized finish that is machined to expose the highlights of raw aluminum. The contrasting cut-back spider makes a powerful visual statement, and works great with both traditional and contemporary customizing styles. Burst Collection Speaker Trim fits with both Original Equipment and Boom! Audio Speakers. Kit includes mounting hardware. Sold in pairs.

76000307 Batwing Fairing.

\$139.95

Fits '96-'13 Electra Glide, Street Glide and Trike models with Original Equipment or Boom! Audio Fairing Mount Speakers. Does not fit '11-'12 FLHXSE. Does not fit Tour-Pak® or Fairing Lower Speakers.

76000522 Tour-Pak Speakers.

\$221.95

Fits '96-'13 Electra Glide, Road Glide and Tri Glide® models with Original Equipment or Boom! Audio Tour-Pak mounted speakers.



D. GAUGE BEZEL KIT – BURST COLLECTION



E. FAIRING SPEAKER TRIM – BURST COLLECTION



E. TOUR-PAK SPEAKER TRIM – BURST COLLECTION

Notice: The prices appearing in this catalog are the manufacturer's suggested retail prices. Actual retail prices may vary.

462 TOURING & TRIKE

Fairing Trim

A. DIAMOND ICE GAUGE TRIM RINGS

These Gauge Trim Rings add a fine line of rhinestones around the perimeter of the gauge face, and a deluxe finishing touch to the dash. Chrome-plated rings feature adhesive backing for easy press-in-place installation.

74736-10 4" Gauge. **\$28.95**

Fits speedometers and tachometers on '05-'06 FXDC, '10-later FXDWG, '00-later XL, FXDL, FXDB, FXD, FXS, '13-later FXSB, FXSBSE, and '00-'13 Electra Glide®, Street Glide®, Road Glide® and Trike models. Sold individually.

74737-10 2" Gauge. **\$23.95**

Fits Voltmeter, Oil Pressure, Air Temp and Fuel Gauge on '86-'13 Electra Glide, Street Glide, Road Glide and Trike models. Sold individually.

61400035 Dash Indicator Light. **\$19.95**

Fits '96-later FXS and '96-'13 Electra Glide, Street Glide and Trike models.

B. DIAMOND ICE SPEAKER TRIM

Add a fine line of rhinestones around the perimeter of the Original Equipment speaker, and a little bit of flash to the dash and rear speaker boxes. These chrome-plated trim bezels mount directly over the speaker grills, and complement the complete line of Diamond Ice accessories. Easy to install, the kit includes left and right speaker trim and required mounting supplies.

61400033 Front. **\$69.95**

Fits '96-'13 Electra Glide, Street Glide and Trike models with Original Equipment Speaker Grills. Does not fit '11-'12 FLHXSE or models equipped with Boom!™ Audio High Performance Speakers.

61400034 Rear. **\$64.95**

Fits '98-'13 FLHTCU, FLHTK and FLHTCUTG models. Does not fit models equipped with Boom! Audio High Performance Speakers.



A. DIAMOND ICE GAUGE TRIM RINGS



A. DIAMOND ICE GAUGE TRIM RINGS



B. DIAMOND ICE SPEAKER TRIM – FRONT

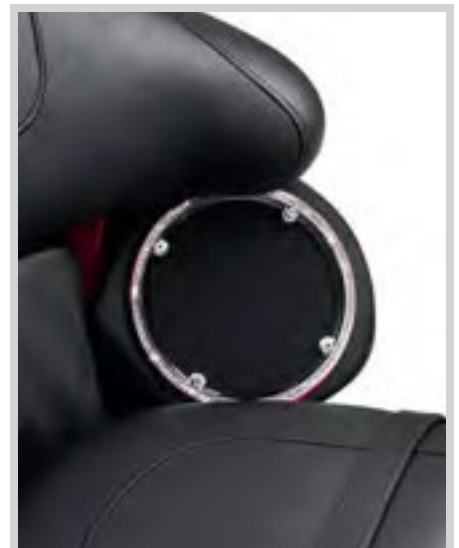

B. DIAMOND ICE SPEAKER TRIM – REAR

Notice: The prices appearing in this catalog are the manufacturer's suggested retail prices. Actual retail prices may vary.

TOURING & TRIKE 463

Fairing Trim



**C. INNER FAIRING TRIM KIT
(SHOWN WITH FAIRING DASH PAD)**



C. INNER FAIRING TRIM KIT



**D. CHROME INSTRUMENT BEZELS
(SHOWN WITH FAIRING DASH PAD)**

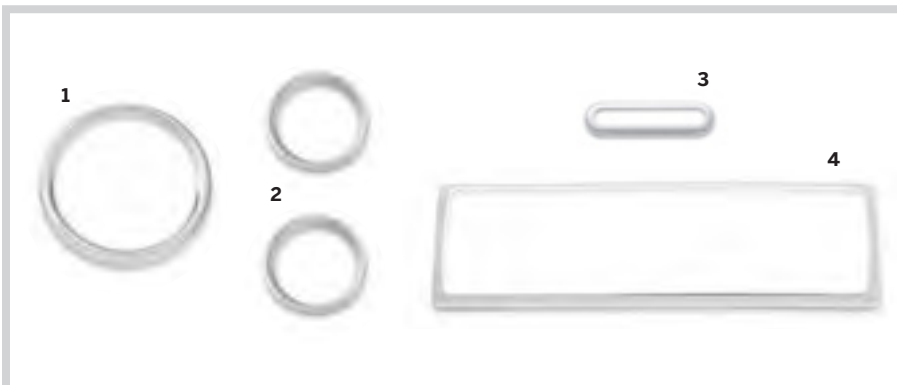

D. CHROME INSTRUMENT BEZELS

C. INNER FAIRING TRIM KIT

Add a touch of luxury and style to your dash. This complete kit dresses the inner fairing by surrounding the radio faceplate and gauges with chrome. Package includes: Bar & Shield Radio Faceplate, two 4.0" Speedo/Tach Gauge Bezels, four 2.0" Gauge Bezels, Radio and Gauge Faceplate Trim and two Front Speaker Trim Rings.

96396-09 \$119.95

Fits '06-'13 Electra Glide®, Street Glide® and Trike models equipped with the Advanced Audio System Radio.

D. CHROME INSTRUMENT BEZELS

A touch of chrome makes all the difference. These bezel covers take just seconds to install and add the beauty of chrome to your dash. Available to fit all the fairing-mount gauges, these easy-to-install, chrome-plated formed rings feature peel-and-stick adhesive backing for permanent installation.

1. 4" Chrome Gauge Bezel

74541-00 \$16.95

Fits Speedometer and Tachometer Gauges on '00-later XL, '00-'13 Dyna® (except FLD and FXDWG), '13-later FXSB, FXSBSE, and '00-'13 Electra Glide, Street Glide, Road Glide® and Trike Models. Sold individually.

1. 4" Chrome Gauge Bezel

74560-96 \$22.95

Fits Speedometer and Tachometer on '96-'99 FLHT and '98-'99 FLTR models. Sold in pairs.

2. 2" Chrome Gauge Bezel

74550-92T \$18.95

Fits Voltmeter, Oil Pressure, Air Temp and Fuel Gauge on '86-'13 Electra Glide, Street Glide, Road Glide and Trike models (pair). Sold in pairs.

3. Chrome Indicator Lamp Bezel Cover

74562-98 \$16.95

Fits '96-'13 Electra Glide, Street Glide and Trike models.

4. Chrome Radio Trim Bezel

74596-00 \$17.95

Fits '98-'05 FLHTC and FLHTCU models. Also fits FLHT models with accessory radio.

464 TOURING & TRIKE

Fairing Trim

A. FAIRING DASH PAD

Original Equipment on the Screamin' Eagle® Electra Glide® Ultra model, this custom dash pad adds a recessed cockpit look to the inner fairing. The smooth top-stitched leather visor features a brilliant chrome-plated gauge eyebrow for a custom touch.

58262-05 **\$174.95**
Fits '97-'13 Electra Glide®, Street Glide® and Trike models.



A. FAIRING DASH PAD

B. RADIO AND GAUGE FACEPLATE TRIM

This chrome faceplate trim is installed on the raised section of the inner fairing and highlights the air temperature gauge, oil pressure gauge, indicator lamp and the radio. Trim can be installed with Chrome Instrument Gauge Bezels P/N 74550-92T for an added custom touch.

74612-06 **\$28.95**
Fits '96-'13 Electra Glide, Street Glide and Trike models.

C. RADIO FACEPLATE TRIM

This brushed aluminum radio faceplate features self-adhesive installation on any model equipped with the Advanced Audio System Radio.

77142-06 Skull. **\$16.95**
Fits '06-'13 Touring models equipped with Advanced Audio System Radio.

77143-07 Bar & Shield. **\$16.95**
Fits '06-'13 Touring models equipped with Advanced Audio System Radio.

D. SWITCH PANEL ACCENT

Dress for success. This handsome trim element frames the ignition and flanking rocker switches in chrome. Simple to install with peel-and-stick adhesive, the kit also includes inserts to cover inactive switch openings. Complete the chrome look with optional Radio Trim P/N 74612-06 and Chrome Gauge Bezels.

61400001 **\$54.95**
Fits '96-'13 Electra Glide, Street Glide and Trike models.



B. RADIO AND GAUGE FACEPLATE TRIM



C. SKULL RADIO FACEPLATE TRIM



C. SKULL AND BAR & SHIELD LOGO RADIO FACEPLATE TRIM



D. SWITCH PANEL ACCENT

Notice: The prices appearing in this catalog are the manufacturer's suggested retail prices. Actual retail prices may vary.

TOURING & TRIKE 465

Fairing Trim



E. SPEAKER TRIM – FRONT
(*14-LATER MODELS)



E. SPEAKER TRIM – REAR
(*14-LATER MODELS)



E. SPEAKER TRIM – FRONT
(*96-'13 MODELS)



E. SPEAKER TRIM – REAR
(*98-'13 MODELS)



F. BOOM! AUDIO SPEAKER TRIM – FRONT
(*14-LATER MODELS)



F. BOOM! AUDIO SPEAKER TRIM – REAR
(*14-LATER MODELS)



F. BOOM! AUDIO SPEAKER TRIM – FRONT
(*98-'13 MODELS)



F. BOOM! AUDIO SPEAKER TRIM – REAR
(*98-'13 MODELS)

E. SPEAKER TRIM – CHROME

When it comes to style, this chrome-plated trim makes your speakers look as good as they sound. These bezels mount directly over the Original Equipment speaker grills, and add a subtle spot of chrome. Easy to install, the kit includes left and right speaker trim and required mounting supplies.

61400197 Front. **\$39.95**
Fits '14-later Electra Glide®, Street Glide® and Tri Glide® models with Original Equipment speakers. Does not fit CVO™ FLHTKSE models or models equipped with Boom!™ Audio High Performance Speakers.

61400194 Rear. **\$39.95**
Fits '14-later FLHTCU, FLHTCUL, FLHTK, FLHTKL and FLHTCUTG models with Original Equipment Tour-Pak® speakers. Does not fit CVO FLHTKSE, FLTRUSE or models equipped with Boom! Audio High Performance Speakers.

74504-99 Front. **\$32.95**
Fits '96-'13 Electra Glide, Street Glide and Trike models with Original Equipment Speaker Grills. Does not fit '11-'13 FLHXSE, '12-'13 FLHTCUSE or models equipped with Boom! Audio High Performance Speakers.

74584-99 Rear. **\$35.95**
Fits '98-'13 FLHTCU, FLHTK and FLHTCUTG models. Does not fit '12-'13 FLHTCUSE or models equipped with Boom! Audio High Performance Speakers.

F. BOOM! AUDIO SPEAKER TRIM

Add a touch of chrome to your Boom! Audio Speakers. Chrome trim rings outline the speaker and accent the rich black speaker grill. Easy to install, the trim rings complement available chrome fairing trim. Sold in pairs.

61400193 Front. **\$44.95**
Fits '14-later Electra Glide, Street Glide and Tri Glide models with Boom! Audio Fairing Mount Speakers.

61400210 Rear. **\$44.95**
Fits '14-later Electra Glide, Street Glide and Tri Glide models with Rear Speaker Pods and Boom! Audio Tour-Pak Rear Speakers.

76000156 Front. **\$39.95**
Fits '98-'13 Electra Glide, Street Glide and Trike models equipped with Boom! Audio Fairing Mount Speakers.

76000157 Rear. **\$39.95**
Fits '98-'13 Touring models with Rear Speaker Pods and Boom! Audio Tour-Pak Rear Speakers.

466 TOURING & TRIKE

Fairing Trim

A. FAIRING MOUNT MIRRORS – BLACK

Fairing Mount Mirrors offer a truly innovative look from the traditional handlebar-mounted mirrors. Mounting just inside the inner fairing, the molded plastic mirror housings complement the contours of the batwing fairing. They provide a wide range of adjustability and feature convex mirror glass that maximizes your field of view. The Bar & Shield logo is carefully laser-etched on each mirror glass. Kit includes necessary hardware, instructions and mounting template for easy installation.

56000076 **\$99.95**

Fits '14-later Electra Glide® and Tri Glide® models. Original Equipment on Street Glide® models.

91945-98B **\$99.95**

Fits '96-'13 Electra Glide and Trike models. Original equipment on Street Glide models.



A. FAIRING MOUNT MIRRORS – BLACK

B. FAIRING MOUNT MIRRORS – CHROME

Add a splash of chrome to the batwing inner fairing. These Fairing Mount Mirrors de-clutter the handlebar and add a contemporary aero style to your ride. The attractive chrome housing provides a custom look, and the convex mirror and wide range of adjustment maximizes your field of view. A direct bolt-on replacement for Original Equipment fairing mount mirrors, the kit includes the hardware and mounting template required for easy and accurate installation on many models.

56000077 **\$134.95**

Fits '14-later Electra Glide, Street Glide and Tri Glide models.

56000029 **\$134.95**

Fits '96-'13 Electra Glide, Street Glide and Trike models. Original Equipment on '12 FLHXSE models.



B. FAIRING MOUNT MIRRORS – CHROME

C. ILLUMINATED FAIRING MOUNT MIRROR COVERS – CHROME

Add auxiliary LED turn signals and a splash of chrome to the inner fairing. The perfect finishing touch to a fully-dressed inner fairing, these chrome-plated mirror housings feature fast-acting amber LED turn signals at the outer edge. Side turn signals attract attention from the drivers around you, and the plug-in, no-splice design simplifies installation.

56000084 **\$134.95**

Fits '14-later Touring and Trike models with fairing mount mirrors. Does not fit with Split Vision Fairing Mount Mirrors P/N 92085-10.

92600-10 **\$134.95**

Fits '06-'13 FLHX, FLHXSE and FLHXXX models, and other Electra Glide models equipped with Fairing Mount Mirrors P/N 91945-98B. Does not fit with Split Vision Fairing Mount Mirrors P/N 92085-10.



C. ILLUMINATED FAIRING MOUNT MIRROR COVERS – CHROME

D. SPLIT VISION FAIRING MOUNT MIRRORS

See even more of the world that you just passed. These exclusive-design Split Vision Mirrors minimize blind spots and provide a wide panoramic rear view of the left and right lane, and the road behind you. The mirrors feature a large primary panel for normal view, and a second outboard convex panel for a wider field of vision. Slightly larger than the standard-view Fairing Mount Mirrors, these Split Vision Mirrors offer the same full range of adjustability. A direct bolt-on replacement for standard-view Fairing Mount Mirrors, the kit also includes the hardware and mounting template required for easy and accurate installation on many models.

92085-10 **\$109.95**

Fits '96-'13 Electra Glide, Street Glide and Tri Glide models.

Does not fit with Chrome Fairing Mount Mirror Covers P/N 91924-09, Illuminated Chrome Mirror Covers P/N 92600-10 or Fairing Mount Mirror Covers P/N 92200001.



D. SPLIT VISION FAIRING MOUNT MIRRORS

E. FAIRING MOUNT MIRROR COVERS – CHROME

Add a splash of chrome to the inner fairing. The chrome-plated housings wrap around the back and side of the Fairing Mount Mirrors, presenting a clean, uncluttered profile. The perfect finishing touch to a fully dressed inner fairing.

91924-09 **\$74.95**

Fits '06-'13 FLHX, FLHXSE and FLHXXX models, and other Electra Glide models equipped with Fairing Mount Mirrors P/N 91945-98B. Does not fit with Split Vision Fairing Mount Mirrors P/N 92085-10.



E. FAIRING MOUNT MIRROR COVERS – CHROME

Notice: The prices appearing in this catalog are the manufacturer's suggested retail prices. Actual retail prices may vary.

TOURING & TRIKE 467

Console Trim



F. GLOSS BLACK CONSOLE KIT
(70900463 SHOWN)
(SHOWN WITH BURST FUEL DOOR)



F. GLOSS BLACK CONSOLE KIT
(70900501 SHOWN)
(SHOWN WITH BLACK FUEL DOOR)

F. GLOSS BLACK CONSOLE KIT

Lead the way to the dark side. This blacked-out Console Kit includes the major components required to change the chrome console to a dark custom look. Manufactured from Original Equipment components for superior fit and finish, the kit includes black console, gasket, and hardware. Available for models with or without 7-pin DIN headset connector. Add your choice of Fuel Door (sold separately) to set your bike apart from the crowd.

Fits '08-later Electra Glide®, Street Glide®, Road Glide® and Trike models with center fill tank.

70900463 Without CB Communications Port. **\$299.95**

70900501 With CB Communications Port. **\$299.95**

G. FUEL TANK CONSOLE – CHROME

Visually stretch the look of the fuel tank with this full-length tank console. This die-cast console has been polished and chrome-plated to a mirror-like finish, and is capped off with a satin and gloss black Bar & Shield insert. The kit is a direct replacement for the Original Equipment console, and can be used with the stock fuel door, or accented with any of the Harley-Davidson® accessory collection doors. Kit includes all necessary mounting hardware.

71288-03A **\$204.95**

Fits '97-'07 FLHT, FLHTC and '98-'07 FLTR models.

Installation requires the use of a Road King® style seat. Will not fit FLHT or FLHTC models equipped with a CB Intercom Kit.

H. CB INTERCOM CHROME CONSOLE

Add a sweep of style to your fuel tank. This chrome-plated console is a direct replacement for the Original Equipment black finish CB console. The easy-to-install console features a plug-in connection for the CB microphone.

77140-05 Fits '03-'07 FLHTCUI models. **\$84.95**

I. PERSONAL ACCENTS CONSOLE INSERT COLLECTIONS

As a rider, there is probably no part of your bike you see more than your dash and tank console. And thanks to Personal Accents Inserts, it's also the easiest part of your bike to customize. Console inserts are available in a stylish assortment of finishes that blend with your personal direction. Matching Tour-Pak® Inserts are also available to complete the custom transformation.

See style and fitment information in Color-Shop section of this catalog.



G. FUEL TANK CONSOLE – CHROME



H. CB INTERCOM CHROME CONSOLE



I. PERSONAL ACCENTS CONSOLE INSERT COLLECTIONS – RAISED SKULL

Notice: The prices appearing in this catalog are the manufacturer's suggested retail prices. Actual retail prices may vary.

468 TOURING & TRIKE

Console Trim

A. FUEL TANK CONSOLE DOOR – BURST COLLECTION

Rich black surfaces and prismatic machined aluminum define the Burst Collection Fuel Door. The race-track ridges and the inner spider design make a powerful visual statement, and are the perfect match to the available Gloss Black Console and Smooth Push Button accessories. Kit includes mounting hardware.

70900474 **\$139.95**

Fits '08-later Electra Glide®, Street Glide®, Road Glide® and Trike models with center fill tank.



A. FUEL TANK CONSOLE DOOR – BURST COLLECTION



B. FUEL TANK CONSOLE DOOR – GLOSS BLACK

B. FUEL TANK CONSOLE DOOR – GLOSS BLACK

The gloss black fuel door is the perfect match for the Gloss Black Console Kit. The easy-to-install fuel door replaces the stock door, and reuses Original Equipment mounting hardware.

70900465 **\$54.95**

Fits '08-later Electra Glide, Street Glide, Road Glide and Trike models with center fill tank.

C. WILLIE G SKULL FUEL TANK CONSOLE DOOR

Add a little attitude to your ride. Styled to complement Harley-Davidson® Skull accessory items, the menacing raised skull with black-filled eyes leaps from a field of chrome. The surrounding “Harley-Davidson Motorcycles” script is the perfect finishing touch. These easy-to-install Fuel Doors replace the stock door, and reuse Original Equipment mounting hardware and lock.

61308-09 **\$36.95**

Fits '08-later Electra Glide, Street Glide, Road Glide and Trike models with center fill tank.

61374-04 **\$36.95**

Fits '92-'07 Electra Glide, Tour Glide™ and Road Glide models.



C. WILLIE G SKULL FUEL TANK CONSOLE DOOR



D. NUMBER ONE SKULL FUEL TANK CONSOLE DOOR

D. NUMBER ONE SKULL FUEL TANK CONSOLE DOOR

The sinister Harley-Davidson #1 Skull logo dresses for a night on the town. This complete die-cast aluminum collection has been polished and chrome-plated to a brilliant shine, then finished with a contrasting black-filled Dark Custom™ Skull logo. These easy-to-install Fuel Doors replace the stock door, and reuse Original Equipment mounting hardware and lock.

62378-10 **\$36.95**

Fits '08-later Electra Glide, Street Glide, Road Glide and Trike models with center fill tank.

E. “LIVE TO RIDE” FUEL TANK CONSOLE DOOR

“Live To Ride, Ride to Live.” It has become the motto of the Harley-Davidson nation, accompanying riders over millions of miles of travel. This collection is a tribute to that way of life. These easy-to-install Fuel Doors replace the stock door, and reuse Original Equipment mounting hardware and lock. Available in your choice of gold or chrome finish.

Fits '08-later Electra Glide, Street Glide, Road Glide and Trike models with center fill tank.

61335-09 Gold. **\$39.95**

61300049 Chrome. **\$36.95**

Fits '92-'07 Electra Glide, Tour Glide1 and Road Glide models.

61286-92T Gold. **\$39.95**



E. “LIVE TO RIDE” FUEL TANK CONSOLE DOOR – GOLD



F. “LIVE TO RIDE” FUEL TANK CONSOLE DOOR – CHROME

F. FLAMES FUEL TANK CONSOLE DOOR

Ever since they began emerging on gas tanks a few decades ago, flames have been a symbol of custom styling. Now, Harley-Davidson continues the tradition with the Flames Collection. These easy-to-install Fuel Doors replace the stock door, and reuse Original Equipment mounting hardware and lock. Available in your choice of gold or chrome finish.

Fits '08-later Electra Glide, Street Glide, Road Glide and Trike models with center fill tank.

61319-09 Gold. **\$39.95**

61300050 Chrome. **\$36.95**

Fits '92-'07 Electra Glide, Tour Glide and Road Glide models.

61359-98 Gold. **\$39.95**



F. FLAMES FUEL TANK CONSOLE DOOR – GOLD



F. FLAMES FUEL TANK CONSOLE DOOR – CHROME

Notice: The prices appearing in this catalog are the manufacturer's suggested retail prices. Actual retail prices may vary.

TOURING & TRIKE 469

Console Trim



G. SKULL & CHAIN FUEL TANK CONSOLE DOOR – CHROME



H. SKULL & CHAIN FUEL TANK CONSOLE DOOR – SMOKEY CHROME



I. DIAMOND ICE FUEL TANK CONSOLE DOOR



J. SMOOTH PUSH-BUTTON FUEL TANK CONSOLE DOOR RELEASE – CHROME



J. SMOOTH PUSH-BUTTON FUEL TANK CONSOLE DOOR RELEASE – GLOSS BLACK



K. PUSH-BUTTON FUEL TANK CONSOLE DOOR RELEASE



G. SKULL & CHAIN FUEL TANK CONSOLE DOOR – CHROME

Links to the dark side. This mirror-chrome collection stands out in a crowd, with a contrasting 3-D chain that rims the surface and surrounds the distinctive raised Willie G Skull. Select from the traditional skull design or for a little added flash, choose the version with the bright rhinestone encrusted jaw line. Either way, this complete collection is a tribute to the mechanical side of your ride. These easy-to-install fuel doors replace the stock door, and reuse Original Equipment mounting hardware and lock.

Fits '08-later Electra Glide®, Street Glide®, Road Glide® and Trike models with center fill tank.

61100035	Skull.	\$59.95
61100009	Jeweled Skull.	\$59.95

H. SKULL & CHAIN FUEL TANK CONSOLE DOOR – SMOKEY CHROME

The sinister smokey-chrome finish is the ideal complement to a blacked-out ride and the contrasting 3-D chain rims the surface and surrounds the distinctive Willie G Skull with black-filled eyes. These easy-to-install fuel doors replace the stock door and reuse Original Equipment mounting hardware and lock.

Fits '08-later Electra Glide, Street Glide, Road Glide and Trike models with center fill tank.

61100033	Skull.	\$59.95
-----------------	--------	----------------

I. DIAMOND ICE FUEL TANK CONSOLE DOOR

This easy-to-install Fuel Door sets the rhinestone-laden Bar & Shield medallion "front and center" and attracts the maximum attention.

61307-10 **\$59.95**
Fits '08-later Electra Glide, Street Glide, Road Glide and Trike models with center fill tank.

J. SMOOTH PUSH-BUTTON FUEL TANK CONSOLE DOOR RELEASE

Add stop-and-go speed at the gas pump. The smooth button replaces the lock for push-to-open convenience. No more digging in your pocket for the key. The large button is easy to operate while wearing gloves.

53919-04A Chrome. **\$29.95**
Fits '92-later Electra Glide, Street Glide, Tour Glide™, Road Glide and Trike models with center fill tank.

90300096 Gloss Black. **\$29.95**
Fits '92-later Electra Glide, Street Glide, Tour Glide, Road Glide and Trike models with center fill tank.

K. PUSH-BUTTON FUEL TANK CONSOLE DOOR RELEASE

An added convenience you'll appreciate at fuel stops. This lockable replacement for your stock fuel tank console door lock allows the door to be opened without a key by depressing the center button of the lock. For basic security, it can be locked with any barrel key.

53842-00C **\$29.95**
Fits '92-later Electra Glide, Street Glide, Tour Glide, Road Glide and Trike models with center fill tank.

TOURING

Notice: The prices appearing in this catalog are the manufacturer's suggested retail prices. Actual retail prices may vary.

470 TOURING & TRIKE

Console Trim

A. FORK LOCK COVER

This chrome-plated aluminum die-cast cover finishes the look of the Road King® fork lock. The protective cover adds a finishing touch to the handlebar cover and the smooth domed lid flips up to provide access to the fork lock. Includes chrome-plated flush-mount hardware.

71790-05 Fits '94-later FLHR models. **\$49.95**



A. FORK LOCK COVER – CLOSED



A. FORK LOCK COVER – OPEN

B. GAUGE VISOR RING

A touch of chrome makes all the difference. These easy-to-install trim rings feature an integrated eyebrow visor to shield the gauge face from the sun's glare. Self-adhesive backing for secure mount.

74661-04 5" Gauge. **\$27.95**
Fits '99-'08 FXDWG, '99-'07 Road King and '99-later Softail® models (except FXS, FXSB, FXSBSE, FLSTNSE, FXST-Aus, FXSTD, FXCW, FXCWC, FLSTFSE and Softail models equipped with Chrome Console P/N 67575-04).

74662-04 4" Gauge. **\$25.95**
Fits '99-later XL, '99-'13 Dyna® (except FXDWG), FXS, FXSB, FXSBSE, FXST-Aus and '98-'13 Road Glide® models.



B. GAUGE VISOR RING



C. DIAMOND ICE TRIM RING – 5" GAUGE

C. DIAMOND ICE GAUGE TRIM RING

This Gauge Trim Ring adds a fine line of rhinestones around the perimeter of the gauge face and a deluxe finishing touch to the dash. Chrome-plated steel ring features adhesive backing for easy press-in-place installation.

74548-10 5" Gauge. **\$29.95**
Fits '99-'08 FXDWG, '99-later FXDF, FLD, '07-later FXDC, '99-'07 Road King and '99-later Softail models (except FXS, FXSB, FXSBSE, FXSTD, FXCW, FXCWC, FLSTFSE, FLSTNSE, FXST-Aus and Softail models equipped with chrome Console P/N 67575-04 or 71208-07).

D. "BULLSEYE" CONSOLE NUT

Replace your plain stock chrome acorn nut with this special chrome-plated Console Nut that features a machined "Bullseye" design highlighted with black accent rings.

94755-99 **\$7.95**
Fits '90-'95 and '00-later Softail models (except FXS, FXSB, FXSBSE, FXSTD, FXCW, FXCWC, FLSTSB, FXST-AUS and '09-later FLS and FLSTC), '93-'03 FXDWG, '94-'07 FLHR models.



D. "BULLSEYE" CONSOLE NUT

E. "BULLSEYE" CONSOLE WASHER

As a replacement for the plain stock washer on Road King models, this chrome-plated billet Console Washer features a three dimensional, machined-in "Bullseye" design, highlighted with black accent rings. A stainless steel mounting screw is provided and, once installed, is hidden under the black center insert with Bar & Shield logo.

94753-99 **\$19.95**
Fits '94-'07 FLHR (except FLHRS) models and '84-later Softail tank panels with screw mounts.



E. "BULLSEYE" CONSOLE WASHER

F. RIDER CUP HOLDER

Shaped to blend with the contours of your Harley-Davidson® motorcycle, this unique cup holder is easy to reach without cluttering the handlebar. The attractive chrome mount securely attaches to the frame downtube, and sweeps rearward to support the cup holder. The soft-touch insulated holder flexes to grip the beverage and features a perforated bottom to drain away rain water. Kit includes model-specific clamp, support rod, cup holder and all required mounting hardware.

50700001 **\$54.95**
Fits '09-later Touring and Trike models. Does not fit '14-later Touring or Trike models equipped with Fairing Lowers.



F. RIDER CUP HOLDER

Notice: The prices appearing in this catalog are the manufacturer's suggested retail prices. Actual retail prices may vary.

TOURING & TRIKE 471

Chassis Trim – Rear End



G. LOWER BELT GUARD COVER – CHROME
(60491-02A SHOWN)

G. LOWER BELT GUARD COVER – CHROME

Dress your lower belt guard in chrome. This polished and chrome-plated metal guard is formed to fit over the Original Equipment belt guard for easy installation.

60408-09 Fits '09-later Touring models. **\$79.95**

60491-02A Fits '97-'08 Touring models. **\$84.95**

H. REAR SPROCKET BOLT COVER KIT

These chrome-plated covers with internal spring clips hide the Original Equipment sprocket bolts for a clean, custom look. Set of 5 covers.

43876-04 Fits '93-later Softail®, '99-later Touring and '04-later XL models with Original Equipment .4375" hex head sprocket mounting bolts (.625" hex across the flats). **\$38.95**

I. DOME WHEEL CENTER COVER KIT

These chrome-plated hubcaps add style and depth to the Trike's rear wheels. The snap-fit covers have no visible fasteners for a clean, custom look.

40900044 Fits '09-later Trike models. Installation on Original Equipment wheel requires removal of wheel and factory center medallion. **\$39.95**

J. WHEEL CENTER COVER KIT

These chrome-plated hubcaps add style and depth to the Trike's rear wheels. The snap-fit covers have no visible fasteners for a clean, custom look.

83841-09 Fits '09-later Trike models. Installation on Original Equipment wheel requires removal of wheel and factory center medallion. **\$41.95**



G. LOWER BELT GUARD COVER
(60491-02A SHOWN)



H. REAR SPROCKET BOLT COVER KIT



I. DOME WHEEL CENTER COVER KIT



J. WHEEL CENTER COVER KIT

Notice: The prices appearing in this catalog are the manufacturer's suggested retail prices. Actual retail prices may vary.

472 TOURING & TRIKE

Chassis Trim – Rear End

A. FENDER TRIM KIT – CHROME

This Chrome Fender Trim Kit dresses the opening of the wheel well and adds a touch of elegance to the rear of the bike. With no visible fasteners, the trim accentuates the shape and protects the painted edge of the rear fender from minor stone chips. Self-adhesive backing for easy installation.

83812-09 **\$104.95**
Fits '09-later FLHTCUTG and '10-'11 FLHXXX models.



A. FENDER TRIM KIT – CHROME

B. EXHAUST TRIM

This chrome-plated accent piece trims the exhaust openings in the trunk fascia and adds a touch of brightwork to the rear of the bike. Easy to install with no visible fasteners, the formed steel trim features pre-applied high-temp adhesive backing for a clean, uncluttered look.

83843-09 **\$41.95**
Fits '09-later FLHTCUTG and '10-'11 FLHXXX models.



B. EXHAUST TRIM

C. TRUNK GUARD

Unique rear guard wraps around the bodywork to protect your finish from damage. Lightweight steel tubing incorporates high-quality welded joints and is hand-polished and chrome-plated for a brilliant finish. Kit includes all necessary mounting hardware for bolt-on installation.

83825-09B **\$249.95**
Fits '09-later FLHTCUTG and '10-'11 FLHXXX models.

49000069 **\$249.95**
Fits '15-later FLRT models.



C. TRUNK GUARD – TRI GLIDE



C. TRUNK GUARD – FREEWHEELER

Notice: The prices appearing in this catalog are the manufacturer's suggested retail prices. Actual retail prices may vary.

TOURING & TRIKE 473

Chassis Trim – Rear End

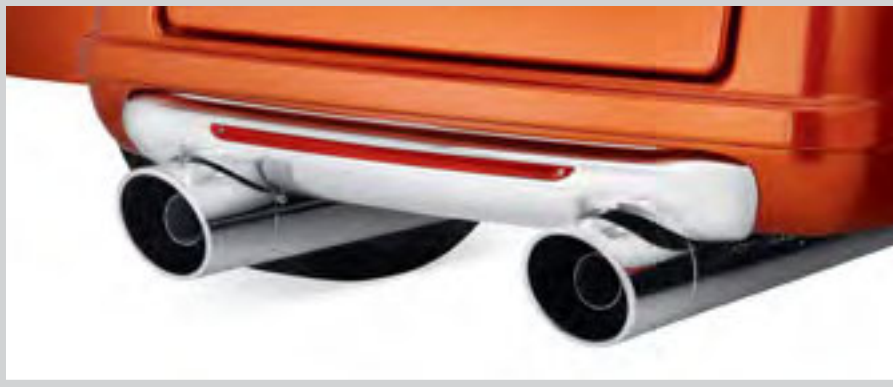

D. ILLUMINATED FASCIA ACCENT TRIM – RED LENS

D. ILLUMINATED FASCIA ACCENT TRIM

Sweeping chrome trim dresses the trunk fascia for a distinctive yet functional look. The inset LED light bar glows as a running lamp when the ignition is on and functions as an auxiliary red lamp when the brakes are applied. Available with smoked or red LED lens to match your customizing direction. Can be installed on models equipped with Trunk Guard.

Fits '14-later Tri Glide® models. Will not fit with Exhaust Trim P/N 83843-09.

68000128	Smoked Lens.	\$249.95
68000129	Red Lens.	\$249.95

Fits '09-'13 Trike models. Will not fit with Exhaust Trim P/N 83843-09.

84028-11	Smoked Lens.	\$239.95
84023-11	Red Lens.	\$249.95



D. ILLUMINATED FASCIA ACCENT TRIM – RED LENS



D. ILLUMINATED FASCIA ACCENT TRIM – SMOKED LENS

E. TRIKE MUD FLAPS – TRI-GLIDE® LOGO

Custom-fit Mud Flaps protect the sides of your Trike's trunk box from spray and road debris and keep the finish clean and free of mud and tar buildup. Custom molded for a perfect fit, these matte black mud flaps feature a raised light gray "Tri-Glide" script logo. Kit includes left and right mud flap, reinforcing brackets and mounting hardware.

59600018		\$59.95
-----------------	--	----------------

Fits '09-later FLHTCUTG and '10-'11 FLHXXX models.

F. STUDED REAR FENDER MUD FLAP

Black mud flap with accenting decorative studs.

59230-88		\$29.95
-----------------	--	----------------

Fits '08-earlier FLHT, FLHS, FLHRC, FLT, FLTR, '86-'90 FLST, '86-'06 FLSTF and '93-'96 FLSTN models. (Does not fit '09-later Touring or models with rear bumper rail.)

G. ROAD KING® CLASSIC REAR FENDER MUD FLAP

Sturdy, black rubber mud flap features the Road King® Classic logo.

59385-98		\$29.95
-----------------	--	----------------

Fits '98-'08 FLHRC and FLTR models.

59386-98		\$29.95
-----------------	--	----------------

Fits '79-'08 FLH, FLHT, FLT, '98-'08 FLTR, '79-'93 FLHS and '94-'08 FLHR. (Does not fit FLHX models.)



E. TRIKE MUD FLAPS – TRI-GLIDE LOGO



E. TRIKE MUD FLAPS – TRI-GLIDE LOGO



F. STUDED REAR FENDER MUD FLAP



G. ROAD KING CLASSIC REAR FENDER MUD FLAP

Notice: The prices appearing in this catalog are the manufacturer's suggested retail prices. Actual retail prices may vary.

474 TOURING & TRIKE

Chassis Trim – Rear End

A. FENDER SUPPORT KIT – GLOSS BLACK

Manufactured from Original Equipment components to ensure superior fit and finish, the gloss black Fender Support Kit replaces the Original Equipment cast and chrome fender support system and continues the dark look to the area between and behind the saddlebags. The ideal finishing touch for your "blacked-out" Touring bike, these covers are the perfect complement to the optional gloss black Passenger Sissy Bars, Luggage Racks, Tour-Pak mounting racks and Docking Hardware Kits. Kit includes gloss black left and right supports and docking hardware slot fillers.

90201206

\$299.95

Fits '14-later Touring models.

B. FENDER STRUT COVERS – GLOSS BLACK

Manufactured from Original Equipment components to ensure superior fit and finish, the gloss black Fender Strut Covers conceal the cast fender struts and continue the dark look to the area behind the saddlebags. The ideal finishing touch for your "blacked-out" Touring bike, these covers are the perfect complement to the optional gloss black Passenger Sissy Bars, Stealth Luggage Rack and Docking Hardware Kits.

47498-09

\$109.95

Fits '09-'13 Touring models (except models equipped with rigid-mounted Tour-Pak® luggage.)

NEW



A. FENDER SUPPORT KIT – GLOSS BLACK

NEW



A. FENDER SUPPORT KIT – GLOSS BLACK

NEW



B. FENDER STRUT COVERS – GLOSS BLACK

Notice: The prices appearing in this catalog are the manufacturer's suggested retail prices. Actual retail prices may vary.

TOURING & TRIKE 475

Chassis Trim – Rear End

C. CVO™ STYLE REAR FENDER SYSTEM

Complete with integrated LED brake lights, turn indicators and tail lights, this custom rear fascia and fender kit keeps the back of your bike clean, classy and simple. Originally featured on CVO™ Touring models, this kit includes everything you need to smoothly blend the shape of the rear fender into the saddlebags and hide the saddlebag mounting structure.

Fits '14-later Touring (except FLHRC and CVO models). Does not fit models equipped with Saddlebag Guard Rails P/N 90200561.

59500246 Domestic (US-only) – Primed. **\$999.95**

59500245 **\$999.95**

International (Australia, Brazil, Canada, Europe, Japan and Mexico) – Primed.

Fits '09-'13 Touring models (except FLHRC). FLHTC and FLHTCU models require separate purchase of Saddlebag Support Kit P/N 90881-09.

59500105BEO Domestic – Primed. **\$999.95**

59500122BEO International – Primed. **\$999.95**



C. CVO STYLE REAR FENDER SYSTEM – WITH CUSTOM VIVID BLACK PAINT ('09-'13 DOMESTIC MODELS)



NEW

C. CVO STYLE REAR FENDER SYSTEM – '14-LATER DOMESTIC MODELS



NEW

C. CVO STYLE REAR FENDER SYSTEM – '14-LATER INTERNATIONAL MODELS



C. CVO STYLE REAR FENDER SYSTEM – '09-'13 DOMESTIC MODELS



C. CVO STYLE REAR FENDER SYSTEM – '09-'13 INTERNATIONAL MODELS

TOURING

FORUM P-H

Notice: The prices appearing in this catalog are the manufacturer's suggested retail prices. Actual retail prices may vary.